

OPERATING MANUAL.

FT-790RII



YAESU MUSEN CO., LTD.
C.P.O. BOX 1500
TOKYO, JAPAN

§1. SPECIFICATIONS	2
1.1 GENERAL	2
1.2 RECEIVER	2
1.3 TRANSMITTER	3
1.4 SUPPLIED ACCESSORIES	4
1.5 OPTIONS	4
§2. CONTROLS & CONNECTORS	6
2.1 FRONT PANEL	6
2.2 REAR PANEL	12
2.3 FBA-6 BATTERY CASE	13
2.4 FL-7025 LINEAR AMPLIFIER	16
§3. INSTALLATION & ACCESSORIES	16
3.1 Portable Station Setup	18
3.2 Mobile Installation	20
3.3 Base Station Installation	22
3.4 FTS-7 Tone Squelch	24
3.4.1 Installation	24
3.4.2 Tone Frequency Selection	25
3.4.3 Tone Level Adjustment	25
§4. OPERATION	26
4.1 Squelch Setup and Tuning	26
4.2 Mode Selection	27
4.3 FM Operation	27
4.4 SSB Operation	28
4.5 cw operation	29
4.6 Memory Operation	30
4.6.1 Alternate VFO	30
4.6.2 CALL Channel (Versions A and X only)	30
4.6.3 Standard Memories	31
4.7 Scanning	32
4.7.1 Stopping the Scanner	33
4.7.2 VFO (all band) scanning:	33
4.7.3 Stored memory channel scanning:	33
4.7.4 Skip Scanning	33
4.7.5 Programmable Memory Scanning (PMS)	34
4.8 Priority Channel Checking	34
4.9 Odd Split Operation	35
4.9.1 Semi-DUPlex operation with Dual VFOs:	35
4.9.2 Semi-DUPlex operation from a memory:	36
4.10 Tone Squelch and Tone Burst	36
4.11 Getting the Most from your Batteries	37
4.12 Memory Backup	RX

FT-790RII ALL MODE
UHF MULTI-PURPOSE TRANSCEIVER



The FT-790RII is a synthesized uhf FM, SSB (USB & LSB) and CW transceiver designed for convenient portable, mobile or base station applications on the 70cm amateur band. Up to 25W of RF power output are available as a mobile or base when used with the FL-7025 clip-on linear amplifier, or 2.5W output as a portable with 9 Ni-Cd batteries (batteries, battery case and/or amplifier are optional in some countries). The lightweight die-cast chassis and simple controls (just three knobs and ten keys) make the FT-790RII ideal for emergencies as well as daily rugged multi-use operation.

Operating conveniences include selectable, mode dependent channel steps, dual vfos and ten memories for frequency, mode, repeater shift and tone status (when optional tone unit is installed). Split frequency semi-duplex operation between the two vfos is provided, as well as one touch reverse for split memories and standard repeater splits. Scanning features include manual and automatic up/down band, memory and selective memory scanning from the tuning knob or supplied microphone, plus priority channel monitoring of any memory while operating on either vfo, and PMS (programmable memory scanning) between memories 1 and 2. An all mode noise blanker and clarifier control are included, and semi break-in QSK is provided for CW.

Please read this manual carefully to gain maximum enjoyment from your FT-790RII.

■ I. SPECIFICATIONS

1.1 GENERAL

Frequency **range:**
per local requirements
see Model **Chart**

Emission types:
FM, SSB (LSB/USB), CW

Channel steps:
FM: 12.5, 25 or 50 kHz
SSB/CW: 25/100/2500 Hz

Antenna:
BNC jack (YHA-44D rubber
flex antenna supplied)

Supply voltage:
8 - 15.8 VDC,
12 15.8 VDC w/FL-7025

Supply current (@12V):
receive: approx 120 mA
transmit: approx 1.5 A
(for 2.5W RF)
w/FL-7025: 8A max

FT-790RII Model Chart

Ver.	Frequency range (MHz)	Rptr Shift (MHz)	Burst (Hz)
A	430 - 450	±5	n/a
B	430 - 440	±7.6	1750
C	430 - 440	±1.6	1750
X	430 - 440	±5	n/a

Case size (WHD):
150 x 57 x 194mm
w/FBA-8 or FL-7025

Weight:
1.2 kg (less FBA-8)
2.1 kg with FL-7025

1.2 RECEIVER

Circuit type:
SSB/CW: Double conversion
FM: Triple conversion

Intermediate Frequencies:
54.5 MHz, 13.9885 MHz,
455 kHz (only FM)

Sensitivity:
SSB/CW: 0.2 µV for 10dB SN
FM: 0.25 µV for 12dB SINAD

Image rejection:
better than 60dB

IF rejection:
better than 70dB

Selectivity (-6/-60dB):
2.4/5.2kHz SSB/CW, 12/25kHz FM

Audio Output:
1W into 8 ohms @10% THD

External Speaker impedance:
4 - 16 ohms

1.3 TRANSMITTER

Input power:
11.5W @13.8V (2.5W output)

Modulation type:
SSB: balanced, filtered
FM: variable reactance

Deviation (FM):
±5 kHz

Carrier suppression:
better than 40dB

Unwanted sideband suppression:
better than 40dB

Spurious response:
-60dB

Tx AF Response:
300 - 2700 Hz (-6dB)

Microphone:
400 ohms, dynamic

Frequency stability (@25°C):
First 30 min.: 300 Hz
After 30 min.: 50 Hz

Specifications may be subject to change in the interest of technological improvements, without obligation to owners.

1.4 SUPPLIED ACCESSORIES

- Ext Spkr and Ext Power Plugs
- * Other items from the following Options list, according to version and local requirements.

1.5 OPTIONS

		<u>Notes</u>
	Shoulder Strap (for portable ops)	
YHA-44D	Rubber Flex Antenna (" " ")	
FBA-8	Battery Case for 9 'C' cells	(2,9,10)
FL-7025	25W Linear Amplifier	(2,3)
FP-700	AC Power Supply for FL-7025	(1)
FP-700S	External AC Power Supply	(1)
FTE-2	1750 Hz Tone Burst Generator	(4,5)
FTS-7	CTCSS Tone Squelch Unit	(5,6)
MH-10E8	Standard Hand Microphone	(7)
MH-10F8	Scanning Speaker/Microphone	(7)
MH-15C8	Scanning DTMF Keypad Microphone	(7)
MF-1A3B	Flexible Boom Microphone	(11)
NC-26B/C/D	Ni-Cd Charger for 117/220/234V	(8,9)
MMB-31	Mobile Mounting Bracket	
csc-19	Soft Case for FT-790RII w/FBA-8	
YH-1	Headset (Mic & Headphone)	(11)
SB-10	PTT Switch Unit for YH-1/MF-1A3B	
SP-55	External Speaker	

Notes:

- (1) Wired for 117, 220 or 234 VAC per local requirements.
- (2) Battery and Linear Amp cannot be connected at the same time.
- (3) Requires 13.8V @8A (FP-700, or automobile battery).
- (4) Installed as standard in B & C versions.
- (5) FTE-2 and FTS-7 cannot be installed concurrently.
- (6) DIP switch programmable.
- (7) One microphone may be supplied as standard.
- (8) Model suffix indicates AC voltage; cannot be altered.
- (9) NC-26 only for use with FBA-8 to charge Ni-Cd batteries.
- (10) Batteries not included.
- (11) Requires SB-10 PTT Switch Unit



S2. CONTROLS & CONNECTORS

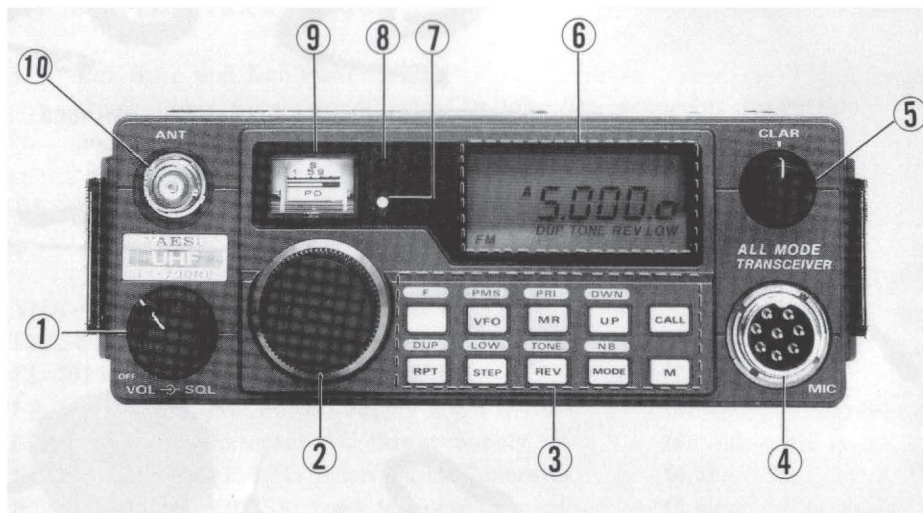

2.1 FRONT PANEL

(1) VOUSQL

The inner VOL control includes the power switch (OFF = counterclockwise), and sets the audio volume of the receiver.

The outer SQL control sets the squelch threshold, above which received signals will activate the audio amplifier and be heard in the speaker. Scanning, if active, stops when the squelch opens, and the green BUSY indicator glows. Turn this control fully counterclockwise to disable the squelch. Normally, to squelch off noise, this control is set clockwise just to the point where noise on a clear channel is silenced.

(2) Main Tuning Knob

This detented knob tunes the operating frequency, or selects the memory channel when in the memory mode. VFO tuning steps are selected independently by mode and the STEP key, as described later. In the memory mode, vacant memory channels are skipped over. The microphone scanning keys function identically to the Main Tuning Knob.

(3) Function Keys

All front panel keys are active only during reception. The primary function of each of the nine gray keys is marked on the key face. Seven of the gray keys have alternate functions, marked on the panel above each, and activated by the yellow key. Throughout this manual, the alternate function of a key will be indicated by enclosing the name of that function in parentheses (), corresponding to the label on the panel above the key.

In certain operating situations, a function will be disabled, in which case pressing the key will not result in an audible beep. Otherwise, all acceptable keystrokes will produce a beep.

F (Alternate Function)

This yellow key has no direct function of its own, but activates the alternate functions of those other keys which have labels marked just above them on the panel. When F key is pressed, the alternate functions are activated for 3 seconds, while 'F' appears to the left of the frequency digits on the display. After this period, if no key is pressed, the 'F' will disappear and the key functions revert to those indicated on the key faces.

RPT (DUP)

This key toggles standard repeater shift* of the transmitting frequency relative to the receiving frequency: either plus or minus the standard shift, or simplex. Multiple presses cause cycling through the three possible settings. When plus or minus shift is selected a '+' or '-' appears near the lower left corner of the display.

The alternate function of this key (DUP) causes split frequency (semi-DUPlex) operation between VFOs A and B, with one VFO determining the transmit frequency and mode, and the other determining receiving frequency and mode. Both VFOs should first be set while receiving. A bar appears beneath the 'DUP' label on the display, and plus or minus repeater shift selections are ignored in semi-duplex operation.

* \pm 1.6, 5 or 7.6 MHz according to transceiver version

VFO (PMS)

The VFO key selects the VFO mode if in the memory mode, and alternates between VFO A and VFO B once in the VFO mode.

The alternate (PMS) function activates 'Programmable Memory Scanning', between the frequencies stored in memory channels 1 and 2. Channel numbers '1' and '2' both appear together at the upper left corner of the display during PMS operation, described in detail later.

STEP (LOW)

The STEP key selects the frequency steps for tuning and scanning. In CW and SSB modes, repeated presses of this key select 25, 100 and 2500 Hz in rotation. In FM, the steps are 12.5, 25 and 50 kHz.

The alternate (LOW) function selects high and low transmitter power. Low power is about 1/5th of high power. When low power is selected, a bar appears beneath the 'LOW' label at the lower right corner of the display.

MR (PRI)

The MR (Memory Recall) key activates the memory mode from the VFO mode. If already in the memory mode, the MR key is used to set a memory channel for selective memory scanning, described in detail later. An 'M' appears at the upper left corner of the display and one or more channel numbers appear along the top edge when in the memory mode.

The alternate (PRI) function activates PRIority channel checking, in which a preselected memory is periodically checked for activity while operating in the VFO mode, as described later.

REV (TONE)

The REVerse key exchanges the transmit and receive frequencies during standard shift repeater operation (+ or - repeat active).

The alternate (TONE) function activates and deactivates the FTS-7 CTCSS tone encoder/decoder, if installed. When active, a bar appears beneath the 'TONE' label on the display. The TONE function is disabled when the Tone Burst Unit (or no tone unit) is installed.

UP (DWN)

In the VFO mode, the UP key increments the operating frequency by 1 MHz in the FM mode, or by 100 kHz in SSB or CW. Holding this key down for more than 2-second causes repeated stepping. In the memory mode, the selected memory channel steps up one each time this key is pressed.

The alternate (DWN) functions causes the same stepping, but in the opposite direction.

MODE (NB)

Pressing the MODE key selects FM, CW, USB and LSB operating modes, in rotation. The selected mode is indicated at the left side of the display.

The alternate (NB) function toggles the noise blanker on and off (all modes). When on, 'NB' appears near the lower left corner of the display.

CALL

In versions without tone burst, this key instantly recalls the Call Channel Memory, regardless of the previous operating status of the transceiver, for simple, quick QSYing. In European versions with the FTE-2 Tone Burst Unit installed, pressing this key causes a 1750 Hz tone to be transmitted (the Call Channel Memory is not available).

M

This Memorize key is used for writing new data into memories, as described in the 'Operation' section.

(4) MIC Jack

This g-pin jack accepts the microphone, and includes control lines for the MH-10F8 Scanning Speaker/Microphone and the MH-15C8 DTMF Microphone. Pinout is shown below.

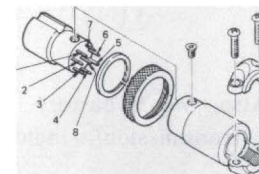

PIN 1 : UP	PIN 5 : NC
PIN 2 : +B	PIN 6 : PTT
PIN 3 : DWN	PIN 7 : GND
PIN 4 : SPKR	PIN 8 : MIC

(5) CLAR Control

This **(CLARifier)** control allows approximately ± 1 kHz adjustment of the receiving frequency, for fine tuning a signal, especially in SSB and CW modes. Remember to set this control at the center detent for proper frequency display during normal tuning or scanning.

(6) Liquid Crystal Display

The following diagram shows all of the display segments. DUP, TONE, REV and LOW are printed on the display filter, and their active status is indicated by a bar beneath the label.

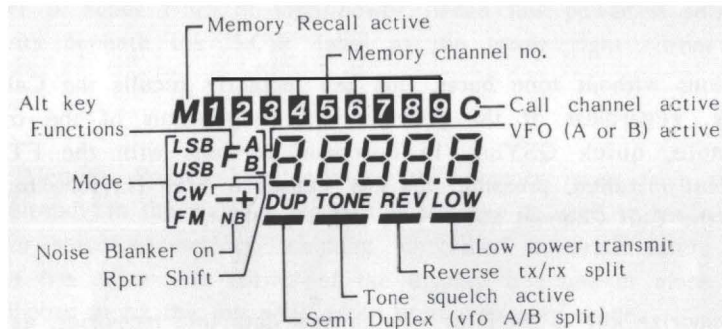

(7) BUSY Indicator

During reception, this green LED glows whenever a signal (or noise) is received that is strong enough to open the squelch. During transmission, this LED flickers with peaks in modulation. Overmodulation causes the LED to glow at full brightness.

(8) ON AIR Indicator

This red LED glows during transmission. Also, when -battery voltage is low, this LED blinks (during reception and transmission), indicating that the battery needs recharging (or replacement).

(9) S/PO Meter

This meter indicates relative signal strength while receiving, and relative power output while transmitting.

(10) ANT Jack

This BNC socket accepts the YHA-44D rubber flex antenna, or other antenna having 50 ohms impedance on the 70cm band. When the FL-7025 Linear Amplifier is connected, this jack is disconnected internally, as the jack on the back of the amplifier is used instead.

(II) EXT SP Jack (Left Side Panel)

This 2-contact mini phone jack accepts a 4- to 16-ohm external speaker, like the Yaesu SP-55. The internal speaker is disabled when a plug is inserted into this jack.

(12) KEY Jack (Left Side Panel)

This 2-contact mini phone jack accepts a CW key for CW transmission. Open circuit voltage is +5V, and closed circuit current is 0.6 mA.

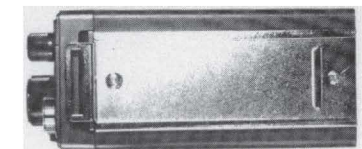
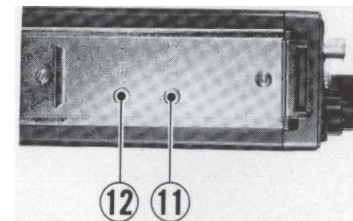

2.2 REAR PANEL

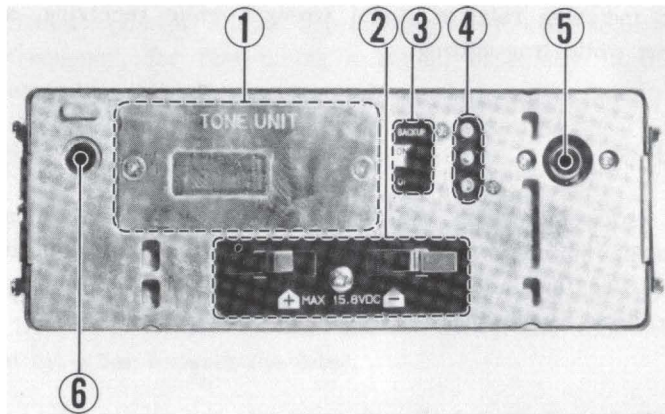

(1) TONE UNIT

The optional FTS-7 mounts behind this subpanel. Tone frequency can be set by the DIP switches on the FTS-7, accessible through the cutout in the subpanel.

(2) Battery Contacts

These two spring contacts accept 8 to 15.8 V DC from the FBA-8 battery case to power the transceiver.

(3) BACKUP Slide Switch

This switch turns the lithium battery memory backup off and on. It is normally left on, except to erase all memories, or for very long term storage.

(4) Accessory Contacts

These three recessed contacts are used by the FL-7025 Linear Amplifier for T/R switching and ALC signals.

(5) RF Jack

This phono jack provides RF excitation to, and receiver input from the FL-7025. Connecting the linear amplifier to this jack disconnects the ANT jack on the front panel of the transceiver.

(6) Lamp Switch Extension

This is a switch extending rod which allows the pilot lamp in the front panel of the transceiver to be activated by the LAMP switch on the rear of the FBA-8 battery case, or by the FL-7025 linear amplifier (which keeps the lamp on all the time during operation).

2.3 FBA-8 BATTERY CASE (Option)

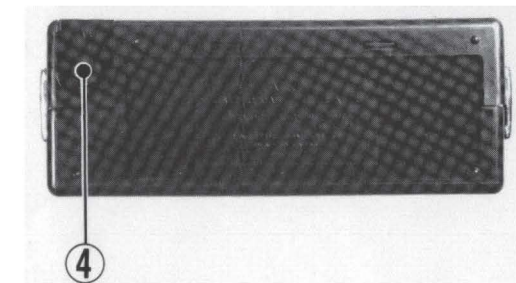
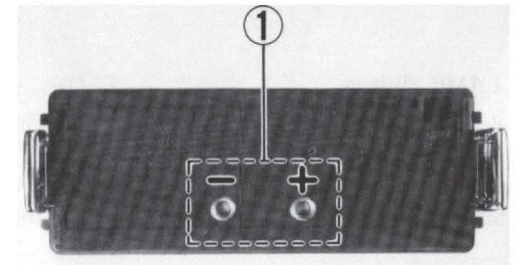
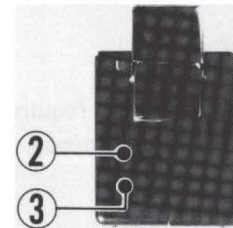

(1) Output Terminals

These terminals provide the power connection to the transceiver (keep them clean).

(2) EXT DC Jack

This coaxial power jack accepts 8 to 15.8 VDC at 1.5 amperes, to power the transceiver from an external DC (negative ground) power source. When the plug is inserted into this jack the batteries in the FBA-6 are disconnected. Use the supplied coaxial plug for making connection to this jack.

(3) CHG Jack

This mini coaxial jack is for connection of the NC-26B (117VAC), NC-26C (220VAC) or NC-26D (234VAC) battery chargers when nine rechargeable Ni-Cd batteries are installed in the FBA-8. We do not recommend connecting any other charger or power source to this jack. Furthermore, no connection should be made to this jack unless nine Ni-Cd batteries are installed.

(4) LAMP Button

Press this button to illuminate the meter and display, when required. If desired, the lamp can be set to stay on whenever the transceiver is switched on by pressing and then turning this button t-turn.

2.4 FL-7025 LINEAR AMPLIFIER (Option)

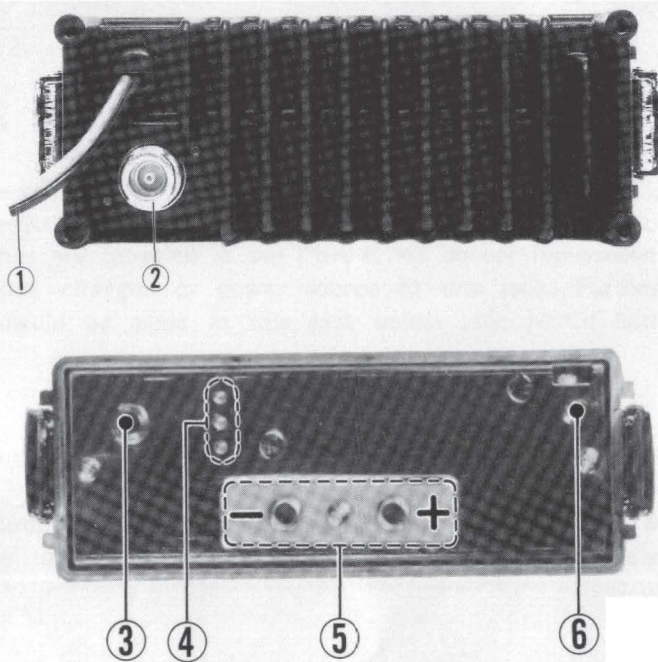

(1) 13.8 VDC Cable Pigtails

This cable accepts 12 to 15.8 VDC at 8A to power the transceiver and amplifier. The RED lead must be connected to positive voltage, and the BLACK lead to negative (ground).

(2) ANT Coaxial Jack

This type-N connector must be connected to a proper antenna (one having 50 ohms impedance at the operating frequency). See the following 'INSTALLATION' Section for details of proper antennas.

(3) RF Jack

This phono plug accepts RF excitation from, and provides receiver input to the transceiver. When this plug is connected to its mating jack on the transceiver the ANT jack on the front panel of the transceiver is disconnected, and the ANT jack on the FL-7025 becomes active instead.

(4) Control Line Pins

These three spring-loaded pins mate with the Accessory Contacts on the transceiver, carrying external ALC from the linear to the transceiver, and T/R relay control and ALC from the transceiver to the linear. Keep the tips of these pins clean.

(5) Supply Output Terminals

These terminals provide the power connection to the transceiver (keep them clean). The contact on the left is ground.

(6) Lamp Actuator Screw

The head of this screw depresses the LAMP switch rod in the transceiver when the linear amplifier is installed, causing the pilot lamp to be on all the time when the transceiver is on. To disable the pilot lamp, remove this screw.

§3. INSTALLATION & ACCESSORIES

The FT-790RII is designed for use as either a portable, mobile or base station, according to which accessories are used with the transceiver. Your FT-790RII will have been supplied with certain accessories for either portable or mobile operation. Contact your Yaesu dealer if you require other options.

3.1 Portable Station Setup

Portable operation requires the FBA-8 Battery Pack, and 9 'C' size batteries, installed as shown below (make certain that the batteries are installed with the correct polarity). If using rechargeable Ni-Cd cells such as the Yaesu NC-1800's, you will also need the NC-26B (117 VAC), NC-26C (220 VAC) or NC-26D (234 VAC) Wall Charger. After installing the cells in the FBA-8, connect the NC-26 to the CHG jack on the FBA-8 and give the batteries a full charge (15 hours) before operating the transceiver for the first time. The FBA-8 may be left connected to the transceiver while charging the batteries, but operating the transceiver while charging is not recommended.

CAUTION: DO NOT ATTEMPT TO CHARGE ALKALINE OR OTHER DRY CELL BATTERIES IN THE FBA-8.

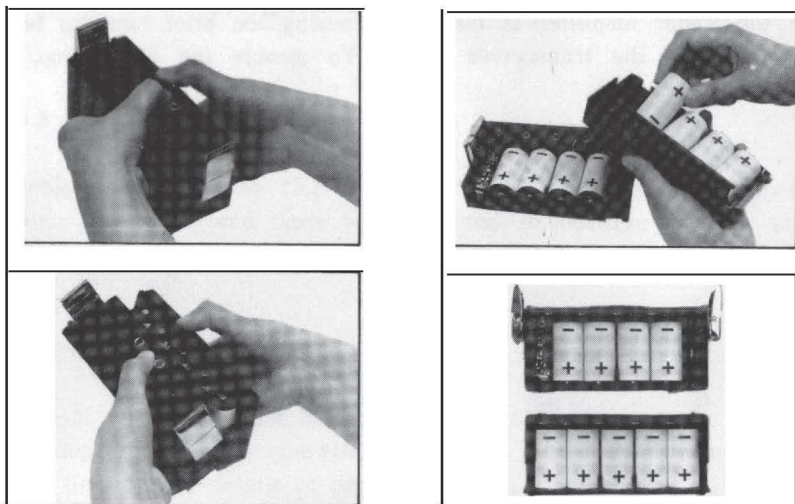

Connect the supplied YHA-44D antenna to the ANT jack on the transceiver: just push the BNC connectors together while turning the plug $\frac{1}{4}$ -turn clockwise. You can use another antenna with the FT-790RII, but make certain that it is designed for the 70-cm band (50-ohm, unbalanced feed). Also, install the shoulder strap in the eyelets on the corners of the transceiver as shown below, and connect the microphone to the MIC jack.

During portable operation, remember that the location of the antenna may have a great affect on signal strength. Weak signals may be improved by moving the transceiver around to obtain the highest S-meter reading during reception (generally as high and in the clear as possible). The MH-10F8 Speaker Microphone or YH-I Headset and SB-IO PTT Switch Unit can be especially convenient when it is necessary to reposition the transceiver.

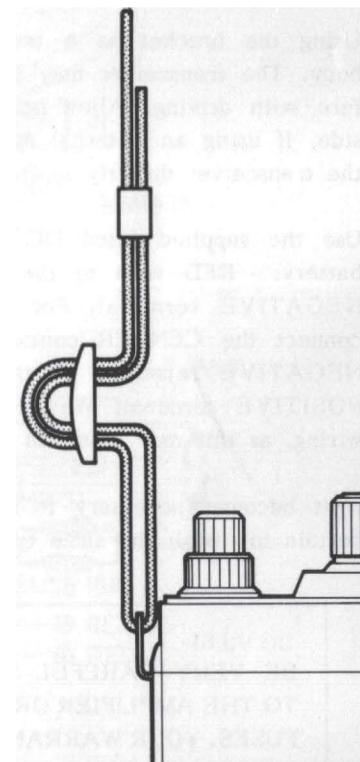
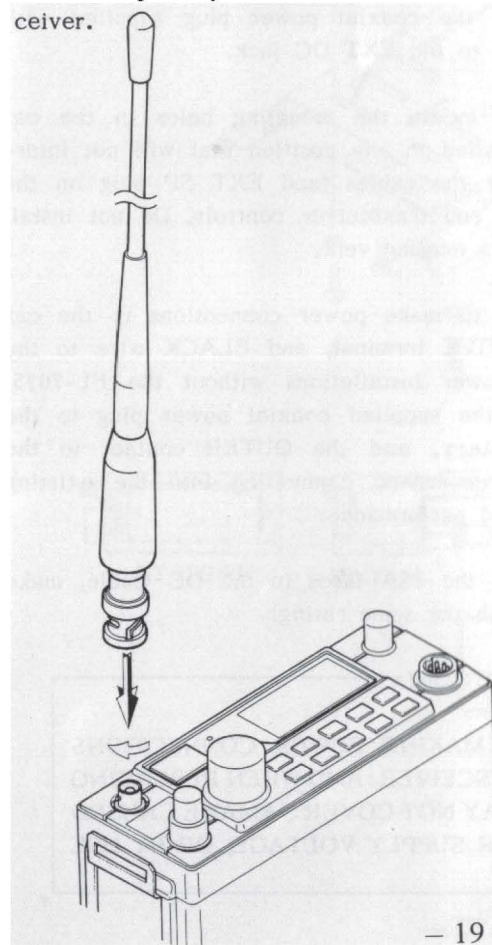

3.2 Mobile Installation

The FL-7025 **25-watt** Linear Amplifier (with DC Cable) and MMB-31 Mobile Bracket **are** available for mobile installations (negative-ground vehicles only!). The FL-7025 may be mounted permanently in the Mobile Bracket, if desired, using four of the supplied bolts (the transceiver can still be slid in and out of the bracket for quick conversion to portable or base operation). When mounting the FL-7025 in the bracket, **remove** the latch clips on either side of the amplifier (two screws each).

The FT-790RII may also be installed as a low power mobile station without the FL-7025, in which case external power from the vehicle battery is supplied to the EXT DC jack on the side of the FBA-8, which must be attached to the transceiver. Use the coaxial power plug supplied with the transceiver to make connections to the EXT DC jack.

Using the bracket as a template, locate the mounting holes in the car body. The transceiver may be installed in any position that will not interfere with driving. Allow space for the cables (and EXT SP plug on the side, if using an external speaker) and transceiver controls. Do not install the transceiver directly in front of a heating vent.

Use the supplied fused DC Cable to make power connections to the car battery: RED wire to the POSITIVE terminal, and BLACK wire to the NEGATIVE terminal. For low power installations without the FL-7025, connect the CENTER contact of the supplied coaxial power plug to the NEGATIVE terminal of the battery, and the OUTER contact to the POSITIVE terminal. We do not recommend connecting into the existing wiring, as this may result in reduced performance.

If it becomes necessary to replace the IOA fuses in the DC Cable, make certain to install the same type, with the same rating.

CAUTION!

BE VERY CAREFUL WHEN MAKING POWER CONNECTIONS TO THE AMPLIFIER OR TRANSCEIVER, AND WHEN REPLACING FUSES. YOUR WARRANTY MAY NOT COVER DAMAGE CAUSED BY REVERSED OR IMPROPER SUPPLY VOLTAGE. OR BY USE OF AN IMPROPER FUSE.

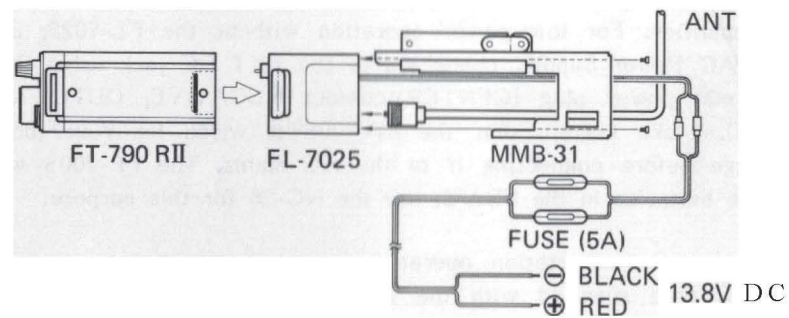
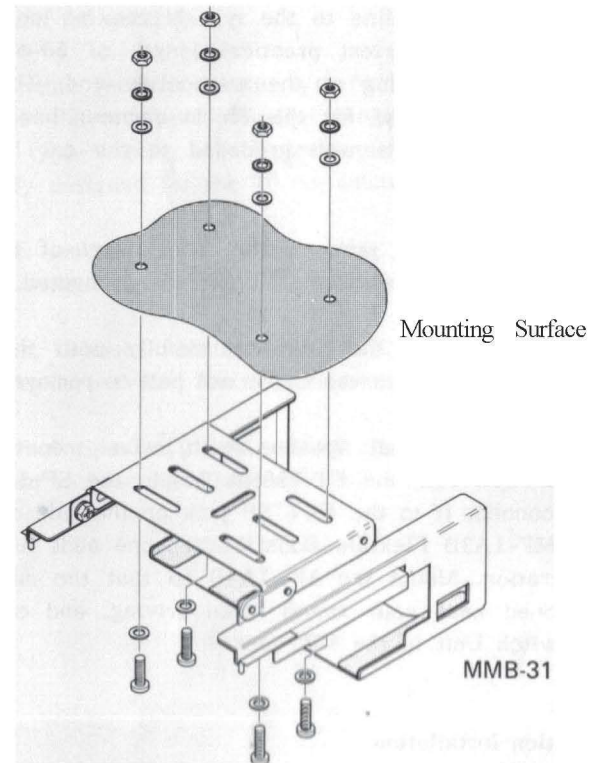

Connect your antenna **feedline** to the type-N coaxial jack on the back of the FL-7025. Use the shortest practical length of **50-ohm** coax for the feedline, with a type-N plug at the transceiver end. The antenna should be one specifically designed for the **70-cm** amateur band. Make sure the antenna mounting bracket is well grounded to the car body at the base of the antenna.

Note: The BNC antenna jack on the front panel of the transceiver is automatically disconnected when the FL-7025 is connected.

Slide the transceiver into the bracket carefully until the small catch at the front corner clicks. Press the catch and pull to remove the transceiver.

The optional SP-55 External Speaker (with swivel mount) is recommended for mobile operation with the FT-790RII. Mount the SP-55 in a convenient location, and connect it to the EXT SP jack on the side of the transceiver. The optional MF-IA3B Flexible Boom Microphone adds further convenience in mobile operation. Mount the **MF-1A3B** so that the microphone element can be positioned near your mouth when driving, and connect it via the **SB-10** PTT Switch Unit to the **MIC** jack.

3.3 Base Station Installation

The FT-790RII may be used as a base station with or without the FL-7025 Linear Amplifier. For low power operation without the FL-7025, use the **FP-700S** AC Power Supply, connected to the EXT DC jack using the supplied coaxial power plug (CENTER contact NEGATIVE, OUTER contact POSITIVE). Make certain that the **FP-700S** is wired for your local AC line voltage before connecting it to the AC mains. The **FP-700S** will not charge the batteries in the FBA-8; use the NC-26 for this purpose.

For high power base station operation with the FL-7025, use the fused (**10A**) DC cable supplied with the Linear Amplifier. We recommend the FP-700 Power Supply, or an equivalent providing 13.8 VDC at **10A** continuously. Connect the RED power lead to the POSITIVE supply terminal, and the BLACK lead to the NEGATIVE terminal.

Do not place the transceiver on top of another heat generating device.

If using the FL-7025, keep the area around the **heatsink** clear, to permit the free flow of air for cooling.

Connect your antenna **feedline** to the type-N coaxial jack on the back of the FL-7025. Use the shortest practical length of **50-ohm** coax for the feedline, with a type-N plug at the transceiver end. The antenna should be one specifically designed for the **70-cm** amateur band.

Note: The BNC antenna jack on the front panel of the transceiver is automatically disconnected when the FL-7025 is connected.

For CW operation, connect your key to the KEY jack on the side of the transceiver. A plug is provided for **this** purpose.

The SP-55 External Speaker, mentioned in the previous section, is also a convenient addition to base **installations**.

3.4 FTS-7 Tone Squelch

The FTS-7 is a DIP-switch programmable subaudible tone generator and decoder that provides tone squelch operation using the operator's choice of 37 standard subaudible (CTCSS) tones, for silent channel monitoring and operation through CTCSS-equipped repeaters. The FTS-7 can be installed only in transceivers in which the FTE-2 Tone Burst Unit is not already installed. Operation is described in 54.10.

3.4.1 Installation

- (1) Remove the battery pack or amplifier, and referring to the photos below, remove the two screws securing the TONE UNIT subpanel on the back of the transceiver. Remove the subpanel.
- (2) Locate the plastic connector inside the tone unit compartment, and mate it with the jack on the FTS-7, using care to ensure proper pin alignment.
- (3) Apply the double-sided adhesive tape (supplied) to the FTS-7, and then attach the FTS-7 in the tone unit compartment as shown.
- (4) Remove the knock-out on the subpanel to permit access to the DIP switches. Then replace the subpanel and its two screws.

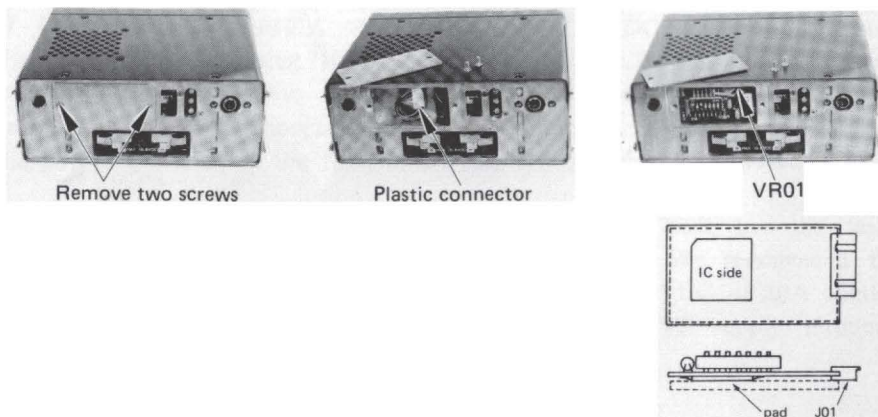

3.4.2 Tone Frequency Selection

With the battery pack or amplifier removed, refer to the DIP Switch Programming Chart below, and set the six switches on the FTS-7 for the desired tone (the switches are accessible through the hole in the Tone Unit subpanel). Note that 'o' in the Chart indicates that the switch should be set to the ON position. Switch number 7 should only be set to the OFF position if tone squelched reception is not to be used while CTCSS transmission is required.

3.4.3 Tone Level Adjustment

The tone output level of the FTS-7 Is preset at the factory for the proper level, and normally requires no readjustment. However, if a particular situation requires a different tone level, this may be adjusted by trimmer potentiometer VR01, shown in the photo on the previous page.

EXAMPLES

FREQ	SWITCH NUMBER *					
	1	2	3	4	5	6
67.0Hz	o	-	-	-	-	-

ON
1 2 3 4 5 6 7 67.0Hz

FREQ	SWITCH NUMBER *					
	1	2	3	4	5	6
77.0Hz	o	o	-	-	-	-

ON
1 2 3 4 5 6 7 77.0Hz

FREQ	SWITCH NUMBER *					
	1	2	3	4	5	6
88.5Hz	o	-	o	-	-	-

ON
1 2 3 4 5 6 7 88.5Hz

↑
ON = Enc/Dec
OFF = Encoder only

FTS-7 DIP SWITCH PROGRAMMING

FREQ	SWITCH NUMBER *						FREQ	SWITCH NUMBER *					
	1	2	3	4	5	6		1	2	3	4	5	6
67.0Hz	o	-	-	-	-	-	136.5Hz	-	-	-	-	-	-
71.9	-	o	-	-	-	-	141.3	o	-	-	-	-	o
74.4	-	-	o	-	-	-	146.2	-	o	-	-	-	o
77.0	o	o	-	-	-	o	151.4	o	o	-	-	-	o
79.7	-	o	o	-	-	o	156.7	-	-	o	-	-	o
82.5	-	-	o	-	-	o	162.2	o	-	o	-	-	o
85.4	-	-	-	o	-	o	167.9	-	o	o	-	-	o
88.5	o	-	o	-	-	o	173.8	o	o	o	-	-	o
91.5	-	o	o	o	-	o	179.9	-	-	-	o	-	o
94.8	-	o	o	-	-	o	186.2	o	-	-	o	-	o
100.0	o	o	o	-	-	-	192.8	-	o	-	o	-	o
103.5	-	-	-	o	-	-	203.5	o	o	-	o	-	o
107.2	o	-	-	-	-	-	210.7	-	-	o	o	-	o
110.9	-	o	-	-	-	-	218.1	o	-	o	o	-	o
114.8	o	o	-	o	-	-	225.7	-	o	o	o	-	o
118.8	-	-	o	-	-	-	233.6	o	o	o	o	-	o
123.0	o	-	-	o	-	-	241.8	-	-	-	-	-	o
127.3	-	o	o	o	-	-	250.3	o	-	-	-	-	o
131.8	o	o	o	o	-	-							

* DIP SW o = ON DIP SW NO ⊙ ON = TONE SQUELCH
OFF = ENCODER ONLY

§4. OPERATION

Before switching on the transceiver, check to ensure that the antenna, microphone and battery pack (or external power source) are properly connected. Preset the SQL control fully counterclockwise, and the CLARIFIER to its center detent.

4.1 Squelch Setup and Tuning

Turn on the transceiver by rotating the VOL control clockwise out of the click-stop. The green BUSY indicator should light, while the display shows the last three, four or five digits of your receiving frequency (beginning with 1's of MHz and a decimal point). Advance the VOL control for comfortable volume on a signal or noise.

Press the VFO key to select VFO operation, and use the tuning knob to tune to a clear frequency (where only background noise is heard). Turn the SQL control clockwise just to the point where the green BUSY lamp goes off and stays off (and the noise is silenced).

If you have a scanning microphone, try tuning with the microphone UP-/DWN buttons, press either button momentarily to single step, or hold it down for manual scanning. To stop, release it and then press it again (or the PTT switch) momentarily to halt. When the PTT switch is used to halt scanning, no transmission occurs.

For large frequency changes, such as for moving from one part of the band to another, 'giant' steps are available via the UP (DOWN) key on the front panel. Just press this key once to take one giant step up, or press the F key and then this key to take one giant step down. Hold this key for more than a half-second for multiple giant steps (and just release it to stop). Giant steps are 1 MHz in FM, and 100 kHz in other modes; except at the band edges, where lesser digits are rounded to the nearest giant step.

4.2 Mode Selection

Press the MODE key while observing the display of operating mode at the left side of the display. Each time this key is pressed the mode will change, in this order: FM - CW - USB - LSB and back to FM. The selected mode will be retained when power is switched off.

4.3 FM Operation

Press the MODE key until 'FM' is displayed at the bottom left. In addition to the 1 MHz giant steps mentioned above, you have a choice of three different tuning steps in the FM mode: 12.5, 25 or 50 kHz. The frequency digits displayed indicate which tuning steps are currently selected: four digits plus a small zero or (full-size) '5' when 12.5 kHz steps are selected, just four digits when 25 kHz steps are selected, and just 3 digits when 50 kHz steps are selected. Press the STEP key to change tuning steps (and watch the display, as partial steps are truncated when switching to coarser settings).

MODE/STEP DISPLAYS

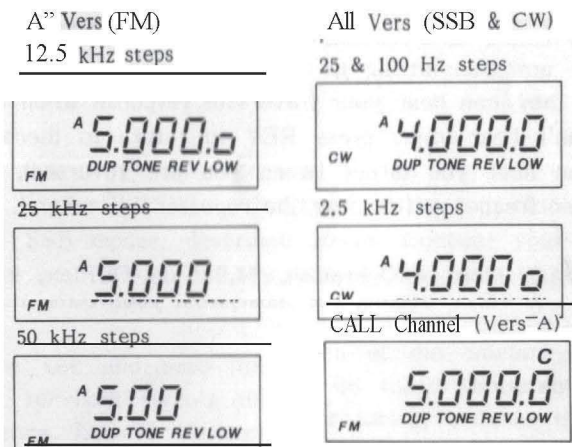

Press the RPT key three times while watching just to the left of the 'DUP' label on the display: you should see '+' and then '-' appear, indicating plus and minus standard transmit repeater shift (1.6, 5 or 7.6 MHz, according to version) from the displayed receiving frequency. When neither is displayed, you are set for simplex operation.

Now tune to the desired operating frequency and press the RPT key as necessary. If on a repeater, you can first check to make sure your transmit frequency will be correct before actually transmitting; just press the REV key to reverse your transmit and receive frequencies, and then press it again to return to normal.

Close the PTT switch on the microphone to transmit. The display will indicate your actual transmitting frequency while the PTT switch is held. If out of band, 'Err' is displayed, indicating that your repeater shift is incorrect (no transmission occurs). When you speak into the microphone, occasionally check the green BUSY indicator LED: if you are speaking too loudly (possibly causing distortion) the indicator will be lighting brightly on voice peaks. Speak at a volume that causes the indicator to just occasionally light dimly.

The CALL button in versions B and C automatically keys the transmitter and sends a 1750 Hz burst tone when pressed. Use this key to activate repeaters that require the burst tone.

If someone wants to chat with you on the repeater, press the REV key while they are transmitting to see if you can hear them on the input. If so, see if they can hear your (reversed) response when they finish talking. If they don't hear your, press REV to return to the repeater. However, if they can hear you direct (when you are reversed), ask them to QSY to a simplex frequency (to clear the repeater for others).

See also §4.6. Memory Operation, §4.9 Semi-DUPlex, §4.10 Tone Squelch and Burst, and §4.11 Getting the Most from your Batteries.

4.4 SSB Operation

Press the MODE key until either 'USB' or 'LSB' (depending on which is used in your area: usually USB) is displayed at the bottom left. In addition to the 100 kHz giant steps mentioned previously, you have a choice of three different tuning steps in the SSB modes: 25 Hz, 100 Hz or 2.5 kHz. In all cases, five digits of frequency are displayed, with resolution to 100 Hz. When 25 Hz steps are selected, the display will change only once for every four tuning steps, while when 2.5 kHz steps are selected, the last digit will be half-size when it is a zero (press the STEP key and

try it: watch the display, as partial steps are truncated when switching to coarser settings). Use the large steps when tuning around in search of a signal, and the small steps for tuning one in when you hear it. The 100 Hz steps are convenient for scanning, described later. When not scanning, it may be helpful to set the SQL control fully counterclockwise if you want to catch very weak signals.

If you hear pulse type noise, press the F and MODE (NB) key to activate the noise blanker, indicated by 'NB' on the display at the lower left. Press these keys again to turn the blanker off when not needed.

To transmit, close the microphone PTT switch and speak at normal conversational level into the microphone. As with FM, if you are talking too loud the green BUSY indicator will be glowing brightly on voice peaks. If the station you are talking with comes back slightly off frequency, use the CLAR control to fine tune your receiving frequency. When finished, remember to return the CLAR to the center detent.

See also 54.6 Memory Operation, §4.7 Scanning, and 84.11 Getting the Most from your Batteries.

4.5 CW Operation

Press the MODE key until 'CW' is displayed at the left. Tuning steps are the same as for SSB modes, described above. Connect your key to the KEY jack on the left side of the transceiver. Key up voltage is 5V, and key down current 0.6 mA.

Briefly close the key and note the pitch of the sidetone. This is the same pitch that received signals should be tuned for in order to zero beat their frequency. Use 25 Hz steps for tuning, and use the CLARifier control to zero beat. To transmit, just close the key. The FT-790RII provides semi break-in operation; returning to receive one-half second after you stop keying.

Sidetone volume is adjustable (together with keypad beep volume) by VR4002 on the PLL Unit on the bottom of the chassis.

4.6 Memory Operation

The FT-790RII has nine standard memories plus the two vfos, which serve as special function memories. Versions A and X also have a calling channel memory, which is recalled by the CALL key. Each stores frequency and mode, and all but the vfos also store +/- RPT setting, and tone call data (described later). The vfo memories (and the CALL memory for versions A and X) are described first:

4.6.1 Alternate VFO

VFO B simply duplicates the VFO functions that have already been described, without affecting the other VFO (VFO A). Notice that, during VFO operation, a small 'A' or 'B' appears just to the left of the frequency digits on the display. To switch from one VFO to another, just press the VFO key repeatedly. In the following paragraphs, when 'VFO' is referred to, it means either VFO A or B.

To copy one VFO to the other:

- (1) Press the VFO key to select the source VFO.
- (2) Press the M key followed immediately by the VFO key.

4.6.2 CALL Channel (Versions A and X only)

This special memory allows instant recall of a prestored frequency (and mode and +/-RPT setting) at any time (except when transmitting, of course). Store your main operating frequency or emergency channel here for instant recall.

To store the CALL channel:

- (1) Set the VFO to the desired frequency and mode.
- (2) Press the RPT key if this is a repeater channel.
- (3) Press the M key and then the CALL key.

To recall the CALL channel just press CALL. Press CALL again to return to your original channel.

4.6.3 Standard Memories

Data to be stored in the standard memories must originate in the VFO. Once stored, it is possible to change some settings temporarily and even permanently, or to erase the memory altogether. Be careful though, as writing data to a memory always overwrites any previous data stored there.

To store data in a memory:

- (1) Set the VFO for operation as desired in the memory.
- (2) Press the M key once, followed immediately by the UP key to select the desired channel number for storage.
- (3) Press the M key again to store.

Step 1 includes setting mode and repeater shift (if needed), as well as frequency: all will be stored in the memory. At step 2, when M is pressed, an 'M' will blink at the upper left corner of the display, together with one channel number (blinking). Other non-blinking channel numbers may also appear: these already have data stored in them. The one channel number that is blinking is the one selected for storage. To select another channel for storage, press the UP key on the front panel (not the microphone) to step up one channel number (or F (DWN) to step down one channel number). In this case you must press and release the key repeatedly to move more than one channel. This selection process may require some practice, as you are allowed only three seconds maximum between keystrokes. If the blinking 'M' disappears before you reach step 3, start again. The time limit provides some security against accidental overwriting of memories.

Once you have successfully reached step 3, operation will return to the original VFO, but now this same data will be available in the memory.

To recall a memory:

- (1) Press the MR key.
- (2) Turn knob or use Mic UP/DWN keys to select memories.

During memory recall operation, an 'M' appears at the upper left, with the recalled memory number to the right of it. You are free to change

the mode or repeater shift of a recalled memory: such changes will be temporary unless you press the M key twice to store the new settings.

Other memories that have been previously stored can be recalled by the tuning knob, or by the UP/DWN keys on the microphone.

If you have stored a memory but do not want to have it recalled every time you check the other memories, you can 'hide' it.

To delete (hide) a memory:

- (1) Recall the memory channel.
- (2) Press M and then MR.

The display data will disappear, and the memory will appear empty.

To recall a deleted (hidden) memory:

- (1) Use the front panel UF' key to select the memory channel.
- (2) Press M and then MR.

Be careful not to overwrite hidden channels when storing new data, as there is no way to distinguish between hidden channels and those that are truly empty.

To return to the VFO from the memory mode, press the VFO key.

4.7 Scanning

Three types of scanning are possible with the FT-790RII: VFO, memory channel or PMS (Programmable Memory Scanning). In each case, scanning is started by the UP/DWN keys on the microphone. Scanning pauses automatically for five seconds when a carrier is detected by the receiver and then resumes again automatically. If the carrier drops while the scanner is paused, scanning will resume after one second (unless another carrier appears). The decimal on the frequency display blinks while the scanner is paused on a channel.

4.7.1 Stopping the Scanner

Momentarily press the UP/DWN keys or PTT switch on the microphone to stop the scanner. Note that the normal function of these keys is suspended during scanning, so pressing them will only stop the scanner (no transmission or further scanning will occur). To resume scanning, or to transmit, first release the key or switch, and then press it again.

4.7.2 VFO (all band) scanning:

- (1) Select VFO frequency and mode.
- (2) Press mic UP or DWN key for 1-second.
- (3) Press STEP or MODE to change steps or mode.
- (4) Press mic UP/DWN or PTT, or VFO key to stop.

4.7.3 Stored memory channel scanning:

- (1) Press MR if not already In Memory mode.
- (2) Press mic UP or DWN key for 1-second.
- (3) Press mic UP/DWN or PTT, or MR key to stop.

Only the stored memories are scanned.

4.7.4 Skip Scanning

It is also possible to skip certain memory channels only when scanning. Such channels can still be selected manually via the tuning knob or mic UP/DWN keys, but will be ignored by the scanner. These channels are distinguished by a blinking channel number at top of the display (vs solid numbers for scannable memory channels).

Skip a channel during memory scanning:

- (1) Press MR if not already in Memory mode.
- (2) Select channel number to skip (top of display).
- (3) Press MR: channel number should start blinking.
- (4) Press mic UP or DWN key for ½-sec to start scanning.

To reinstate a channel for scanning, just repeat the above steps, pressing MR when the (blinking) channel number is selected; it will stop blinking.

4.7.5 Programmable Memory Scanning (PMS)

PMS allows you to scan just a selected portion of the band, between the (lower) frequency stored in memory 1 and the (higher) frequency stored in channel 2. When this PMS mode is active, channel numbers 1 and 2 are both displayed together at the top left, and scanning as well as manual tuning are limited within the selected range.

PMS (limited band) scanning:

- (1) Store low edge frequency from VFO into channel 1.
- (2) Store high edge frequency from VFO into channel 2.
- (3) Press F and then VFO (PMS): Ch nos. 1 & 2 both displayed.
- (4) Press mic UP or DWN key for $\frac{1}{2}$ -sec to start scanning.
- (5) Press STEP or MODE to change either.
- (6) Press mic buttons to stop scanning, and then VFO, M or CALL to escape the PMS band limits.

4.8 Priority Channel Checking

While operating on a VFO, you can monitor for activity on a memory channel. While the Priority function is active, the priority memory channel number will be displayed. When a signal is found on that channel, operation will shift to it and priority channel checking will stop.

Priority operation:

- (1) Store priority frequency & mode from VFO to memory.
- (2) Select this memory channel in the memory mode.
- (3) Press F and then MR(PRI).
- (4) Operate on VFO as desired.
(The priority channel number is displayed)
- (5) To cancel, press VFO, MR or CALL.

Step (1) can be skipped if the priority channel is already stored in memory, and step (2) can be skipped if it is already selected (or was selected last when in memory mode).

If priority channel activity interrupts a QSO you are having on the VFO frequency, just press V to return to the VFO, and then MR to return to the priority channel.

4.9 Odd Split Operation

The semi-DUPlex function of the FT-790RII allows split (transmit/receive: frequency operation with shifts other than the standard repeater shift provided by the RPT key. This is done by storing the transmit frequency in one VFO and the receiving frequency in the other VFO, and then activating the DUP function.

4.9.1 Semi-DUPlex operation with Dual VFOs:

- (1) Set one VFO to the transmit frequency and mode.
- (2) Press the VFO key to select the other VFO.
- (3) Set this VFO to the receive frequency and mode.
- (4) Press F and then RPT(DUP).
(A bar appears under the 'DUP' label on display)

To cancel DUP operation, press F and then RPT(DUP) again.

Note that the mode set in steps 1 and 3 should normally be set the same; if different, you will end up working cross-mode. While the DUP function is active, you can reverse VFOs by pressing the VFO key, and you can recall (and operate) on memories by pressing MR. When the VFOs are used for DUP operation, you can change the transmit frequency using the main knob or microphone UP/DWN keys while pressing the PTT switch. You can also store the odd split in memories 3 through 9, or the CALL channel.

4.9.2 Semi-DUPlex operation from a memory:

- (1) Perform all steps in Section 4.9.1.
- (2) Press M, and then UP on the front panel to select the desired memory channel (or CALL in versions A and X) and then M again.
- (3) Press MR to recall the memory.

Memory storage is the same as for regular VFO data, except that memories 1 and 2 cannot be used. In step 2, you have just three seconds between keystrokes. Also, when operating from memories, you cannot change the channel frequencies (they must be re-entered from the VFOs). It is possible, however, to cancel DUP operation or change modes of the memories, and to reverse split transmit and receive frequencies with the REV key.

4.10 Tone Squelch and Tone Burst

The FTS-7 Tone Squelch Unit is available as an option for versions A and X. Tone frequency and encode/decode or decode-only status are selected by DIP switches on the FTS-7 through the TONE UNIT subpanel when the battery or amplifier is removed. See 63.4 for FTS-7 installation and DIP switch programming.

To activate the tone squelch, press F and then REV(TONE). 'TONE' will be displayed at the upper right corner of the display. To deactivate the tone squelch, just repeat the same keystrokes. If you wish the tone squelch to be always active on a particular memory, set the tone on when storing the memory.

The 1750 Hz burst tone function (in B and C versions) is provided by the FTE-2 Tone Burst Unit, installed at the factory. As mentioned previously, the burst tone can be activated in the FM mode by just pressing the CALL key (the transmitter is keyed automatically when this key is pressed). The tone is transmitted for as long as the CALL key is held. Note that the CALL key cannot be used to recall a memory when the tone burst feature is installed.

4.11 Getting the Most from your Batteries

When operating the FT-790RII with the FBA-8 battery pack, you may wish to prolong the charge life of the batteries as much as possible in some situations. The actual charge life will vary widely according to how much time is spent transmitting, and (to a lesser degree), which mode you use and how you monitor for calls. When the batteries become weak, the red ON AIR indicator will begin to blink. Replace the batteries right away (or recharge them if they are rechargeable NI-Cd types).

The LOW power feature of the FT-790RII can greatly extend battery life, by up to two or three times, and it is a good idea to get into the habit of always using this feature, switching only to high power when necessary. To set LOW power transmission: Press F and then (LOW) (a bar appears under the 'LOW' label on the display).

Press F and then (LOW) again to return to high power.

If you find that you always need higher power, consider using a larger antenna (with more gain) instead of the high power setting. This has the same effect as higher power, without shortening battery life.

You can further increase battery life for non-repeater communications by using an SSB mode as much as possible, instead of FM. SSB signals generally have greater range than FM because of narrower bandwidth, and thus allow low power to be used in situations where high power would be required in FM. Also, SSB requires less current drain by the transmitter, since no carrier needs to be transmitted.

In many cases, where FM repeater communications are used, simplex SSB would serve just as well, saving considerable battery drain. Note, however, that SSB will not work through an FM repeater, and both stations in communication must be equipped for SSB operation.

Further savings of battery life can be obtained during reception by using the lowest practical audio volume, and by squelching off the receiver when monitoring. Using headphones can allow practical operation at low volume even in noisy surroundings.

The last trick is perhaps the simplest of all, but one easily overlooked: turn the power off when not using the transceiver. The memory backup system will retain all settings when power is off, so there is no need to keep it on unless you are making or expecting a call.

Summarizing, For maximum battery life:

- (1) Keep transmissions short.
- (2) Use LOW power whenever possible.
- (3) Use a high gain antenna, if available.
- (4) Use SSB (instead of FM) when you can.
- (5) Keep the audio volume down, or use headphones.
- (6) Squelch the receiver when monitoring.
- (7) Turn the set off when not monitoring or talking.

4.12 Memory Backup

If the transceiver is exposed to high voltage electrostatic discharge the microprocessor can become confused and disoriented, in which situation the transceiver may fail to operate normally. Before seeking repairs, you can try resetting the microprocessor by switching the BACKUP switch on the rear panel off for a minute, and then back on (you must remove the FBA-8 or FL-7025 to access the BACKUP switch).

See also 84.6 Memory Operation, 54.7 Scanning, and §4.11 Getting the Most from your Batteries.