

CARATTERISTICHE TECNICHE

Tensione di ingresso
Tensione di uscita

SPECIFICATIONS

Input supply voltage
Output voltage

220V Vca 50 Hz
13.8 Vdc

K45	K75	K105	K205	K305
3A - 5A	6A - 8A	10A - 12A	20A - 22A	30A - 32A

SCHEMAELETTRICO • ELECTRICDIAGRAM

General Circuit Diagram (*)

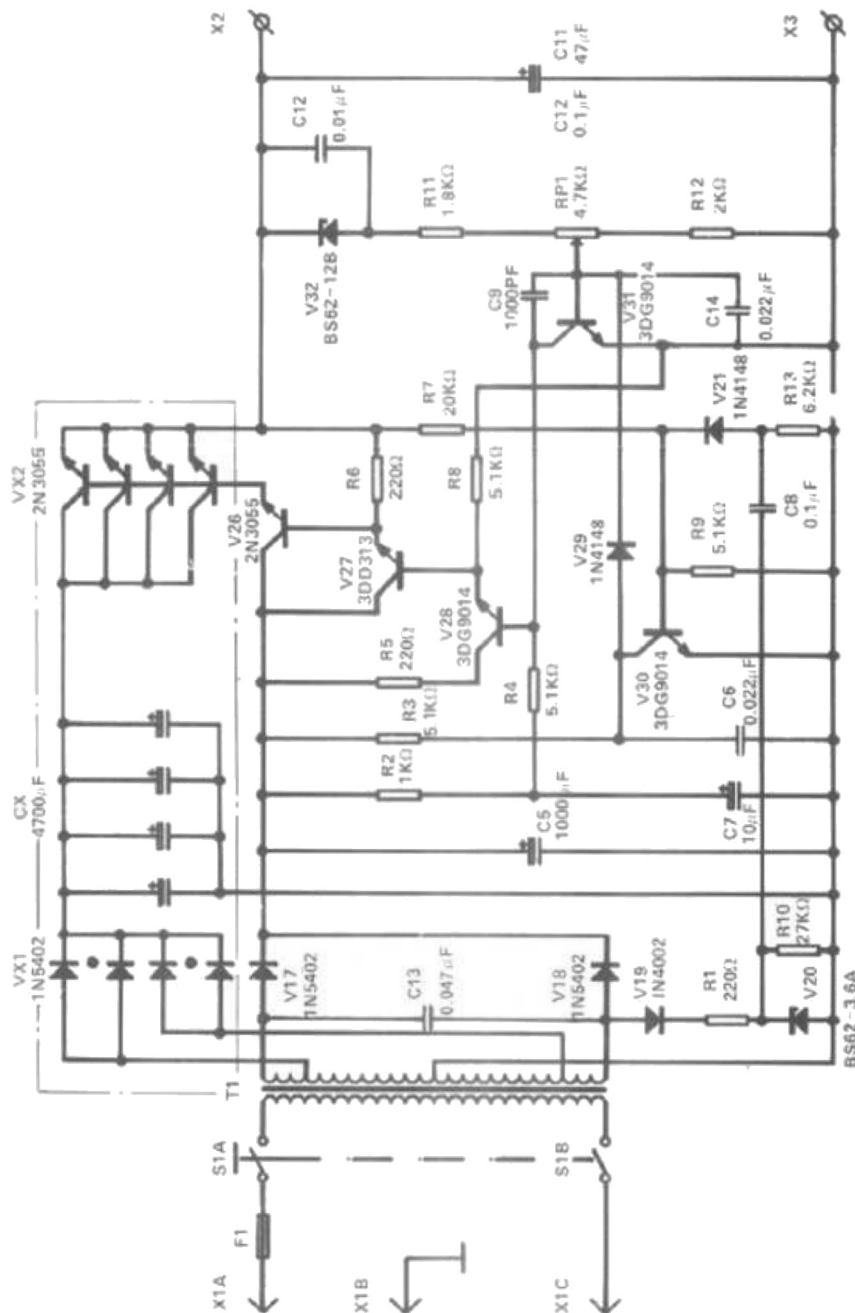

(*)Note: This is the standard circuit for 20A output. For different model, the number of diodes, capacitors and transistors inside the frame line will be increased or decreased.