

MML 144/100-S MML 144/100-HS 144 MHz 100 WATT LINEAR AMPLIFIERS

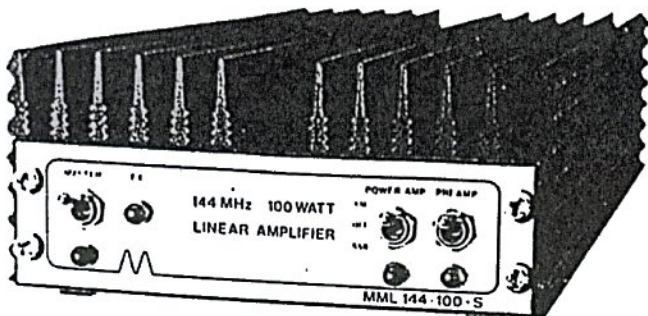

FEATURES

- 100 WATTS OUTPUT POWER.
- SUITABLE FOR 10 OR 25 WATT TRANSCEIVERS.
- LINEAR ALL-MODE OPERATION.
- STRAIGHT THROUGH OPERATION WHEN TURNED OFF.
- ULTRA-LOW NOISE RECEIVE PREAMPLIFIER — FRONT PANEL SELECTABLE.
- EQUIPPED WITH RF VOX AND MANUAL OVERRIDE.
- LED STATUS LIGHTS FOR POWER, TRANSMIT AND PREAMP ON.

SPECIFICATION

Linear Amplifier

Power output	: 100 watts \pm 1 dB
Power input	: 10 watts (MML144/100-S) 25 watts (MML144/100-HS)
Frequency bandwidth	: 144-146 MHz at -1 dB
Power requirements	: 13.8 V DC at 12 Amps
Quiescent current	: 1 Amp (with zero drive)

Receive Preamp

Overall gain	: 12 dB typical
Overall noise figure	: Better than 1.5 dB
Frequency bandwidth	: 144-146 MHz at -1.5 dB
Receive current	: 130mA

General

RF connector	: SO239
Size	: 265x117x54mm
Weight	: 1.5 Kg

DESCRIPTION

These 144 MHz solid state linear amplifiers MML144/100-S and MML144/100-HS, are intended for use with any existing 144 MHz transceivers with output powers of 10 and 25 watts respectively. When used in conjunction with the appropriate drive sources, the amplifiers will provide an output power of 100 watts.

Several front panel mounted switches controlling the internal switching circuitry, allow the unit to be left in circuit at all times. The linear power amplifier and the ultra low-noise receive preamplifier, which are incorporated into the unit, can both be independently switched in and out of circuit. In this way, all four operational combinations are possible.

By means of an internal RF vox circuit the linear will automatically switch on to transmit when 144 MHz drive is applied to the input socket. It is possible to override this facility by the connection of an earth to the phono socket located on the rear panel. This connection is compatible with all current transceiver PTT lines. The RF vox circuit is suitable for both SSB and FM modes.

The inclusion of the latest state of the art power transistor (rated at 80W dissipation) guarantees highly reliable and ultra-linear performance, thus making the unit ideal for all modes of operation (SSB, FM, AM, CW and SSTV). The PA transistor is thermally tracked against temperature variation and operational temperature rise.

The receive preamplifier uses one of the latest dual gate FETs in a noise-matched configuration. This technique, together with careful optimisation of overall gain, makes the preamplifier ideal for use ahead of any popular 2 metre transceiver. The sensitivity of current 2 metre transceivers is such that a preamplifier gain of 12 dB is sufficient to ensure an excellent overall system noise figure.

A preamplifier with gain in excess of this figure will prove unduly detrimental to the strong signal-handling performance of the transceiver.

All circuitry is constructed on high quality glass-fibre printed circuit board and protection is included against reverse polarity. The unit is housed in a highly durable extruded aluminium enclosure. RF input and output sockets are located on the rear panel together with the power lead and phono socket. The unit is supplied with all necessary connectors.



MICROWAVE MODULES LTD.

Brookfield Drive, Aintree, Liverpool L9 7AN, England.
Telephone: 051-523 4011. Telex: 628608 MICRO G.

4) Delay Time for RF Vox (SSB Mode only)

Your amplifier includes an internal adjustment to allow the user to change the time constant in the RF Vox circuitry, to suit individual preference. As supplied, the amplifier has been factory-set on production, with a delay time (transmit mode to receive mode) of about one half second. The adjustment as described below allows the delay time to be adjusted continually over the range zero to 2.5 seconds.

When switched to SSB, the amplifier may be adjusted to increase or decrease the delay time as follows :

- a) Remove the four screws holding the front panel in place, ensuring that AT NO TIME do any of the switch connections come into contact with the heatsink.
- b) Gently ease forward the front panel away from the heatsink, and slide forward the amplifier base-plate.
- c) Place the unit as shown in the diagram below, and locate the preset potentiometer marked 'V' on the diagram.
- d) Rotating this potentiometer will vary the delay according to preference.
- e) Replace the baseplate, and relocate the front panel taking great care not to trap any wires.

IMPORTANT: Take extreme care not to adjust any other variable components as this will invalidate your guarantee.

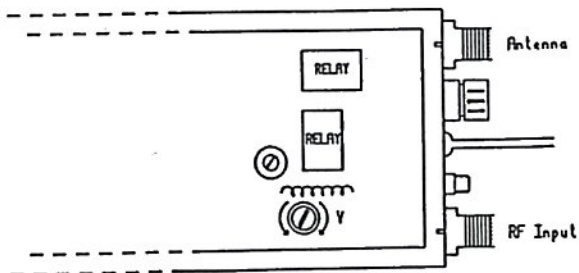

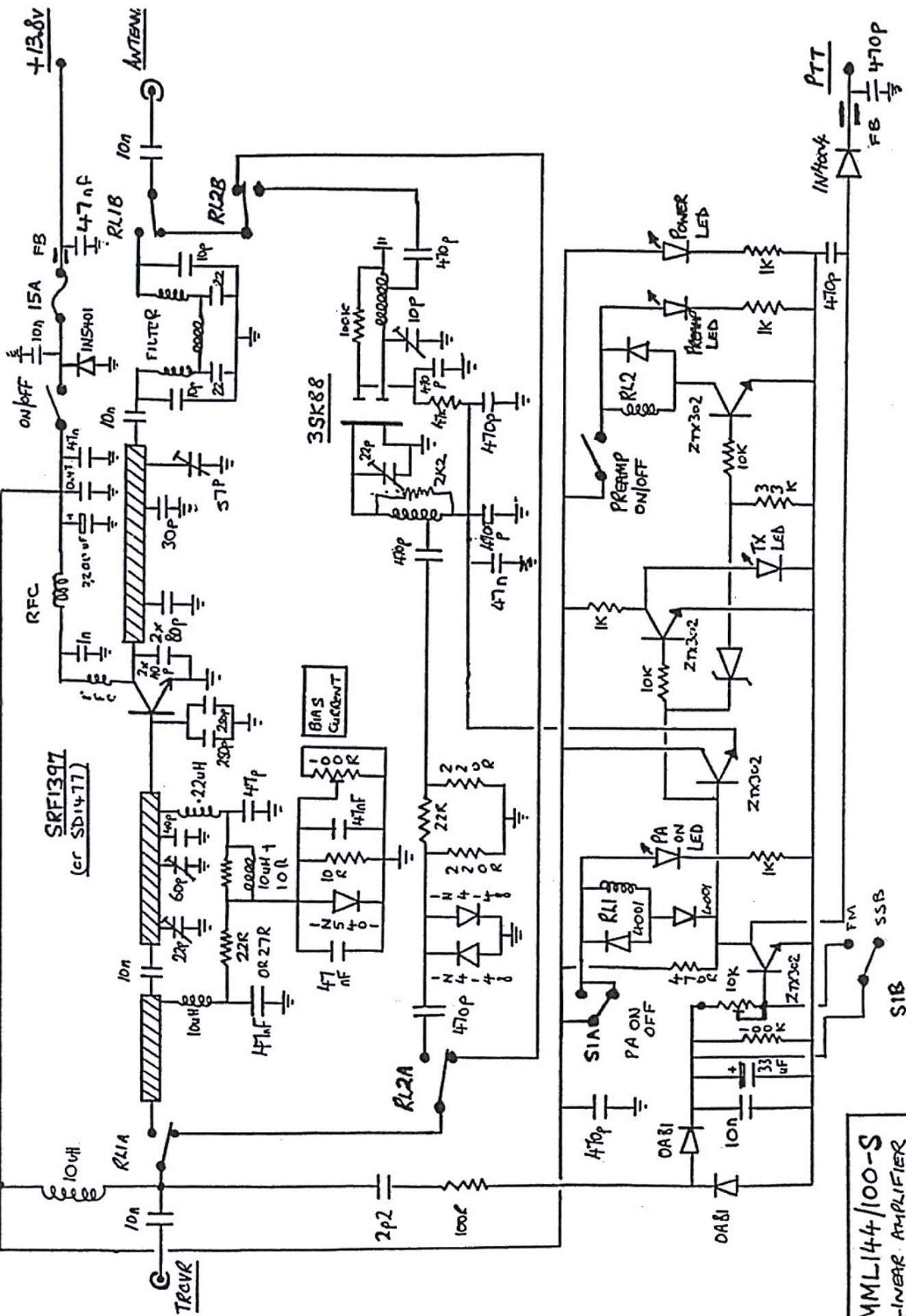

MML144/100-S
 LINEAR AMPLIFIER
 & RECEIVER PREAMP