

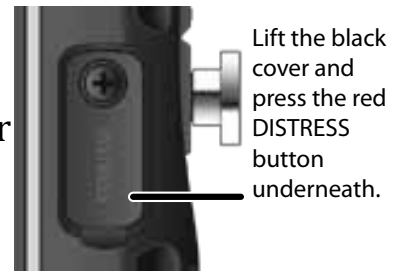

## MAKING A DISTRESS CALL

Lift the black cover. Press and hold the ***DISTRESS*** button for three seconds. Your radio transmits your boat's location every few minutes until you receive a response.



🚫 **NOTE: If the radio displays *Enter User MMSI*, cancel the automatic distress call and make a normal voice distress call.**

### Making a Voice Distress Call

**Speak slowly - clearly - calmly.**

For future reference, write your boat's name & call sign here:

1. Make sure your radio is on.
2. On the microphone, press the ***16/9-TRI*** button to switch to Channel 16 (156.8 MHz). (If the corner of the display does not show 16, press the ***16/9-TRI*** button again until it does.)
3. Press the ***PUSH TO TALK*** button on the microphone and say: **"MAYDAY -- MAYDAY -- MAYDAY."**
4. Say **"THIS IS {name of your boat (three times) and call sign/boat registration number (once)."**
5. Repeat **"MAYDAY {name of your boat}"** once.
6. Tell where you are: (what navigational aids or landmarks are near, or read the latitude and longitude from your GPS).
7. State the nature of your distress (e.g. are you sinking, medical emergency, man overboard, on fire, adrift, etc. ).
8. State the type of assistance you need (medical, towing, pumps, etc.).
9. Give number of persons aboard and conditions of any injured persons.
10. Estimate present seaworthiness of your ship (e.g. how immediate is the danger due to flooding or fire or proximity to shore).
11. Briefly describe your ship, giving ship name (e.g. "Blue Duck is 32 foot cabin cruiser, white hull, blue deck house").
12. Say: **"I WILL BE LISTENING ON CHANNEL 16."**  
**OVER.**

---

14. Release the ***PUSH TO TALK*** button and listen.

If you do not get an answer after 20 seconds, repeat your call

# FAIRE UN APPEL DE DÉTRESSE

Pour toute référence ultérieure, transcrivez ci-dessous le nom et l'indicatif d'appel de votre bateau:

--

**Parlez lentement – clairement – calmement.**

1. Vérifiez si votre radio est en marche.
2. Appuyez sur la touche **16/9-TRI** du microphone afin de commuter au canal 16 (156,8 MHz). (Si le canal 16 n'apparaît pas à l'affichage, appuyez de nouveau sur la touche **16/9-TRI** jusqu'à ce qu'il soit affiché.)
3. Appuyez sur le bouton de microphone **Push to Talk** et dites: "**MAYDAY -- MAYDAY -- MAYDAY**".
4. Donnez l'identité de votre navire en disant : "**ICI** {nom de votre bateau (trois fois) ou indicatif d'appel et le numéro d'identification de votre bateau (une fois)}".
5. Dites "**MAYDAY** {nom ou indicatif d'appel de votre bateau} une fois".
6. Donnez votre position : (quels sont les points de repère ou aides à la navigation près de vous ou lisez les coordonnées de longitude et de latitude apparaissant sur votre dispositif GPS).
7. Révélez la nature de votre détresse (par exemple, nous sommes en train de couler, urgence médicale, un homme à la mer, un incendie, nous sommes à la dérive, etc.
8. Révélez la nature de l'aide désirée (médicale, remorquage, essence, etc.)
9. Donnez le nombre de personnes à bord et les conditions des blessés, s'il y en a.
10. Donnez la condition de navigabilité actuelle de votre navire, tel que le degré de l'urgence par rapport une inondation, et une incendie.
11. Donnez une brève description de votre navire en donnant le nom du bateau (par exemple, "Blue Duck est un yacht de croisière de 32 pieds, avec une coque blanche et un rouffle bleu.).

---

12. Dites : "**JE VAIS ÉCOUTER SUR LE CANAL 16**".
13. Terminez le message en disant "**ICI** {nom ou indicatif d'appel

# Table of Contents

<b>Introduction.....</b>	<b>E-1</b>	Setting Key Lock.....	E-22
Features .....	E-1	Setting WX Alert Mode..	E-22
<b>Getting Started.....</b>	<b>E-4</b>	Setting FIPS Codes .....	E-22
What's included .....	E-4	Adjusting the Lamp.....	E-22
Parts of the MHS135 .....	E-5	Adjust the LCD Contrast	E-23
Front view .....	E-5	Setting the Temperature	
Back view.....	E-5	Measure .....	E-23
Charger.....	E-7	Turning the Key Beep On and	
Reading the display .....	E-7	Off.....	E-23
Display icons and what they		Operating the Radio .....	E-24
mean .....	E-7	Changing the Channel ..	E-24
<b>How It Works.....</b>	<b>E-8</b>	Making a Transmission..	E-24
Menus.....	E-8	Changing the transmission	
Normal Menu .....	E-9	level.....	E-24
Call Menu.....	E-10	<b>Digital Selective Calling Features</b>	
GPS Menu .....	E-11	<b>E-25</b>	
Operation Modes.....	E-11	What is DSC? .....	E-25
Normal.....	E-13	Advanced DSC features ...	E-26
Scan.....	E-14	MMSI Numbers.....	E-27
Weather .....	E-17	Entering MMSI numbers	E-27
<b>Setting Up the Hardware....</b>	<b>E-18</b>	Entering Your User MMSI	
Attaching the Antenna .....	E-18	Number .....	E-28
Installing the Battery .....	E-18	Entering a group MMSI	
Using Alkaline Batteries .....	E-18	number .....	E-29
Mounting the Charger .....	E-20	Entering an individual MMSI	
Charging the Battery.....	E-20	number .....	E-29
Important notes on charging		Using the Directory .....	E-30
the battery .....	E-20	Making DSC Calls .....	E-31
<b>Setting Up Your Radio.....</b>	<b>E-21</b>	Calling a single station	
Turning It On .....	E-21	(Individual Call) .....	E-33
Setting It Up.....	E-21	Calling a particular group of	
Changing the Volume ..	E-21	stations (Group Call) ....	E-33
Setting the Squelch Level	E-21	Calling all stations (All-Ships	
Setting the UIC Channel Mode		Call).....	E-34
(USA/CAN/INT).....	E-22	Making an automatic distress call	
		E-34	
		Canceling an automatic	
		distress call .....	E-35

---

Receiving a DSC call.....	E-35	switching .....	E-44
Receive log .....	E-36	<b>GPS Features .....</b>	<b>E-45</b>
Returning a call from the		GPS Operation Overview ..	E-45
Receive Log .....	E-38	Favorites Menu .....	E-45
Test Calls .....	E-38	Goto Menu .....	E-45
Making Test Calls (Test)	E-38	Selecting a Goto Favorite	E-46
Receiving Test Call Setup	E-40	Add Menu.....	E-46
Acknowledging Test Call		GPS Setup Menu .....	E-46
Receipt .....	E-40	Using the Strobe LED .....	E-47
Position Request and Reply	E-41	Renaming Channels .....	E-48
Requesting another station's		<b>Maintenance and</b>	
position (POS Request)	E-41	<b>Troubleshooting.....</b>	<b>E-49</b>
Receiving a position request		Common Questions .....	E-49
(Position Reply) .....	E-42	<b>Specifications .....</b>	<b>E-51</b>
Enabling automatic position		Channels and Frequencies	
reply .....	E-42	(MHz) .....	E-52
Position Send .....	E-43	<b>Regulations and Safety</b>	
Putting the radio into		<b>Warnings.....</b>	<b>E-59</b>
standby .....	E-43		
Disabling automatic channel			

## INTRODUCTION

### Features

Your radio provides the following key features:

- **Submersible design**  
Complies with floating JIS8/IPX8 water-resistant standards, which means the radio can be submerged in 1.5 meters of water for 30 minutes without damage.

#### **Notes:**

The radio will only meet this rating if fully assembled and all rubber seals and bungs are well maintained and correctly fitted. This means that the speaker microphone bung is inserted, and the battery pack (or case) and antenna are attached and securely fastened.

After your radio is submerged in water, the sound might be distorted. This is because there is still water remaining in and around the speaker and microphone. Just shake the radio to clear excess water, and the sound should return to normal.

If your radio is exposed to salt water, clean it thoroughly with fresh water and dry it before turning it on.

The charger is not waterproof.

- **Memory scan mode**  
Lets you save channels to memory and monitor them in quick succession.
- **Transmitter power level select**  
Lets you boost the transmitter power from 1 W to 2.5 or 6 W for added transmission distance.
- Battery level display and low battery alert.
- **Dual and Triple Watch operation**  
These different watch modes let you monitor up to two Coast Guard Distress/Hailing channels and one weather channel along with one regular marine channel.
- All marine VHF channels for the U.S., Canada, and international waters
- **National Oceanic and Atmospheric Administration (NOAA) Weather Channel watch**  
Sounds a warning tone when a hazard alert is issued.
- **SOS Strobe**  
A high intensity strobe LED can be set to blink an SOS pattern or to be steady on.
- **Temperature**  
Lets you display temperature in Fahrenheit or Celsius.
- **DSC**  
Lets you call other stations or groups using their unique identification code.
- **GPS**  
Gives you the ability to save your current position as well

as manually enter other positions. You can save positions into a directory to return to them as desired.

## GETTING STARTED

### What's included



MHS135 Radio



Antenna



Charger

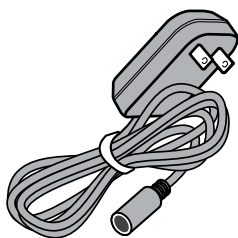

AC Adapter

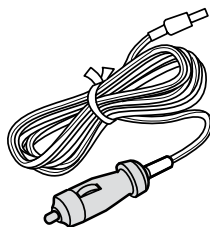

DC Adapter

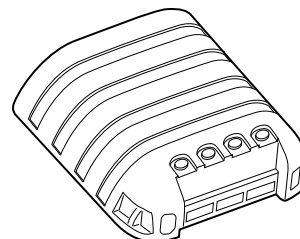

Lithium Ion  
Battery

Alkaline Battery  
Case  
(batteries not  
included)

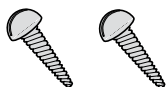
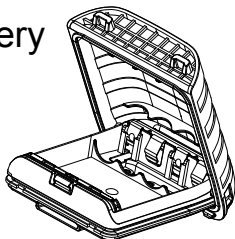

Mounting Hardware

Belt Clip

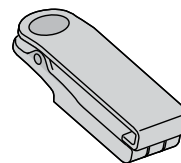

Wrist Strap

If any pieces are missing or damaged, contact Uniden Customer Service (see back cover for contact information). For information on available accessories, visit [www.uniden.com](http://www.uniden.com).

# Parts of the MHS135

## Front view



## Back view

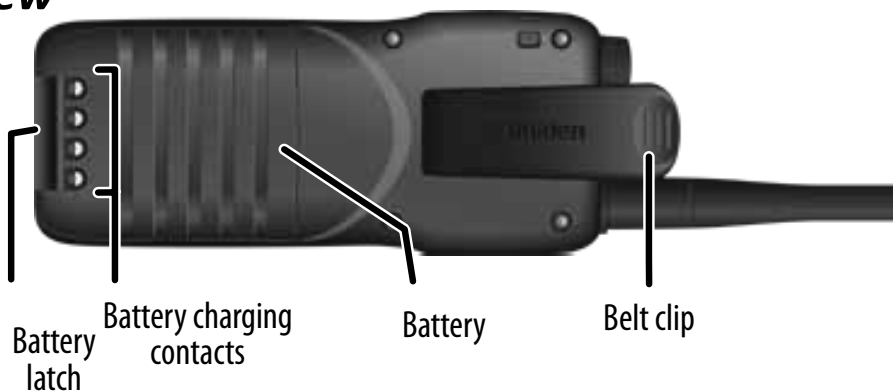



<b>Button</b>	<b>Press to...</b>	<b>Press and hold to...</b>
<b><i>Push -to-Talk</i></b>		Transmit on a current TX power
<b><i>Boost</i></b>	Boost TX to 6 W..	
<b><i>16/9-Tri</i></b>	1st press: Go to CH 16. 2nd press: Go to CH 9. 3rd press: Go back to the starting channel.	Turn Triple Watch on and off.
<b><i>WX/SOS</i></b>	<ul style="list-style-type: none"> <li>- Turn Weather mode on and off.</li> <li>- Move cursor to the left while in Menu mode.</li> <li>- Change Strobe light mode.</li> </ul>	Turn Strobe SOS light on and off.
<b><i>MENU/CALL</i></b>	Access the radio menu.	Access DSC call menu.
<b><i>ENTER H/M/L/</i></b>	<ul style="list-style-type: none"> <li>- Select menu items.</li> <li>- Return to normal Marine mode when Marine channel list is displayed.</li> </ul>	Change the TX power between Low (1W), MID (2.5W), and 6W.
<b><i>CLR/SCAN</i></b>	Exit menu screens.	Enter or exit Scan mode.
<b><i>GPS/MEM</i></b>	Enter or exit the GPS menu.	Store or delete the current channel into memory.
<b><i>VOL-SQ</i></b>	Enter or exit Volume Setting mode.	Enter or exit Squelch Setting mode.
<b><i>Channel Up</i></b>	Move up one channel at a time.	Move quickly up the channels.
<b><i>Channel Down</i></b>	Move down one channel at a time.	Move quickly down the channels.
<b><i>Power</i></b>		Turn MHS135 on and off.
<b><i>Distress</i></b>		Sends out emergency signal.

## Charger

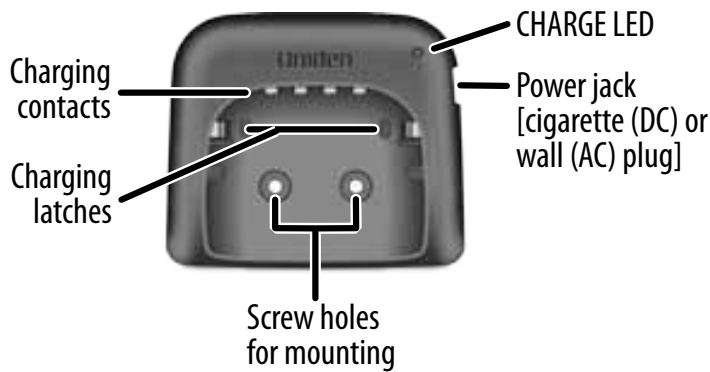

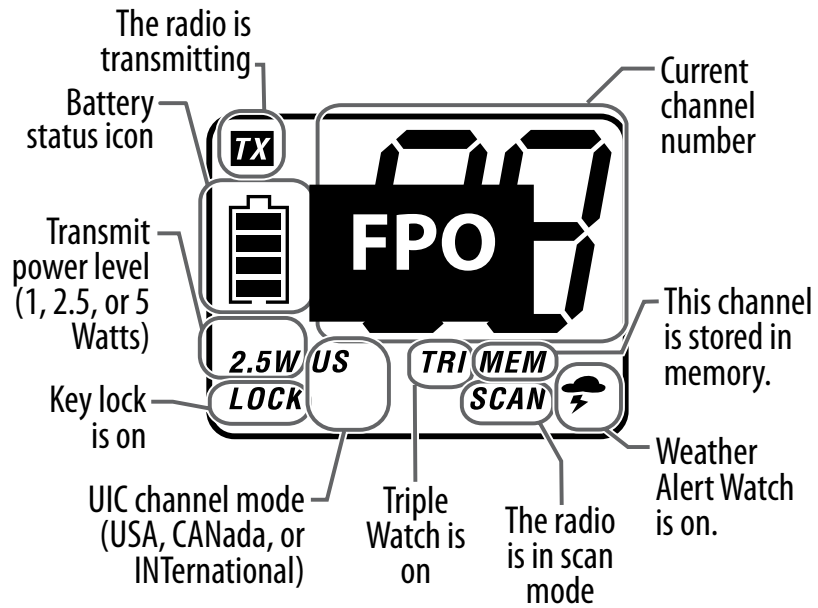

## Reading the display

The LCD display shows different information depending on what you are doing. This sample screen shows some of this information. The table below shows all the possible icons and what they mean.

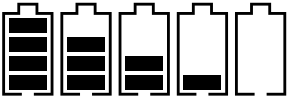

## Display icons and what they mean

Icon	What it means
<b>TX</b>	You are currently transmitting.
<b>1W, 2.5W, or 5W</b>	The transmitter power is set to LOW (1W), MID (2.5W), or 6W.
<b>LOCK</b>	The keys are locked.
<b>US, CAN, or INT</b>	The radio is set to use US channels, CANadian channels, or INTernational channels.
<b>TRI or DUAL</b>	TRIple Watch or DUAL Watch is turned on.

Icon	What it means
<b>MEM</b>	The current channel is saved in memory.
<b>SCAN</b>	The radio is in Scan mode.
<b>WX</b>	The radio is in Weather mode.
	Weather Alert Watch is turned on.
	The battery is fully charged, mostly charged, half charged, mostly empty, or completely empty.
	You have unread messages in the Receive Log.

## HOW IT WORKS

The **MENU/CALL** key accesses menus that let you set up how you want your radio to operate. Your radio has four operation modes. These modes are described on page \_\_\_\_\_

### Menus

You can set up the radio's physical displays and operation modes (*Normal* menu), how you want to receive and send various types of calls (*Call* menu), and GPS operations (*GPS* menu).

Press **MENU/CALL** to display the *Normal* menu. Press and hold **MENU/CALL** to display the *Call* menu. Press **GPS/MEM** to display the *GPS* menu.

Do This...	To Display...
Press <b>Menu/Call</b>	<i>Normal</i> menu - Display mode - Setup - System

Do This...	To Display...
Press and hold <b>MENU/</b> <b>CALL</b>	<i>Call</i> menu <ul style="list-style-type: none"> <li>- Individual</li> <li>- Group</li> <li>- All Ships</li> <li>- POS Request</li> <li>- Position Send</li> <li>- Test</li> <li>- Standby</li> <li>- Receive Log</li> <li>- DSC Setup</li> </ul>
Press <b>GPS/MEM</b>	<i>GPS</i> menu <ul style="list-style-type: none"> <li>- Favorite</li> <li>- GPS Setup</li> </ul>

### ***Normal Menu***

The submenus of the *Normal* menu lets the user set up the radio. The submenus are:

Submenu	What it does
Display	Selects a display mode for the radio. The options are: <ul style="list-style-type: none"> <li>- Marine</li> <li>- Position</li> <li>- Compass</li> <li>- Favorite</li> <li>- Temperature</li> <li>- GPS Status</li> </ul>

Submenu	What it does
Setup	Expands radio setup options: <ul style="list-style-type: none"> <li>- USA/CAN/INT</li> <li>- Dual/TriWatch</li> <li>- LED</li> <li>- Key Lock</li> <li>- WX Alert</li> <li>- FIPS Codes</li> <li>- Channel Name</li> <li>- DSC Watch</li> </ul>
System	Sets up the radio systems: <ul style="list-style-type: none"> <li>- Lamp Adjust</li> <li>- Contrast/RVS</li> <li>- Temperature</li> <li>- Key Beep</li> </ul>

### **Call Menu**

The submenus of the Call menu set the technical requirements for DSC function operations. The menus are:

Submenu	What it does
Individual	Sends an individual call to an individual station.
Group	Sends a call to a group.
All Ships	Sends <i>URGENCY</i> or <i>SAFETY</i> message to all ships.
POS Request	Requests the position of an individual vessel.
Position Send	Transmits your position to a vessel that was programmed into the DIRECTORY.
Test	Sends a test call
Standby	Places the radio in an unattended mode.

Submenu	What it does
Receive Log	Displays a list of all received calls to the radio. The MHS135DSC stores log data for 10 distress calls and 50 other calls.
DSC Setup	Allows the user to set up Digital Selective Calling (DSC) service.

### **GPS Menu**

The GPS menu lets you save and name sets of GPS coordinates so you can return to that location again. You can recall the saved GPS coordinates, too.

Submenu	What it does
Favorite	Adds (saves) the current GPS position as well as recalls that position to sail back to it.
GPS Setup	Lets you determine the following GPS settings: <ul style="list-style-type: none"> <li>- Sog Unit</li> <li>- GPS Module</li> <li>- NMEA Output</li> <li>- Compass</li> <li>- Unit Power</li> <li>- Power Save</li> <li>- Time Adjust</li> <li>- Daylight Save</li> </ul>

### **Operation Modes**

Your radio has three main operation modes: Normal, Scan, and Weather.

Mode	What it does	Use it when you want to...	To turn it on/off
Normal	Monitors a single marine channel and lets you talk on that channel.	Monitor a channel or talk to another radio.	(default mode)
Scan	Monitors all the channels you save into memory.	Check a small group of regularly-used channels for traffic.	Press and hold <b>CLR/SCAN</b> for 2 seconds.
Weather	Monitors the selected NOAA weather channel.	Hear the current or forecasted weather.	Press <b>WX/SOS</b>

In addition to the three operation modes, your radio provides four different *watch modes* which you can activate during any operation mode. In the watch modes, the radio briefly checks for activity on a specific channel, then returns to its previous operation.

Watch mode	What it does	To turn it on/off
Weather Alert Watch	Checks the last-used weather channel for hazard alerts every few seconds.	Press and hold <b>WX/SOS</b> for 2 seconds.
Dual Watch	Checks emergency channel 16 for activity every few seconds.	Select <i>Dual or Triple Watch</i> at <i>Setup</i> menu, and press and hold <b>16/9-Tri</b> for 2 seconds.
Triple Watch	Checks emergency channels 16 and 9 for activity every few seconds.	Select <i>Dual or Triple Watch</i> at <i>Setup</i> menu, and press and hold <b>16/9-Tri</b> for 2 seconds.
DSC Watch	Checks the DSC channel every 2 seconds for messages from other ships.	Turn <i>DSC Watch</i> on or off from the <i>Setup/DSC Watch</i> menu.

 **Note: Private boats must monitor channel 16 whenever they are underway. Water-going vessels should have either Triple Watch or Dual Watch on at all times.**

## Normal

- To transmit, remove the radio from the charger, then press and hold **Push to Talk**. Release the button when you are finished talking.
- For the best sound quality, hold the microphone about two inches from your mouth while you're talking.
- Press **Channel Up** to move up one channel at a time. Press and hold the button to scroll quickly up the channels.
- Press **Channel Down** to move down one channel at a time. Press and hold the button to scroll quickly down the channels.
- To change the transmit power, press and hold **ENTER H/M/L**. The transmit power cycles through LOW (1W), MID (2.5W), and 6W, then back to LOW again. Press **BOOST** on the left side of the radio to boost the transmit power to 6W (Lithium Ion battery) or to 2.5W (alkaline batteries).

🔇 **If you are using alkaline batteries, 6W is not available.**

## Normal mode with Weather Alert Watch

If you activate Weather Alert Watch while operating in normal mode, the radio

checks the most recently used weather channel every few seconds. If it detects a weather or other hazard alert, it will switch to that weather channel. (If you are actively transmitting, the radio waits until you finish your transmission before checking the weather channel.)





### *Normal mode with Triple Watch or Dual Watch*

If you activate Triple Watch while operating in normal mode, the radio checks channels 16 and 9 every few seconds; with Dual Watch turned on, the radio only checks channel 16. The radio will not check channels 16 or 9 while you are actively transmitting; it waits until your transmission is finished and then checks the channels.

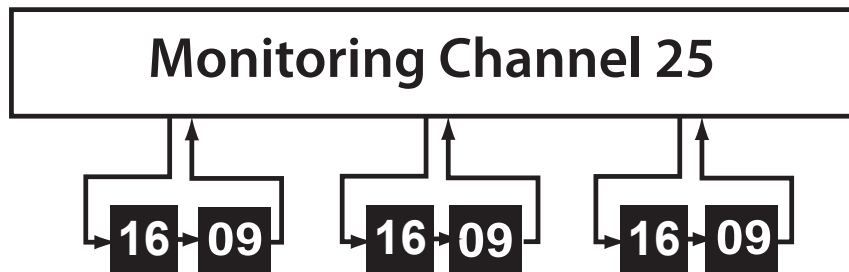

Every few seconds, the radio checks channels 16 & 9.

**Triple Watch on**

### *Normal mode with DSC Watch*

If you activate DSC Watch while operating in Normal mode, the radio checks channel 70 every few seconds.

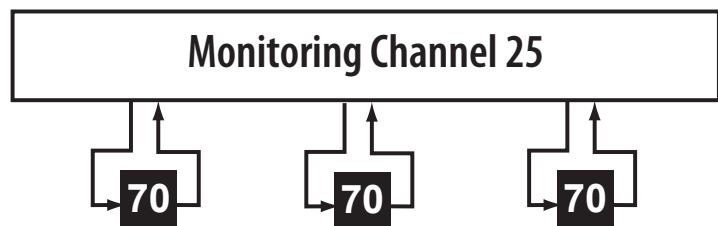

Every few seconds, the radio checks channel 70

**with DSC Watch on**

### **Scan**

You can save channels into memory and then use scan mode to monitor those channels from lowest to highest. If the radio detects a signal on a channel, it stays on that channel as long as the signal is received; when the signal stops, the radio continues scanning.

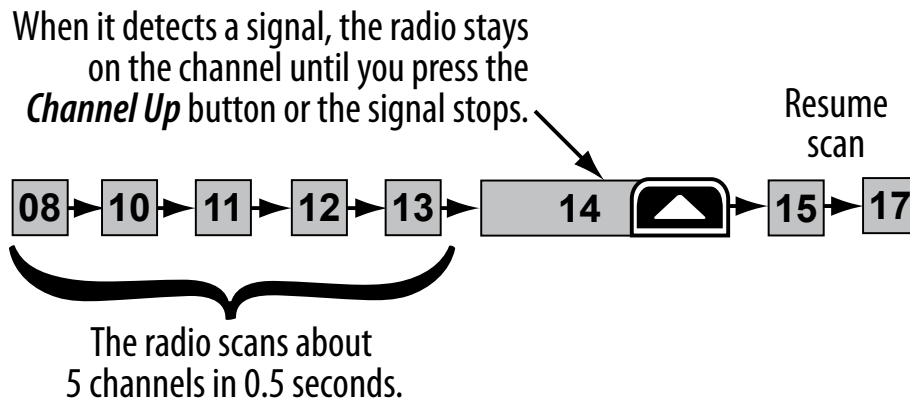

### *Using the radio in scan mode*

- To activate scan mode, press and hold **CLR/SCAN**.
- You must have at least two channels in memory to start a scan.
- You cannot transmit while in scan mode.
- To save a channel into memory, select the channel, then press and hold the **GPS/MEM** button. The **MEM** icon displays whenever you tune to that channel.
- To remove a channel from memory, set the radio to that channel, then press and hold the **GPS/MEM** button. The **MEM** icon no longer displays.
- When the radio stays on a channel, press **Channel Up** to leave that channel and resume scanning.
- To end the scan, press and hold the **CLR/SCAN** button again; the radio remains on the last scanned channel.

### *Scan mode with Weather Alert Watch*

If you activate Weather Alert Watch while in scan mode, the radio checks the most recently-used weather channel every few seconds, then continues scanning the next channel in memory:

## Memory Channel Scan

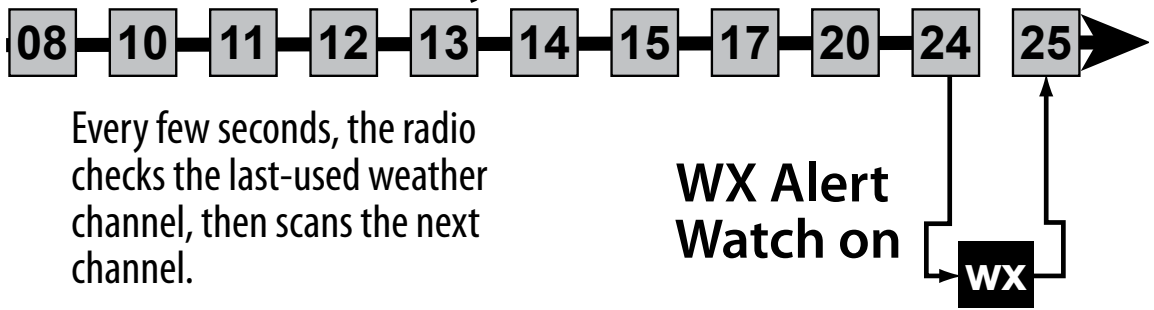

### *Scan mode with Triple Watch or Dual Watch*

If you activate Triple Watch while operating in scan mode, the radio checks channels 16 and 9 every few seconds, then goes on to scan the next channel; with Dual Watch turned on, the radio only checks channel 16:

## Memory Channel Scan

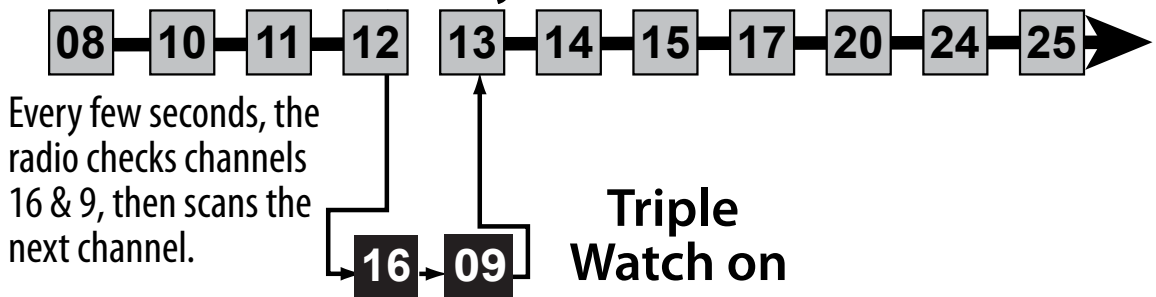

### *Both Weather Alert and Triple/Dual Watch in Scan mode*

You can activate Weather Alert Watch and Triple/Dual Watch at the same time. The radio performs both checks at their scheduled time:

## Memory Channel Scan

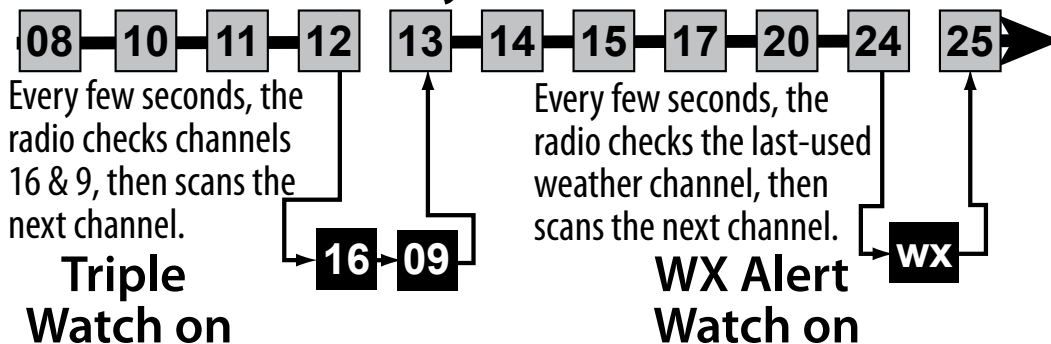

### *Scan mode with DSC Watch*

If you activate DSC Watch while operating in Scan mode, the radio checks channel 70 every few seconds.

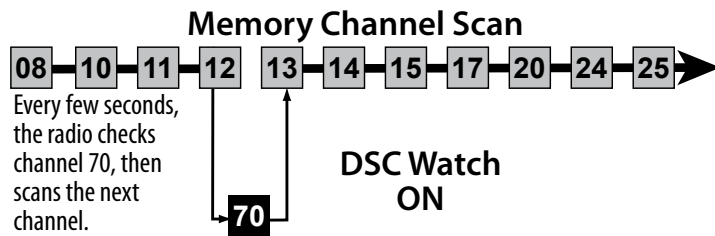

### ***Weather***

The NOAA weather channels now cooperate with the FCC to alert you of other hazards besides weather (child abduction alerts, nuclear, biological, etc.). In weather mode, the radio monitors one of the ten NOAA weather channels. If a weather alert signal is received in Weather Alert mode, the radio sounds an alert tone and the display blinks.

### *Using the radio in weather mode*

- You cannot transmit while in weather mode.
- To enter weather mode, press **WX/SOS**.
- To turn off the radio's alert tone, press any button.
- To cancel weather mode and return to the previous marine channel, press **WX/SOS** again.

### *Weather mode with Weather Alert Watch*

If you activate Weather Alert Watch while operating in weather mode, it operates as a type of “sleep mode:” the radio stays on the weather channel and mutes the speaker. If an alert is detected, the radio sounds an alert tone and turns the speaker back on. This mode is very useful when you are anchoring for the night but want to keep informed of hazards.

### *Weather mode with Triple Watch or Dual Watch*

If you activate Triple Watch while operating in weather mode, the radio checks channels 16 and 9 every few seconds; with Dual Watch turned on, the radio only checks channel 16.

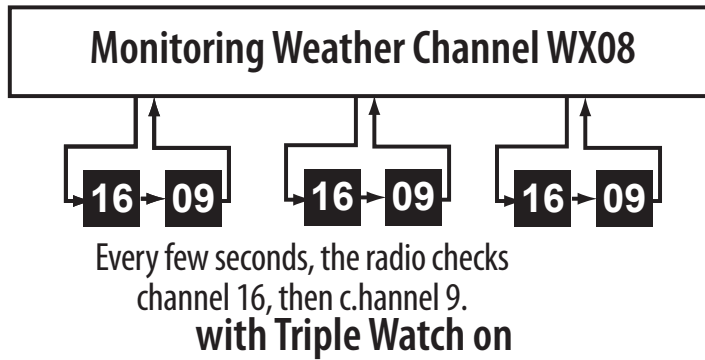

### *Weather mode with DSC Watch*

If you activate DSC Watch while operating in Weather mode, the radio checks channel 70 every few seconds.

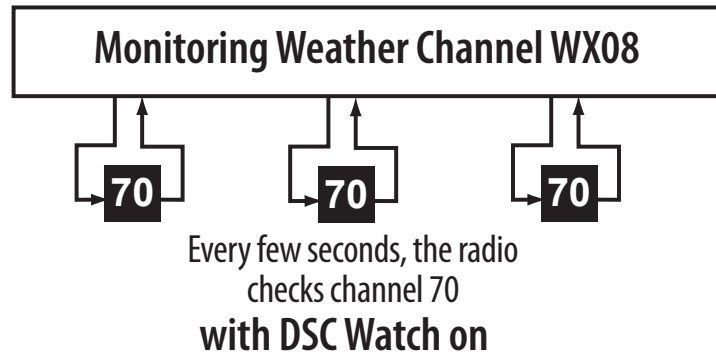

## SETTING UP THE HARDWARE

### Attaching the Antenna

The antenna detaches from the radio for easy shipping or storage. To attach the antenna to your radio, screw it tightly onto the anchor post at the top of the radio.

### Installing the Battery

Your radio comes with a rechargeable Lithium Ion battery; for shipping safety, the battery is not installed at the factory. The empty alkaline battery case is installed as a placeholder.

1. Insert the hook on the battery into the notch at the top of the battery compartment.

**Note:** Each time you remove the battery, check the rubber seal around the battery compartment. Make sure the seal is seated in the groove and



there is no dirt or debris on it. If the seal looks worn or damaged, contact customer service to order a replacement (see back cover page for contact information).

2. Lower the battery until it rests flat in the compartment.
3. Bring the battery latch up and snap it into place.

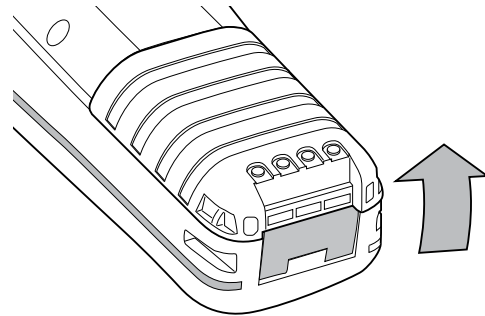

## Using Alkaline Batteries

The radio also comes with a battery case that holds four AAA-type alkaline batteries (not included). You can use alkaline batteries as a backup for the Li-Ion battery so you can still use your radio while your Li-Ion battery is recharging. For best performance, Uniden recommends using extra-strength alkaline batteries such as Duracell Ultra® batteries.

 **NOTE: When using alkaline batteries, transmit power is limited to a maximum of 2.5W.**

Follow these steps to use the alkaline battery case:

1. Hold the lower part of the case in one hand with the three battery contacts facing down. Use your thumb to hold the notch on the lower part of the case.
2. With your other hand, grip the upper part of the case and lift the cover open.
3. Align the batteries' positive and negative terminals with the drawing on the case and snap each battery into place.
4. Insert the two hooks on the lower part of the case into the notches on the cover; close the cover. (The cover fits snugly but you should not have to force it closed.)

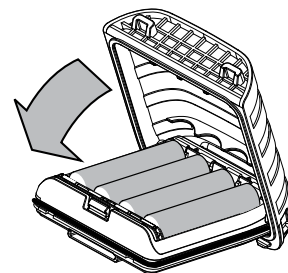
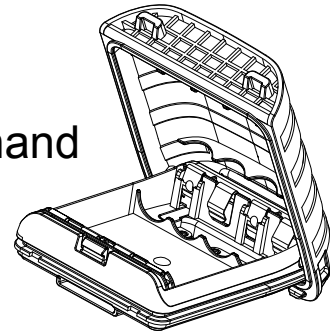

✎ **NOTE:** Each time you open the battery case, check the rubber seal. Make sure the seal is seated in the groove and there is no dirt or debris on it. If the rubber seal looks worn or damaged, contact customer service to order a replacement (see the back cover page for contact information).

5. Install the alkaline battery case in your radio just as you do the Li-Ion battery (see page E-13).

**WARNING!** The case is designed to prevent the accidental charging of alkaline batteries. Never use alkaline batteries in the radio without the battery case. Do not attempt to modify the battery case design.

## Mounting the Charger

You can mount the charger on any flat surface.

1. Use the two holes at the base of the charger as a template to mark the drill holes.
2. Using a 1/8-inch (or 3 mm) drill bit, drill two holes 1/2 inch (13mm) deep.
3. Use the provided screws to attach the charger to the surface.

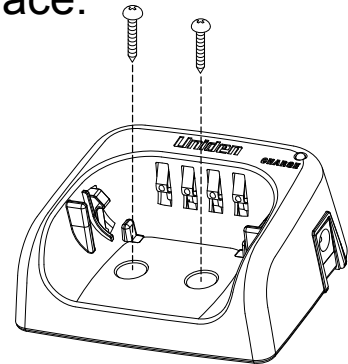

## Charging the Battery

Your radio includes a charger and a rechargeable battery pack. Place your radio in the charger with the display facing forward. Make sure that the CHARGE LED on the charger turns orange.

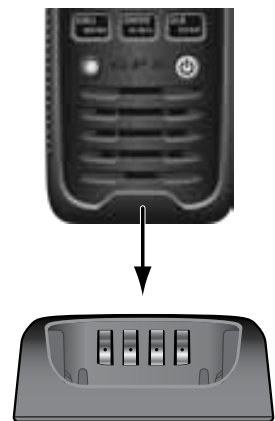

### Cautions:

- Use only the battery and charger supplied with this radio. Using a different charger or battery can damage the radio and create a risk of fire or shock.
- The charger is not waterproof. If the charger falls into

the water, unplug it before attempting to remove it from the water. After you remove the charger from the water, please contact Customer Service (see the back cover page for contact information).

- Wipe off dirt or shake water from your radio before placing in the charger if your radio gets dirty or wet.

### ***Important notes on charging the battery***

- Charge the battery fully before using the radio.
- Don't use the charger when the ambient temperature is below 0° C (32° F) or above 45° C (113° F).
- If the radio is powered down, the battery can charge in about seven hours. (If the radio is powered on, the battery takes longer to charge.)

## **SETTING UP YOUR RADIO**

### **Turning It On**

Press the **POWER** button for at least two seconds to turn the radio on. Press and hold it to turn the unit off.

### **Setting It Up**

Even though you can change your radio's settings at any time, you will probably want to establish initial settings when you have turned it on for the first time. You will adjust some of these settings on an as-needed basis, but some settings might only be set once and not need adjustment at all.

### ***Changing the Volume***

To change the speaker volume, press **VOL-SQ** to enter Volume Setting mode. The *VOL Level Adjustment* bar displays on the LCD. Press **CHANNEL UP** or **CHANNEL DOWN** to increase or decrease the volume levels (0 - 15).

### ***Setting the Squelch Level***

The squelch feature reduces static on the speaker

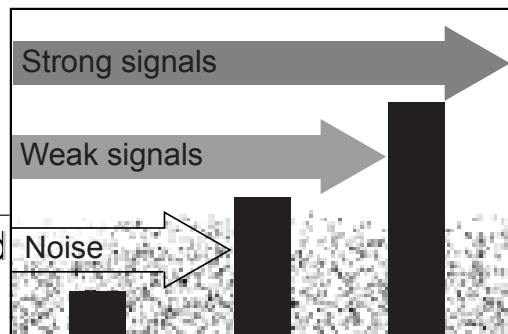



by filtering out any background channel noise. At the lowest squelch level, the speaker plays all signals, including any channel noise. Setting the squelch level higher filters out noise and lets only actual radio transmissions through.

While listening to a channel, press and hold **VOL-SQ** to enter Squelch Setting mode. The *SQUELCH Level* adjustment bar displays on the LCD. Press **CHANNEL UP** or **CHANNEL DOWN** to increase or decrease the squelch levels (0 - 15).

✎ **Note:** Setting the squelch level too high may prevent you from hearing weaker transmissions. If you are having difficulty hearing a transmission, try setting the squelch level lower.

### ***Setting the UIC Channel Mode (USA/CAN/INT)***

You can select marine channels for the USA, Canada, or International waters.

1. Press **MENU/CALL**. The *Normal* menu displays.
2. Select *Setup* and press **ENTER H/M/L**. The *Setup* menu displays.
3. Select *USA/CAN/INT* and press **ENTER H/M/L**. The *UIC Channels* screen displays.
4. Select the mode you want and press **ENTER H/M/L**.

### ***Setting Key Lock***

You can lock and unlock the keypad through the *Setup* menu. You can also unlock it by pressing and holding **MENU/CALL** for 2 seconds.

### ***Setting WX Alert Mode***

From the *SETUP* menu, select *WX Alert* mode to turn this mode ON for the radio to monitor weather channels and alert you to any broadcast weather alerts or notifications.

### ***Setting FIPS Codes***

FIPS codes identify geographic areas in the United States. FIPS codes allow you to receive only the SAME alert occurring in a specific area. You can enter a maximum of 30 FIPS codes.

1. Press **MENU/CALL** to bring up the *Normal* menu.
2. Select *Setup*, and then *FIPS Codes*.
3. *[New]* and a list of previously entered FIPS codes display. Enter a new FIPS code or select from the list of existing FIPS codes to edit or delete.

### **Adjusting the Lamp**

The backlight LCD function can be set to automatically dim after a predetermined time.

1. Press **MENU/CALL** and select *System*.
2. Select *Lamp Adjust*,
3. Lamp Adjust options are *Always On*, *Always Off*, or *Timer*.

### **Adjust the LCD Contrast**

This feature lets you adjust the LCD's contrast level. It also permits you to reverse the contrast completely. You can choose to have dark letters on a light background or light letters on a dark background.

Press

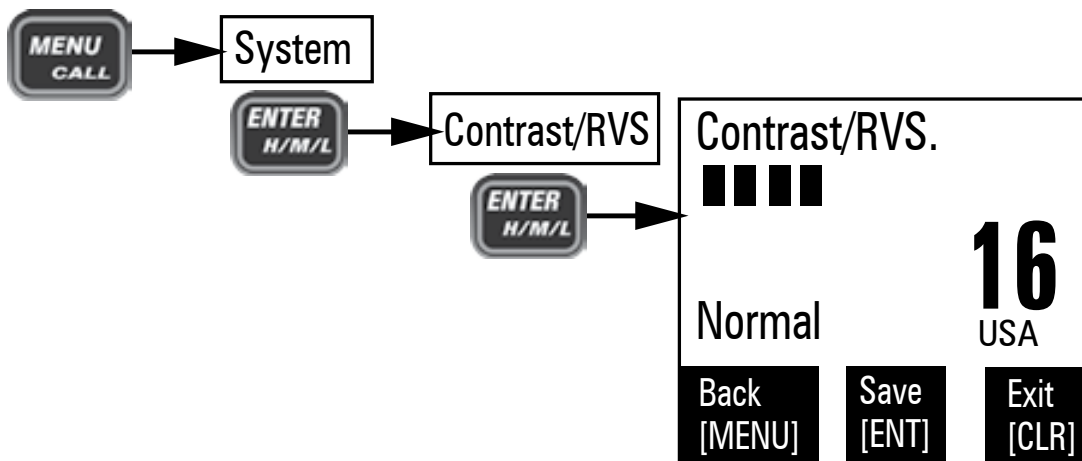

1. Press **MENU/CALL** and select *System*.
2. Select *Contrast/RVS*, then press **CHANNEL UP** or **CHANNEL DOWN** to adjust the contrast.
3. Pressing **DOWN** to turn the contrast all the way off will reverse the background/letters.

## ***Setting the Temperature Measure***

You can choose to have the temperature display in Celsius or Farenheit.

1. Press **MENU/CALL** and select *System*.
2. Select *Temperature*,
3. Temperature options are °C (*Celsius*) or °F (*Farenheit*).

## ***Turning the Key Beep On and Off***

Key beep is the tone that sounds when you press a key or a button. Press **MENU/CALL** to bring up the *Normal* menu. Select *System*, and then *Key Beep*. Press **CHANNEL UP** or **CHANNEL DOWN** to turn the key beep on or off.

## **Operating the Radio**

### ***Changing the Channel***

Press the **Channel Up** and **Channel Down** buttons briefly to scroll through the channels one channel at a time. Press and hold the **Channel Up** or **Channel Down** button to quickly scroll through the channels.

### ***Making a Transmission***

Select the channel you want to transmit on, then press and hold the **Push to Talk** button. Release the **Push to Talk** button when you're finished talking to let the other party respond.

- To prevent stuck microphone problems or situations where the **Push to Talk** button is pushed accidentally, the radio limits your talk time to 5 minutes in a single transmission.
- For the best sound quality, hold the microphone about two inches away from your mouth.
- See the channel lists starting on page E-23 for a list of receive-only channels.

## ***Changing the transmission level***

In most situations, 1 W transmission power is all you need. If you find yourself far away from other stations and have trouble getting a response, you may need to increase the transmission power. If your radio is powered by a Li-Ion battery, you can press and hold the **BOOST** button to transmit at 6W. Alkaline battery power boost is limited to 2.5W.

To increase the transmission power in increments:

1. Select the channel you want to transmit on.
2. Press **ENTER H/M/L** to switch to the next transmission power level (for example, from 1 W to 2.5 W, from 2.5 W to 6 W, or from 6 W back to 1 W).
3. The display shows the new transmission power as 6 W, *MID*, or *LOW*. The transmit power remains at the new setting until you change it again.

 **Note: Don't forget to change the transmission setting back to 1 W when you move close to other stations.**

Some channels (for example, channels 13 and 67) limit the transmission power to 1 W. When you tune to a limited-power channel, the radio automatically switches to 1 W. See the channel lists starting on page E-23 for a list of power-restricted channels.

## **DIGITAL SELECTIVE CALLING FEATURES**

### **What is DSC?**

Digital Selective Calling (DSC) is a standard that allows you to call other stations using their unique identification code (the Maritime Mobile Service Identity or MMSI number), just like you would call a phone number. To call another station, just enter that station's MMSI number and choose the voice channel you want to talk on. The radio uses channel 70 to transmit your MMSI number to the other station along with

the voice channel you requested. If the other station accepts your call, both radios automatically switch to the requested voice channel so you can talk to the other station.

DSC provides a system for automated distress calls. At the touch of a button, the radio can transmit your MMSI number, the nature of your distress, and your current position based on data from your GPS receiver. The radio repeats the distress call every few minutes until it receives an acknowledgement.

The DSC standard dedicates a VHF channel—channel 70—to digital transmissions only. Since digital transmissions require less bandwidth than voice transmissions, channel 70 avoids the problems of busy voice channels.

## Advanced DSC features

Your radio supports the following DSC features:

Feature	Menu Item	Function
Individual Call	Individual	Contact another vessel from your directory.
Group Call	Group	Contact all vessels that share your group MMSI code.
All Ships Call	All Ships	Broadcast to all vessels within range (used for safety or advisory messages).
Position Request	POS Request	Request the current location of another vessel.
Position Send	Position Send	Transmit your current location to another vessel.
Test Call	Test	Make sure your radio is working and configured correctly.

Feature	Menu Item	Function
Standby Mode	Standby	Automatically respond to all DSC calls with an “Unavailable” status.
Receive Log	Receive Log	Display the last 10 distress calls received by the radio and the last 50 general calls.
DSC Setup	DSC Setup	Accesses DSC menus. - POS Reply - Test Reply - Group MMSI - User MMSI - Directory - Auto CH SW

## MMSI Numbers

In order to use DSC features, you must be assigned a User MMSI number and program that number into your radio. Other than the User MMSI number, there are two other kinds of MMSI numbers: individual numbers for use by single boats and group numbers for use by fleets, boating organizations, event coordinators, etc.

You can get more information on MMSI numbers at these resources:

- The dealer where you purchased the radio
- Recreational boaters can obtain an MMSI number from the Boat Owner’s Association of the U.S. (<http://www.boatus.com/mmsi/> or call 800-536-1536) or Sea Tow Services International ([http://seatow.com/boating\\_safety/mmsi.asp](http://seatow.com/boating_safety/mmsi.asp))
- Commercial boaters need a ship station license to get an MMSI number. For more information, visit the Federal Communications Commission (FCC) website at <http://wireless.fcc.gov/marine/fctsht14.html>.

## Entering MMSI numbers

Use the **CHANNEL UP** and **CHANNEL DOWN** keys to scroll through numbers (and letters when entering names). When you see the number/letter you want, press the right arrow (**GPS/MEM**) to move the cursor to the next space. Press the left arrow (**WX/SOS**) to back up.

When using the **CHANNEL UP** and **CHANNEL DOWN** keys to enter a name, the alphabetic and numeric characters display in the following order:

- Capital letters (A through Z)
- Lower-case letters (a through z)
- Punctuation (/ ' + -)
- Numbers (0 through 9)
- One blank space

## Entering Your User MMSI Number

 **NOTE:** Be sure you have the correct User MMSI number before entering it in the radio. The radio only allows you to enter the User MMSI once. If you need to re-enter the User MMSI number, contact customer service (see back page for contact information).

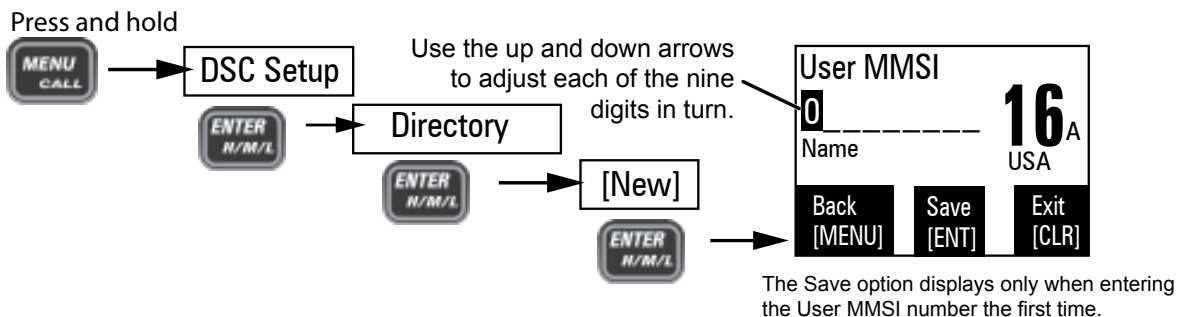

1. Press and hold **MENU/CALL** to display the *Call Menu*.
2. Scroll to *DSC Setup* and press **ENTER-H/M/L**. The *DSC Setup* menu displays.
3. Scroll to *User MMSI* and press **ENTER-H/M/L**. The *User MMSI* screen displays.
4. Select *[New]* and press **ENTER-H/M/L**.

5. Enter the MMSI number as described previously. When the ninth digit is correct, press **ENTER-H/M/L** and the cursor moves to the *Name* field.
6. Enter the name as described previously. When you have entered the name, press **ENTER-H/M/L**.
7. The radio displays the new MMSI number and name and asks you to confirm. To save this MMSI number and name, press **ENTER-H/M/L**. To cancel this MMSI number, press **CLR/SCAN**.

✎ **NOTE:** Be sure you entered the number correctly before confirming the entry. You can only save the user MMSI once.

8. Before saving the number, the radio displays the message *Confirm number! User MMSI data is Permanent!* Press **ENTER-H/M/L** to accept this MMSI. Press **CLR/SCAN** to return to the directory.

### **Entering a group MMSI number**

You can change the group MMSI number as often as you want. The first digit of a group MMSI is fixed at “0.” Follow the steps below to enter a group MMSI number into the radio:

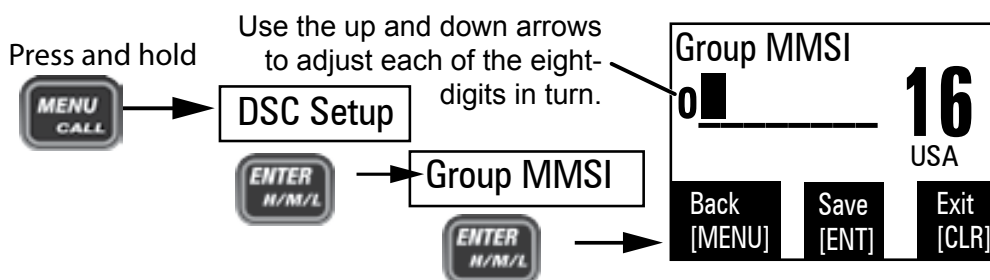

1. Press and hold **MENU/CALL** to display the *Call* Menu.
2. Scroll to *DSC Setup* and press **ENTER-H/M/L**. The *DSC Setup* menu displays.
3. Scroll to *Group MMSI* and press **ENTER-H/M/L**. The *Group MMSI* screen displays.
4. Group MMSI numbers always start with a 0, so that digit is already entered for you. Enter the MMSI number as described previously. When the ninth digit is correct,



press **ENTER-H/M/L**. The radio asks you to confirm.

5. To save this MMSI number, press **ENTER-H/M/L**. To cancel this MMSI number, press **CLR/SCAN**.

### **Entering an individual MMSI number**

Follow the steps below to enter individual MMSIs and names of other vessels into the directory:

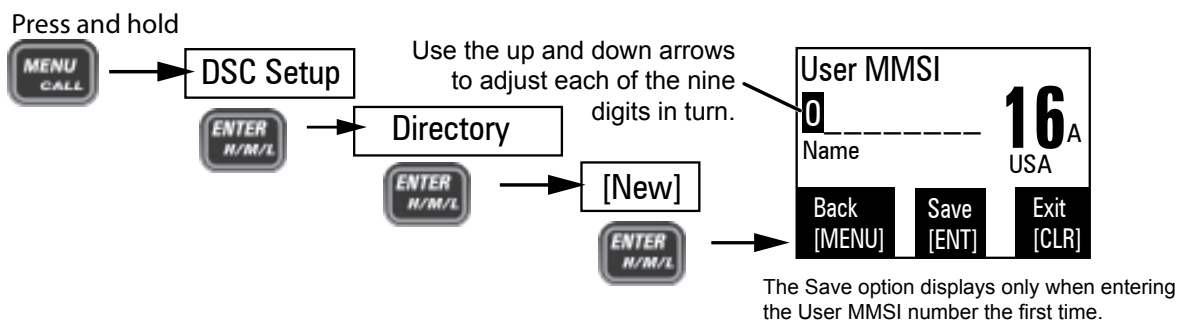

1. Press and hold **MENU/CALL** to display the *Call Menu*.
2. Scroll to *DSC Setup* and press **ENTER-H/M/L**. The *DSC Setup* menu displays.
3. Scroll to *Directory* and press **ENTER-H/M/L**. The *Directory* menu displays.
4. Select *[New]* and press **ENTER-H/M/L**.
5. Enter the MMSI number as described previously. When the ninth digit is correct, press **ENTER-H/M/L** and the cursor moves to the *Name* field.
6. Enter the name as described previously. When you have entered the name, press **ENTER-H/M/L**.
7. The radio displays the new MMSI number and name and asks you to confirm. To save this MMSI number and name, press **ENTER-H/M/L**. To cancel this MMSI number, press **CLR/SCAN**.

## **Using the Directory**

The directory lets you store up to 20 MMSI numbers of other stations so you can call them quickly. Entering the MMSI numbers and names of individual vessels is described on page \_\_\_\_\_.

Follow the steps below to edit the MMSI numbers in your

directory:

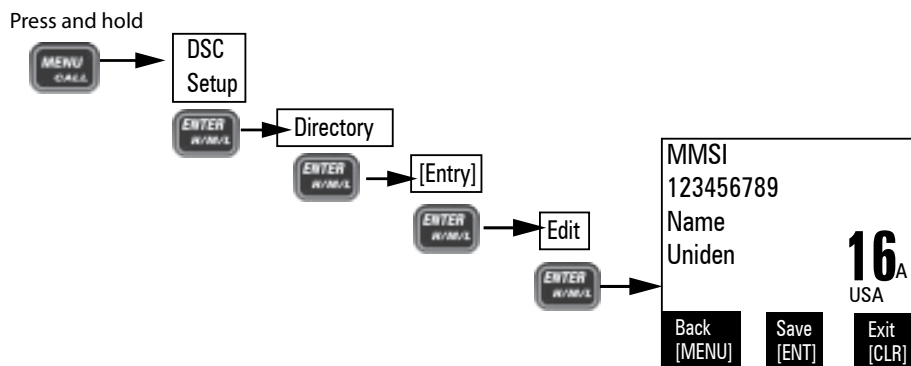

1. Press and hold **MENU/CALL** to display the *Call* menu.
2. Scroll to *DSC Setup* and press **ENTER-H/M/L**. The *DSC Setup* menu displays.
3. Scroll to *Directory* and press **ENTER-H/M/L**. The *Directory* screen displays. This screen lets you add a new MMSI or edit/delete an existing MMSI.
4. To enter a new MMSI, select [NEW] and follow the procedures for New MMSI Number on \_\_\_\_\_.
5. To edit an existing MMSI number/name, select the entry and press **ENTER-H/M/L**.
6. Select *Edit* and press **ENTER-H/M/L**. The MMSI number and name display. Edit accordingly and press **ENTER-H/M/L** when complete. A confirmation screen displays.
7. Press **ENTER-H/M/L** to accept the edits or **CLR/SCAN** to cancel. The radio returns to the directory list.
8. To delete the directory entry, select *Delete*.
9. When you are satisfied with the directory list, press **CLR/SCAN** to close the menu screen.

## Making DSC Calls

There are essentially four different types of DSC voice calls:

Call type	What it does	When to use it
Distress	Alerts all stations that you need assistance and sends them your current position.	In an emergency only.
Individual	Calls a single station using the User MMSL.	Any time you want to talk to another station.
Group	Calls all the stations that have the same Group MMSL as yours.	Any time you want with the whole group you are traveling with at the same time.
All Ships	Calls all stations within range of your radio.	Safety warnings (e.g., debris in the water) or any urgent situation.

Suppose you are coordinating safety for a sailboat race. Before the race starts, you instruct all the racers to enter your group MMSI number into their radios. During the race:

- Throughout the race, you use group calling to update the racers on the time, race status, and any course corrections.
- A power boat full of spectators comes a little too close to the race path. You use individual calling to contact the power boat and advise them to stay clear of the race.
- You see a rowboat entering the area, but since it doesn't have a radio, you can't communicate with the rowboat. You use all ships calling to alert all the other boats in the area of the possible danger.

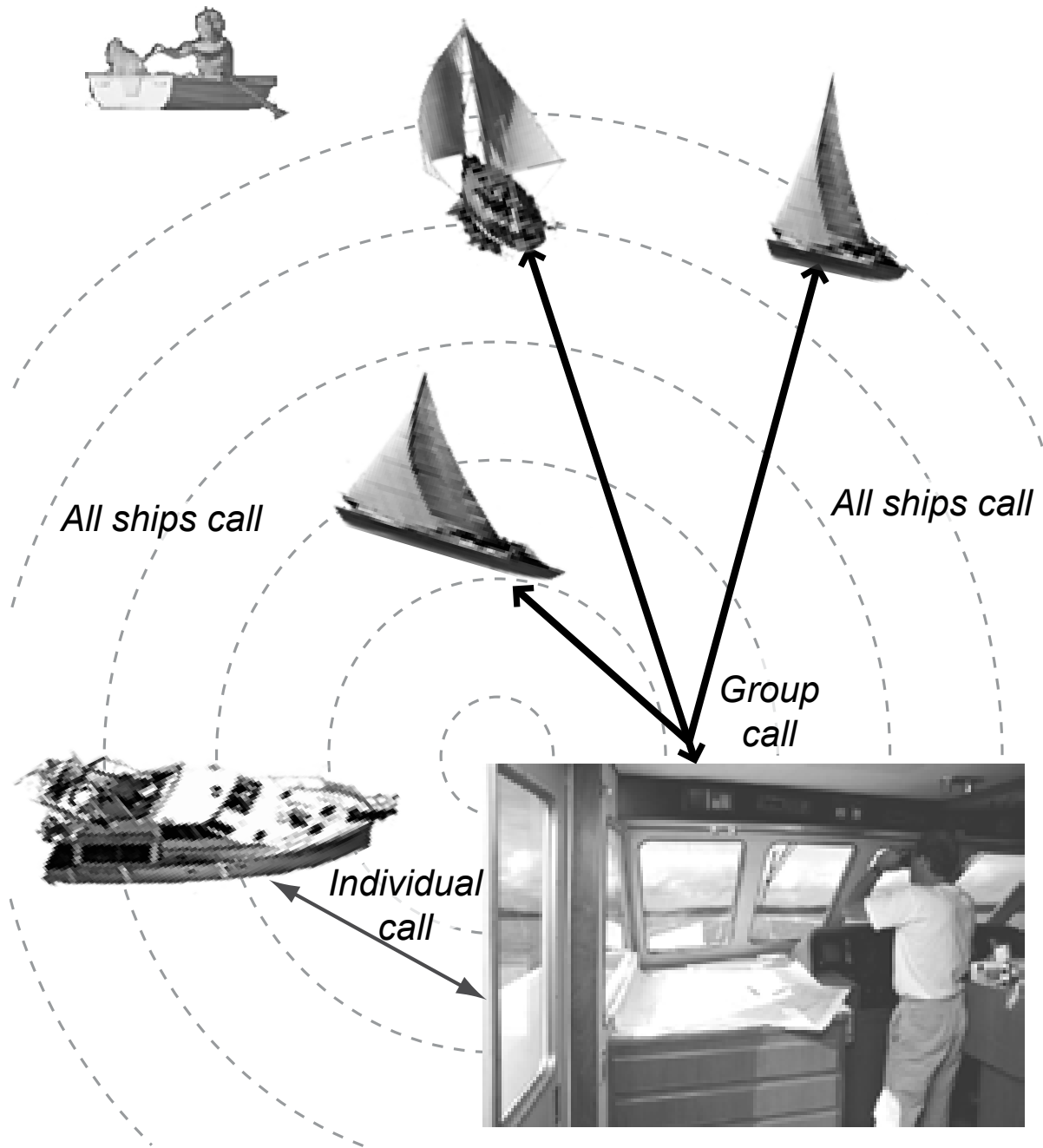

### ***Calling a single station (Individual Call)***

To call a single station with DSC, follow these steps:

1. Press and hold **MENU/CALL** to display the *Call* menu.
2. Select *Individual*.
3. The radio displays the names listed in your directory; use **CHANNEL UP** and **CHANNEL DOWN** to choose the directory entry you want to call and press **ENTER-H/M/L**.

If you want to call a station that is not in your directory,

select *Manual*. The radio prompts you to enter the MMSI number you want to call. Enter the MMSI number the same way you enter directory entries (see page 22) Enter all nine digits and press **ENTER-H/M/L**.

4. The radio prompts you to select a response channel. Use **CHANNEL UP** and **CHANNEL DOWN** to scroll through the available channels. When you reach the channel you want to use for a response, press the **ENTER-H/M/L** button.
5. The radio displays the MMSI number you are about to call and asks you to confirm. If you want to call the displayed MMSI number, select *Send* (press **ENTER-H/M/L**). To cancel the call, select *Exit* (press **CLR/SCAN**).
6. The radio automatically switches to channel 70 to transmit the call request.
  - When the other station accepts the call, both radios switch to the selected response channel for voice transmission.
  - If the other station cannot respond on the channel you selected, the radio displays *Not support CH*.

### ***Calling a particular group of stations (Group Call)***

Group calling calls all the stations that share your group MMSI. You must have a group MMSI programmed into the radio to make a group call, and the stations (boats) you are calling must have this same group MMSI programmed into their radios.

1. Press and hold **MENU/CALL** to display the *Call* menu.
2. Select *Group*.
3. The radio prompts you to select a response channel. Use **CHANNEL UP** and **CHANNEL DOWN** to scroll through the available channels. When you reach the channel you want to use for a response, press **ENTER-H/M/L**.
4. The radio asks you to confirm the call. Select *Send* (press **ENTER-H/M/L**) to continue with the call or select

*Exit* (press **CLR/SCAN**) to cancel the call.

5. The radio switches to channel 70 to transmit the call request then automatically switches to the designated response channel.

### ***Calling all stations (All-Ships Call)***

All ships calling contacts all DSC radios within range of your boat. You should only use all ships calling in the event of a Safety warning (such as debris in the water) or to request assistance in an Urgency (any situation where your vessel has a serious problem but is not yet in distress).

1. Open the *Call* menu.
2. Select *All Ships*, and then choose whether this is an Urgency call or a Safety call.
3. The radio asks you to confirm the call. Select *Send* (press **ENTER-H/M/L**) to continue with the call or select *Exit* (press **CLR/SCAN**) to cancel the call.
4. The radio automatically switches to channel 70 to transmit the call request then automatically switches to channel 16, the designated response channel for all-ships calling.

## **Making an automatic distress call**

If you have programmed your MMSI number, your radio can transmit an automated distress call with your current location and nature of the distress. The radio then monitors the channel 16 for a response and repeats the distress call every few minutes until it receives an acknowledgement.

**To send an automatic distress call, press and hold **DISTRESS** for three seconds. If no MMSI number has been programmed, the radio prompts you to enter your MMSI number.**

If you want to include the nature of your distress in the distress call, use the following distress procedure:

1. Press ***DISTRESS***.

2. The radio displays the list of distress conditions; use **CHANNEL UP** and **CHANNEL DOWN** to choose the nature of your distress, then press and hold **DISTRESS** for three seconds.

Undesignated	Sinking	Fire
Adrift	Flooding	Abandoning
Collision	Piracy.Armed	Grounding
Overboard	Capsizing	

### ***Canceling an automatic distress call***

While the radio is waiting for a response, it gives you the option of canceling the call. To cancel the distress call, choose *Exit* and press **CLR/SCAN**.

## **Receiving a DSC call**

If your radio receives an individual DSC call from another station, it sounds an incoming call tone and displays the name or MMSI number of the station calling you. To respond to the call, select *Send: Able-Comply*; the radio sends an acknowledgement and automatically switches to the designated response channel. To reject the call, select *Send: Unable-Comply*; the radio advises the other station that you are unable to respond to the call.

If the DSC request contains a response channel that you are not allowed to use, the radio displays *Not Support CH*; your only response option is *Send: Unable-Comply*.

If the radio receives a group or all ships call, it sounds an incoming call tone and automatically switches to the designated response channel.

### ***Receive log***

Just like your telephone's caller ID list, your radio keeps track of the calls you receive but do not answer. The receive log is useful if you have been off your boat or away from your

radio and want to see who has tried to contact you. The radio displays the last 10 distress calls and the last 50 non-distress calls that it received. If you have unread incoming DSC calls, the radio displays a Message icon. When you display all Distress and Other receiving logs, the message icon disappears.

Press and hold

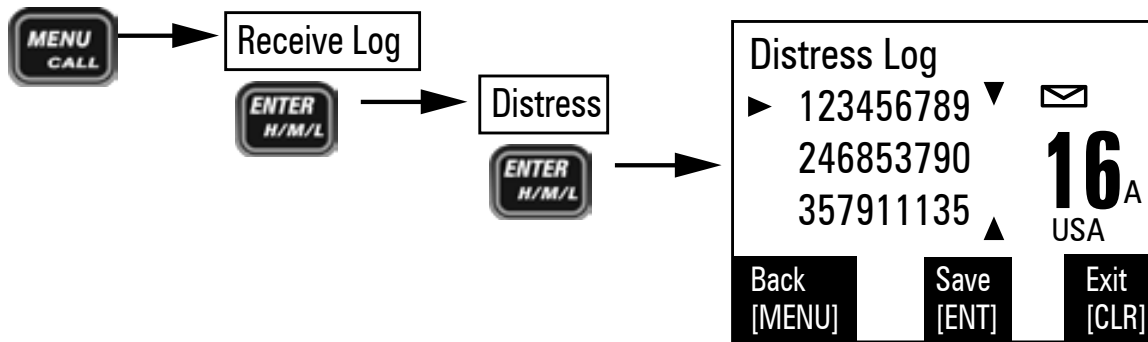

1. Press and hold **MENU/CALL** to display the *Call* menu.
2. Select *Receive Log*.
3. Select *Distress* to see the last 10 distress calls received by the radio. Select *Other* to see the last 50 normal calls received by the radio, then choose from *Individual*, *Group*, or *All Ships* calls.
4. Calls are listed in the order they were received, with the newest call shown first. The display blinks if there are new calls you have not reviewed. The Message icon also displays.
5. Select the call you want to see the details of. Use **CHANNEL UP** and **CHANNEL DOWN** to see all of the information. The log displays different information depending on type of call received. See the table below for the information stored for each type of call:

DSC Call Type	Receive Log Information
Distress	MMSI (or name), position, time, nature code.



DSC Call Type	Receive Log Information
Distress Acknowledge	MMSI (or name), distress MMSI, position, time, nature code.
Distress Relay	MMSI (or name), distress MMSI, position, time, nature code.
Distress Relay Acknowledge	MMSI (or name), distress MMSI, position, time, nature code.
Geographical	MMSI (or name), category code, communication channel number.
All Ships	MMSI (or name), category code, communication channel number.
Group	MMSI (or name), category code, communication channel number.
Individual	MMSI (or name), category code, communication channel number.
Individual Acknowledge	MMSI (or name), Completed/Unattended, category code, communication channel number.
Test	MMSI (or name), category code.
Test Acknowledge	MMSI (or name), category code.
Pos Reply	MMSI (or name), position, time, category code.
Pos Request	MMSI (or name), category code.
Pos Send	MMSI (or name), position, time, category code.

- From the log menu, select *Exit* to close the receive log and return to the mode you were in.

### ***Returning a call from the Receive Log***

You can return individual calls directly from the Receive Log. From the call detail screen, press **CHANNEL DOWN** until *Call Back* appears at the bottom of the display. Press

**ENTER-H/M/L** to return that station's call.

## Test Calls

### ***Making Test Calls (Test)***

You can use the test call feature to make sure your radio is working and configured correctly. To avoid overloading coastal receiving stations, you should limit test calls to these stations to once a week.

✎ **NOTE:** Many coastal stations have specific frequencies and MMSI numbers you should use for making test calls. Before making a test call to a coastal station, be sure to check the Local Notice to Mariners (LNM), issued every week by the US Coast Guard. The LNMs for each region are available online at <http://www.navcen.uscg.gov/lnm/default.htm>.

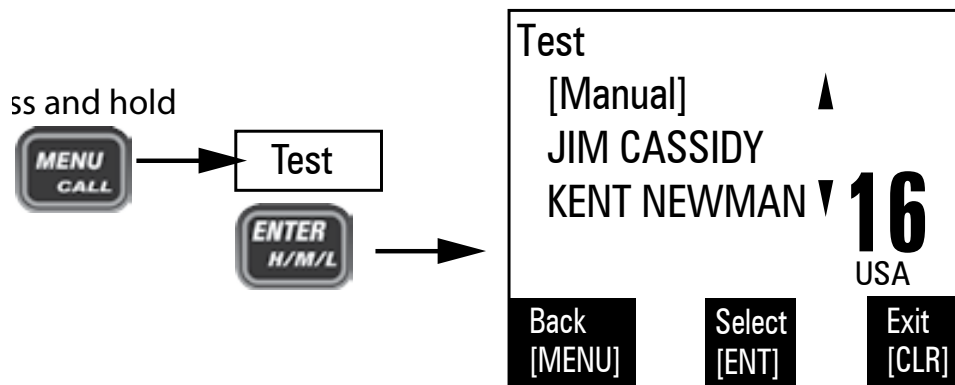

1. Press and hold **MENU/CALL** to display the *Call* menu.
2. Select *Test*.
3. The radio displays the names listed in your directory; use **CHANNEL UP** and **CHANNEL DOWN** to choose the directory entry you want to send a test call to and press **ENTER-H/M/L**.
4. If you want to send a test call to a station that is not in your directory, select *Manual*. The radio prompts you to enter the MMSI number you want to call. Enter the MMSI number the same way you enter directory entries

(see page **22**). Enter all nine digits and press **ENTER-H/M/L**.

5. The radio displays the MMSI number you are about to call and asks you to confirm. If you want to call the displayed number, select *Send*. To cancel the call, select *Exit*.

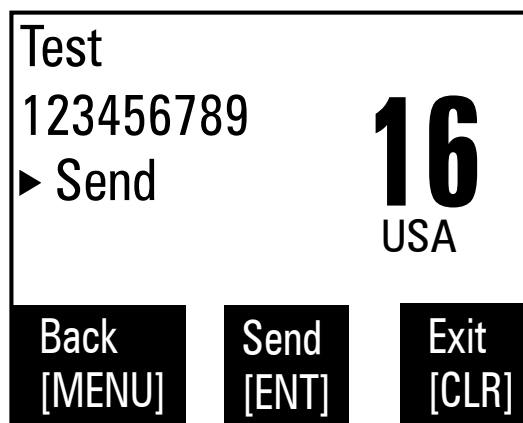

6. The radio automatically switches to channel 70 to transmit the test call request, then switches back to the last-used channel.
7. When the other station acknowledges the test call, the radio displays an acknowledgement screen.

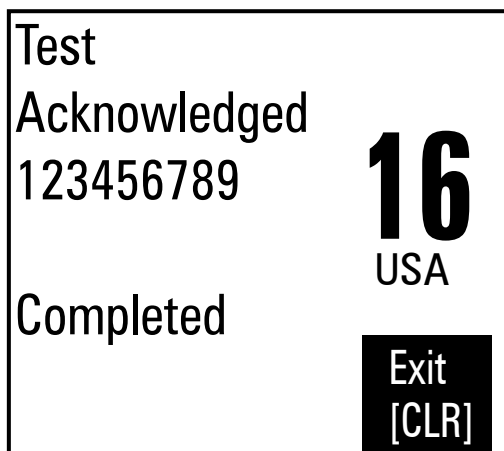

## Receiving Test Call Setup

When another station sends you a test call, you can select options to answer the test call manually or have the radio answer automatically.

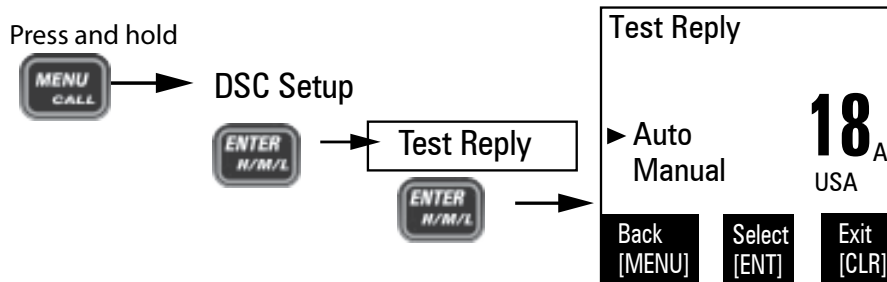

1. Press and hold **MENU/CALL** to display the *Call* menu.
2. Select *DSC Setup* and then *Test Reply*.
3. Choose *Auto* and press **ENTER-H/M/L**. The radio will automatically send an acknowledgement when it receives a test call.
4. To disable automatic test call reply, repeat the steps above and select *Manual*.

## Acknowledging Test Call Receipt

Different screens display depending on whether you set the *Test Reply* to *Auto* or *Manual*.

If *Test Reply* is set to *Auto*:



No action is necessary.

If *Test Reply* is set to *Manual*:

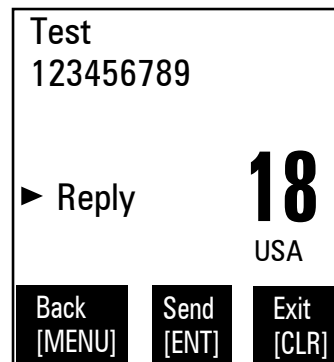

Select *Send* to send a reply.

# Position Request and Reply

## *POS Request*

Anytime you need to know where another boat currently is—to find your boating partners, to respond to a request for assistance, etc.—you can send a position request to their radio:

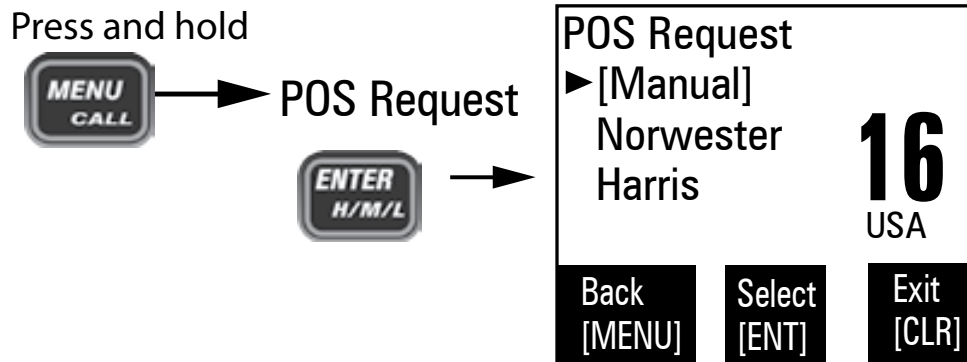

1. Press and hold **MENU/CALL** to display the *Call* menu.
2. Select *POS Request* and press **ENTER-H/M/L**.
3. The radio displays the names listed in your directory; use **CHANNEL UP** and **CHANNEL DOWN** to choose the directory entry you want to contact and press **ENTER-H/M/L**. If you want to contact a station that is not in your directory, select *Manual*. The radio prompts you to enter the MMSI number you want to call. Enter the MMSI number the same way you enter directory entries (see page [22](#)). Enter all nine digits and press **ENTER-H/M/L**.
4. The radio displays the MMSI number you are about to contact and asks you to confirm. If you want to request the position of the displayed MMSI number, select *Send*. To cancel the request, select *Exit*.
5. When the other station responds, the radio displays the MMSI number, the longitude, and the latitude of the other station. If your radio is connected to a chartplotter through the NMEA OUT connection (see page [34](#)), the position information will also be displayed on the plotter

screen.

6. If the other station does not have valid GPS data, the radio displays *No Position*.

### ***Position Reply***

When another station requests your current position, the radio displays the following screen:

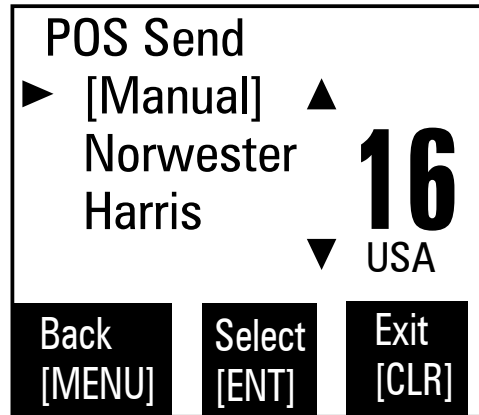

1. Select the vessel you want to transmit your position to or select *[Manual]* to enter that vessel's MMSI. Select *Select*.
2. Select *Send*. The screen displays the coordinates sent and the MMSI number they were sent to.
3. To reject the position request, select *Exit*.

### ***Enabling Automatic Position Reply***

If you want the radio to automatically transmit your current position whenever it receives a position request, you can enable automatic position reply. Most boaters activate automatic position reply for safety reasons or because they subscribe to a marine towing service. Sometimes—for example, in some competitive situations—you may not want other stations to get your position without your manual confirmation

1. Press and hold ***MENU/CALL*** to display the *Call* menu.
2. Select *DSC Setup* and then *POS Reply*.
3. Choose *Auto* and press ***ENTER-H/M/L***. The radio will automatically transmit your position when it receives a

position request.

4. To disable automatic position reply, repeat the steps above and select *Manual*.

### ***Position Send***

You can send your boat's position to someone else. If you are requesting assistance or using an all ships call to give a safety warning, you can send your current position so other stations know where you are:

1. Press and hold **MENU/CALL** to display the *Call* menu.
2. Select *Position Send*.
3. The radio displays the names listed in your directory; use **CHANNEL UP** and **CHANNEL DOWN** to choose the directory entry you want to contact and press **ENTER-H/M/L**. If you want to contact a station that is not in your directory, select *Manual*. The radio prompts you to enter the MMSI number you want to call. Enter the MMSI number the same way you enter directory entries (see page 22). Enter all nine digits and press **ENTER-H/M/L**.
4. The radio displays the MMSI number you are about to contact and asks you to confirm. If you want to transmit your position to the displayed MMSI number, select *Send*. To cancel the transmission, select *Exit*.
5. The radio transmits your MMSI number, your longitude, and your latitude to the other station.

### **Putting the radio into standby**

If you are leaving your radio or do not wish to answer any DSC calls, you can put your radio in standby mode. If your radio receives an individual call, it will automatically respond with a message that indicates your radio is currently unattended. Follow the steps below to put your radio in standby:

Press and hold

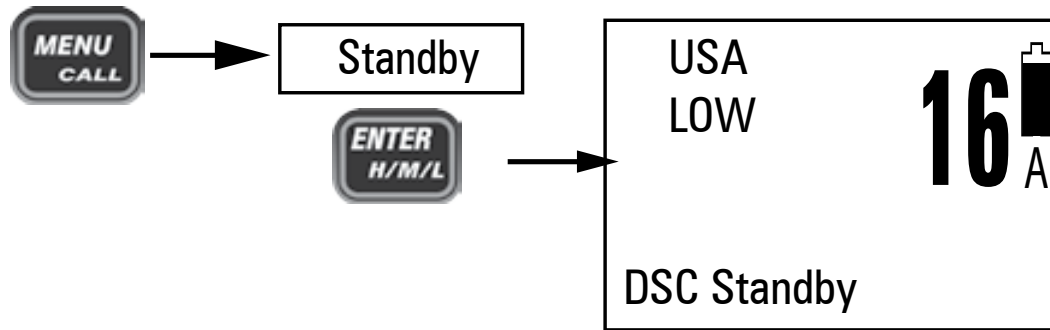

1. Press and hold **MENU/CALL** to display the *Call* menu.
2. Select *Standby* to place your radio in standby mode. The radio displays the standby screen, above.
3. To cancel standby and return to the mode your radio was in, press any button.

## Disabling automatic channel switching

If you are involved in a bridge-to-bridge call, you may not want the radio to automatically switch channels when it receives a DSC call. In cases like this, you can disable automatic channel switching. If you receive an individual call, the radio will respond with an unattended code, just as if the radio were in Standby.

Press and hold

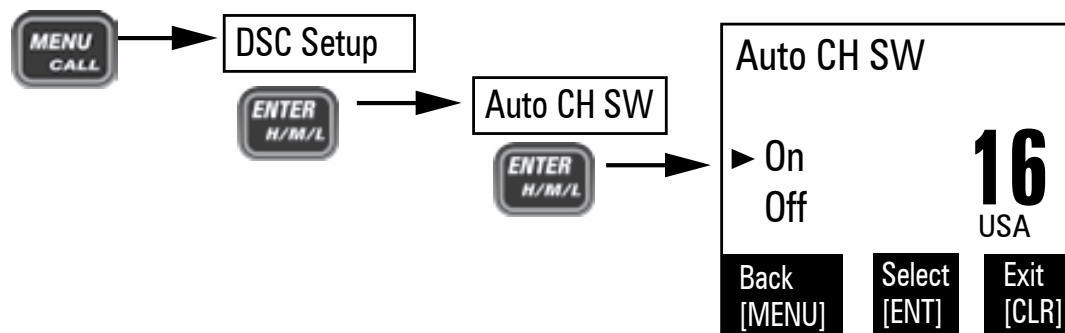

1. Press and hold **MENU/CALL** to display the *Call* menu.
2. Select *DCS Setup*, then *Auto CH SW*.
3. Select *Off* and press **ENTER-H/M/L**. The radio will not automatically switch channels until you reactivate this feature.



✎ **NOTE: Use this feature with caution. Deactivating automatic switching and then forgetting it can make it hard for you to receive DSC calls.**

If you have unread incoming DSC calls, the radio displays a message icon. You will be able to review who has called. The radio displays the last 10 distress calls and the last 50 non-distress calls it received (see the receive log on page 27).

## GPS FEATURES

### GPS Operation Overview

Your GPS system provides more than just your specific location. The *GPS Favorites* menus let you create a directory of favorite places and their coordinates so you can easily return there. Using the *GPS Setup* menus, you can determine power-saving options, measurement increments, and time settings

The radio is factory-preset to search for your geographic location when it is turned on for the first time. You can also use GPS menus to set up specific parameters for your GPS system.

### *Favorites Menu*

#### *Goto Menu*

The *Goto* menu allows you to select from a list of saved coordinates or to input coordinates manually.

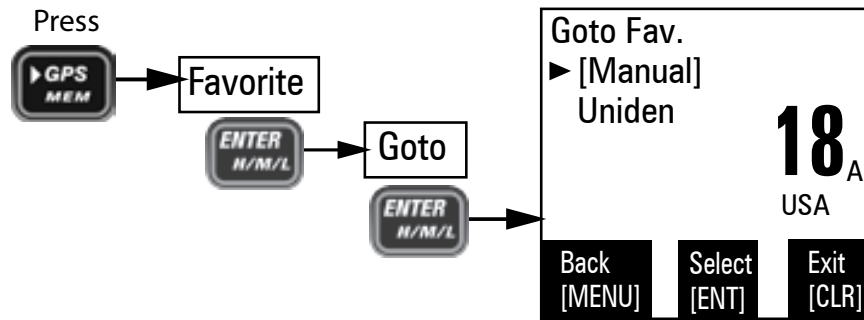

### Selecting [Manual]

1. From the *Goto Fav.* screen, select *[Manual]*.
2. Manually input coordinates. When the last digit is entered, the screen displays *Go* and *Save*.
3. Select *Go* to display the coordinates and the compass bearing and begin traveling towards that destination.
4. Select *Save* to save the location into a Favorites directory. When you select *Save*, the screen prompts you to name these coordinates.
5. When you have entered a name for the saved coordinates, they will appear on the *Goto Fav.* screen as a selection.

### Selecting a Goto Favorite

1. From the *Goto Fav.* screen, select from the directory entries listed.
2. The screen displays three options: *Go*, *Delete*, and *Edit*.
3. Select *Go* to display the coordinates and the compass bearing and begin traveling towards that destination.  
Select *Delete* to delete the entry.  
Select *Edit* to change the entry.

### Add Menu

The *Add* menu allows you to save your current position to the Favorite directory.

### GPS Setup Menu

The GPS Setup menu has eight sub-menus.

Sub-menu	What it does
Unit Power	Turns the GPS module off to conserve power
Popwer Save	Adjusts the GPS module's power level
Time Adjust	Adjusts local time
Daylight Save	Adjusts for Daylight Savings Time
SOG Unit	Determines Speed over Ground measurements
GPS Module	Selects the primary or secondary GPS module to use
NMEA Output	Selects NMEA Output
Compass	Displays your current heading.

## ADDITIONAL FEATURES

### Using the Strobe LED

You can use this radio in an emergency. If you press and hold **WX/SOS**, the radio turns on the strobe SOS high-intensity LED light on your radio and it blinks "S O S" in international Morse Code. This will make it easier for rescuers to find you faster.

 **Your radio operates normally when the SOS LED strobe is activated.**

Press and hold **WX/SOS** to turn the strobe LED on and off. You can also turn the strobe LED on without it sending an SOS pattern.

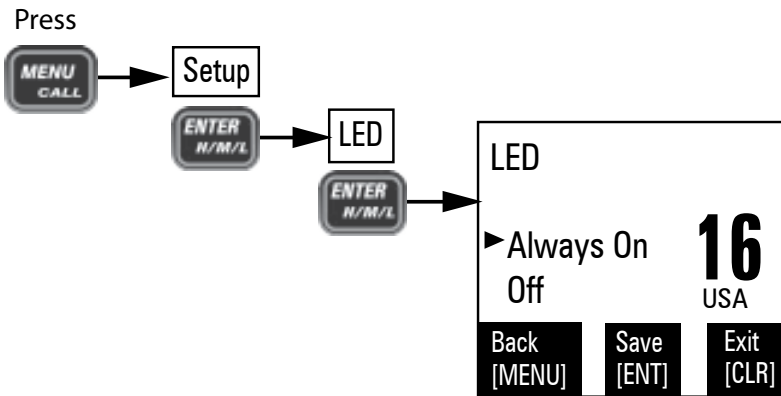

1. Display the normal menu and press *Setup*.
2. Select *LED*. The screen displays the *LED* menu.
3. Select *Always On* to light the strobe LED or *Off* to turn it off.

## Renaming Channels

If you discover that a marine radio channel has a different common name in your local area, you can change the name of that channel to make it easier for you to use (see the channel lists beginning on page [40](#) for the default channel names). To rename a channel, follow the steps below:

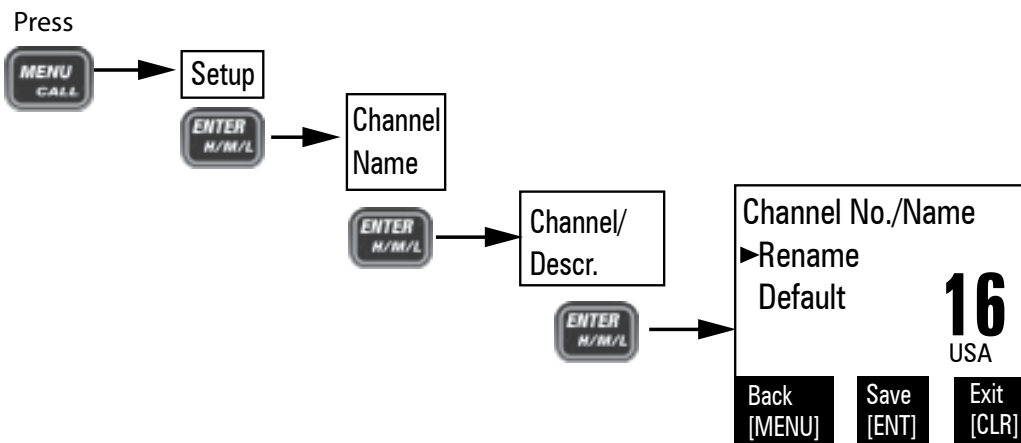

1. Display the normal menu and choose the *Setup* sub-menu.
2. Select *Channel Name*. The screen displays the list of channels.
3. Use **CHANNEL UP** and **CHANNEL DOWN** to choose

the channel you want to change and press **ENTER-H/M/L**.

4. Select *Rename* to enter a new name for this channel. The radio prompts you to enter a new name for this channel. Each name can be up to 12 characters. Use **CHANNEL UP** and **CHANNEL DOWN** to change the name as described previously (see page \_\_\_\_\_).
5. When you finish entering the name, the radio displays the new channel name and asks you to confirm. To save this new channel name, select *Save*; to cancel the change, select *Exit*. The radio returns to the channel list.
6. To restore a channel back to its original name, select the channel and choose *Default*.
7. When you are satisfied with the channel list, select *Exit* to close the menu screen.

## MAINTENANCE AND TROUBLESHOOTING

Due to its rugged design, your radio requires very little maintenance. However, it is a precision electronic instrument, so you should follow a few precautions:

- If the antenna has been damaged, do not transmit except in an emergency situation. Transmitting with a defective antenna may cause further radio damage.
- You are responsible for continued FCC technical compliance of your radio.
- You should arrange for periodic performance checks with your Uniden dealer.

### Common Questions

Problem	Things to Try
The radio won't turn on.	Charge the radio.

Problem	Things to Try
The power LED on the charger doesn't turn on.	<ul style="list-style-type: none"> <li>- Don't use the charger when the ambient temperature is below 0° C (32° F) or above 45° C (113° F).</li> <li>- Make sure the charging contacts on the radio and charger are clean.</li> <li>- Replace the battery.</li> </ul>
The radio won't transmit.	<p>Make sure you are not in Weather or Scan mode.</p> <p>Make sure you are not trying to transmit on a receive-only channel or transmit at the wrong power level for this channel (see the channel lists starting on page E-23).</p> <p>Check the battery power level; if it's low, charge the battery before trying to transmit.</p> <p>Make sure the duration of each transmission is less than 5 minutes.</p>
I can't hear anything from the speaker.	Adjust the squelch level; it is probably too high.
Noise comes out of the speaker all the time	Adjust the squelch level; it is probably too low.
I can transmit, but no one can hear me.	Check your UIC channel settings: does the area you are in use different channel assignments?
I'm not getting hazard alerts.	Make sure Weather Alert Watch is turned on.
The display flashes, and I don't know why.	The channel number on the display will flash if the radio is in a watch mode or in scan mode. Try turning off scanning, Weather Alert Watch, Triple Watch, or Dual Watch (see page E-7).
Where can I find my radio's serial number?	The serial number is on a plate inside the battery compartment.

# SPECIFICATIONS

<b>General</b>	
Channels	All US/International/Canada marine channels
	10 Weather channels
Freq. Control	PLL
Freq. Tol.	Transmit: 1.5 PPM (at 77°F/25°C)
	Receive: 1.5 PPM (at 77°F/25°C)
Oper. Temp.	-4°F (-20°C) to +122°F(+50°C)
Antenna	Flexible Whip
Microphone	Built-in Electret type
Display	Liquid Crystal Display
Speaker	8Ω 0.5 W
Power Source	Rechargeable Lithium Ion Battery 7.4V 1040 mAh
Size (without antenna)	5.95 (H) x 2.56 (W) x 1.77 (D) inch
	151 (H) x 65 (W) x 45 (D) mm
Weight	11.29 oz (320g) (w/battery and antenna)
<b>Transmitter</b>	
Frequency Range	156~158 MHz
Frequency Stability	±10 PPM
Power Output	1.0 W & 2.5W & 6W
Spurious Emissions	70 dBc
Current Drain	1500 mA (5W)
<b>Receiver</b>	
Type	Double Conversion Super Heterodyne Phase Locked Loop system for Local Oscillator
Frequency Range	156~164 MHz
Sensitivity	0.20 μV for 12dB SINAD
Squelch Sensitivity	Threshold 0.12μV

Audio Frequency Response	+6 dB @ 500 Hz; -6 dB @ 2000Hz
Adjacent Channel Selectivity	70 dB @ ±25 kHz
Audio Output Power	0.34 W @10% THD
Current Drain	Squelched: 38 mA; Max. Audio: 160 mA

## Channels and Frequencies (MHz)

### *US channel frequencies and names*

US Marine Channels				
Ch	RX Freq	TX Freq	Status	Name
1A	156.050	156.050	Simplex	Vessel traffic system/commercial
5A	156.250	156.250	Simplex	Vessel traffic system/commercial
6	156.300	156.300	Simplex	Inter-ship safety
7A	156.350	156.350	Simplex	Commercial
8	156.400	156.400	Simplex	Commercial
9	156.450	156.450	Simplex	Non commercial
10	156.500	156.500	Simplex	Commercial
11	156.550	156.550	Simplex	Vessel traffic system
12	156.600	156.600	Simplex	Vessel traffic system
13	156.650	156.650	Simplex, 1W	Bridge to bridge
14	156.700	156.700	Simplex	Vessel traffic system
15	156.750	Inhibit	Receive only	Environmental
16	156.800	156.800	Simplex	Distress, safety, and calling
17	156.850	156.850	Simplex, 1W	Govt maritime control
18A	156.900	156.900	Simplex	Commercial
19A	156.950	156.950	Simplex	Commercial
20	161.600	157.000	Duplex	Port operation
20A	157.000	157.000	Simplex	Port operation
21A	157.050	157.050	Simplex	Coast guard only
22A	157.100	157.100	Simplex	Coast guard
23A	157.150	157.150	Simplex	Coast guard only



<b>US Marine Channels</b>				
<b>Ch</b>	<b>RX Freq</b>	<b>TX Freq</b>	<b>Status</b>	<b>Name</b>
24	161.800	157.200	Duplex	Marine operator
25	161.850	157.250	Duplex	Marine operator
26	161.900	157.300	Duplex	Marine operator
27	161.950	157.350	Duplex	Marine operator
28	162.000	157.400	Duplex	Marine operator
63A	156.175	156.175	Simplex	Vessel traffic system
65A	156.275	156.275	Simplex	Port operation
66A	156.325	156.325	Simplex	Port operation
67	156.375	156.375	Simplex, 1W	Bridge To Bridge
68	156.425	156.425	Simplex	Non Commercial
69	156.475	156.475	Simplex	Non Commercial
70	156.525	Inhibit	Receive only	Digital Selective Calling
71	156.575	156.575	Simplex	Non Commercial
72	156.625	156.625	Simplex	Non Commercial (Ship-Ship)
73	156.675	156.675	Simplex	Port Operation
74	156.725	156.725	Simplex	Port Operation
75	156.775	156.775	Simplex, 1W	Port Operation
76	156.825	156.825	Simplex, 1W	Port Operation
77	156.875	156.875	Simplex, 1W	Port Operation (Ship-Ship)
78A	156.925	156.925	Simplex	Non Commercial
79A	156.975	156.975	Simplex	Commercial
80A	157.025	157.025	Simplex	Commercial
81A	157.075	157.075	Simplex	Government
82A	157.125	157.125	Simplex	Government
83A	157.175	157.175	Simplex	Coast Guard
84	161.825	157.225	Duplex	Marine Operator
85	161.875	157.275	Duplex	Marine Operator
86	161.925	157.325	Duplex	Marine Operator
87	157.375	157.375	Simplex	Marine Operator
88	157.425	157.425	Simplex	Commercial (Ship-Ship)

## ***Canadian channel frequencies and names***

<b>Canadian Marine Channels</b>				
<b>Ch</b>	<b>RX Freq</b>	<b>TX Freq</b>	<b>Status</b>	<b>Name</b>
1	160.650	156.050	Duplex	Marine Operator
2	160.700	156.100	Duplex	Marine Operator
3	160.750	156.150	Duplex	Marine Operator
4A	156.200	156.200	Simplex	Canadian Coast Guard
5A	156.250	156.250	Simplex	Vessel Traffic System
6	156.300	156.300	Simplex	Inter-Ship Safety
7A	156.350	156.350	Simplex	Commercial
8	156.400	156.400	Simplex	Commercial
9	156.450	156.450	Simplex	Boater Calling Channel
10	156.500	156.500	Simplex	Commercial
11	156.550	156.550	Simplex	Vessel Traffic System
12	156.600	156.600	Simplex	Vessel Traffic System
13	156.650	156.650	Simplex, 1W	Bridge To Bridge
14	156.700	156.700	Simplex	Vessel Traffic System
15	156.750	156.750	Simplex, 1W	Environmental
16	156.800	156.800	Simplex	Distress, safety, calling
17	156.850	156.850	Simplex, 1W	State Control
18A	156.900	156.900	Simplex	Commercial
19A	156.950	156.950	Simplex	Canadian Coast Guard
20	161.600	157.000	Duplex, 1W	Port Operation
21A	157.050	157.050	Simplex	Canadian Coast Guard
22A	157.100	157.100	Simplex	Canadian Coast Guard
23	161.750	157.150	Duplex	Marine Operator
24	161.800	157.200	Duplex	Marine Operator
25	161.850	157.250	Duplex	Marine Operator
26	161.900	157.300	Duplex	Marine Operator
27	161.950	157.350	Duplex	Marine Operator
28	162.000	157.400	Duplex	Marine Operator
60	160.625	156.025	Duplex	Marine Operator

<b>Canadian Marine Channels</b>				
<b>Ch</b>	<b>RX Freq</b>	<b>TX Freq</b>	<b>Status</b>	<b>Name</b>
61A	156.075	156.075	Simplex	Canadian Coast Guard
62A	156.125	156.125	Simplex	Canadian Coast Guard
63A	156.175	156.175	Simplex	Port Operation
64	160.825	156.225	Duplex	Marine Operator
64A	156.225	156.225	Simplex	Port Operation
65A	156.275	156.275	Simplex	Port Operation
66A	156.325	156.325	Simplex, 1W	Port Operation
67	156.375	156.375	Simplex	Bridge To Bridge
68	156.425	156.425	Simplex	Non Commercial
69	156.475	156.475	Simplex	Non Commercial
70	156.525	Inhibit	Receive only	Digital Selective Calling
71	156.575	156.575	Simplex	Non Commercial
72	156.625	156.625	Simplex	Non Commercial
73	156.675	156.675	Simplex	Port Operation
74	156.725	156.725	Simplex	Port Operation
75	156.775	156.775	Simplex, 1W	Port Operation
76	156.825	156.825	Simplex, 1W	Port Operation
77	156.875	156.875	Simplex, 1W	Port Operation
78A	156.925	156.925	Simplex	Inter Ship
79A	156.975	156.975	Simplex	Inter Ship
80A	157.025	157.025	Simplex	Inter Ship
81A	157.075	157.075	Simplex	Canadian Coast Guard
82A	157.125	157.125	Simplex	Canadian Coast Guard
83	161.775	157.175	Duplex	Canadian Coast Guard
83A	157.175	157.175	Simplex	Canadian Coast Guard
84	161.825	157.225	Duplex	Marine Operator
85	161.875	157.275	Duplex	Marine Operator
86	161.925	157.325	Duplex	Marine Operator
87	157.375	157.375	Simplex	Port Operation
88	157.425	157.425	Simplex	Port Operation

## ***International channel frequencies and names***

<b>International Marine Channels</b>				
<b>Ch</b>	<b>RX Freq</b>	<b>TX Freq</b>	<b>Status</b>	<b>Name</b>
1	160.650	156.050	Duplex	Marine operator
2	160.700	156.100	Duplex	Marine operator
3	160.750	156.150	Duplex	Marine operator
4	160.800	156.200	Duplex	Marine operator
5	160.850	156.250	Duplex	Marine operator
6	156.300	156.300	Simplex	Inter-ship safety
7	160.950	156.350	Duplex	Marine operator
8	156.400	156.400	Simplex	Commercial (ship-ship)
9	156.450	156.450	Simplex	Boater calling channel
10	156.500	156.500	Simplex	Commercial
11	156.550	156.550	Simplex	Vessel traffic system
12	156.600	156.600	Simplex	Vessel traffic system
13	156.650	156.650	Simplex	Bridge to bridge
14	156.700	156.700	Simplex	Vessel traffic system
15	156.750	156.750	Simplex, 1W	Environmental
16	156.800	156.800	Simplex	Distress, safety, calling
17	156.850	156.850	Simplex, 1W	Govt maritime control
18	161.500	156.900	Duplex	Port operation
19	161.550	156.950	Duplex	Commercial
20	161.600	157.000	Duplex	Port operation
21	161.650	157.050	Duplex	Port operation
22	161.700	157.100	Duplex	Port operation
23	161.750	157.150	Duplex	Marine operator
24	161.800	157.200	Duplex	Marine operator
25	161.850	157.250	Duplex	Marine operator
26	161.900	157.300	Duplex	Marine operator
27	161.950	157.350	Duplex	Marine operator
28	162.000	157.400	Duplex	Marine operator
60	160.625	156.025	Duplex	Marine operator

<b>International Marine Channels</b>				
<b>Ch</b>	<b>RX Freq</b>	<b>TX Freq</b>	<b>Status</b>	<b>Name</b>
61	160.675	156.075	Duplex	Marine operator
62	160.725	156.125	Duplex	Marine operator
63	160.775	156.175	Duplex	Marine operator
64	160.825	156.225	Duplex	Marine operator
65	160.875	156.275	Duplex	Marine operator
66	160.925	156.325	Duplex	Marine operator
67	156.375	156.375	Simplex	Bridge to bridge
68	156.425	156.425	Simplex	Non commercial
69	156.475	156.475	Simplex	Non commercial
70	156.525	Inhibit	Receive only	Digital Selective Calling
71	156.575	156.575	Simplex	Non commercial
72	156.625	156.625	Simplex	Non commercial
73	156.675	156.675	Simplex	Port operation
74	156.725	156.725	Simplex	Port operation
75	156.775	156.775	Simplex, 1W	Port operation
76	156.825	156.825	Simplex, 1W	Port operation
77	156.875	156.875	Simplex	Port operation (ship-ship)
78	161.525	156.925	Duplex	Port operation
79	161.575	156.975	Duplex	Port operation
80	161.625	157.025	Duplex	Port operation
81	161.675	157.075	Duplex	Port operation
82	161.725	157.125	Duplex	Port operation
83	161.775	157.175	Duplex	Port operation
84	161.825	157.225	Duplex	Marine operator
85	161.875	157.275	Duplex	Marine operator
86	161.925	157.325	Duplex	Marine operator
87	157.375	157.375	Simplex	Marine operator
88	157.425	157.425	Simplex	Marine operator

### ***Weather channel frequencies and names***

<b>Channel</b>	<b>RX</b>	<b>Channel</b>	<b>RX</b>
WX01	162.5500	WX06	162.5000
WX02	162.4000	WX07	162.5250
WX03	162.4750	WX08	161.6500
WX04	162.4250	WX09	161.7750
WX05	162.4500	WX10	163.2750

# REGULATIONS AND SAFETY WARNINGS

**WARNING!** Read this information before using the radio.

## Maritime Radio Services Operation

**Warning!** This transmitter will operate on channels/frequencies that have restricted use in the United States. The channel assignments include frequencies assigned for exclusive use of the U.S. Coast Guard, use in Canada, and use in international waters. Operation on these frequencies without proper authorization is strictly forbidden. See pages E-23 through E-29 for tables of the available channels and their uses. If you are still not certain which channels to use, see the FCC maritime radio page at the FCC website (<http://wireless.fcc.gov/marine/>) or contact the FCC Call Center at 1-888-CALL-FCC. For individuals requiring a license, such as commercial users, you should obtain a license application from your nearest FCC field office (for US users) or Industry Canada (for Canadian users).

## Basic Radio Guidelines

You should familiarize yourself with the rules on marine radios and be aware of which rules apply to your boat. Complete guidelines for all ship and marine radio types can be found at the US Coast Guard website under the topic Radio Info for Boaters (the direct link is <http://www.navcen.uscg.gov/marcomms/boater.htm>). Here are a few guidelines that affect nearly all boaters.

- If you have a VHF radio on your boat, you must maintain a watch on channel 16 (156.800 MHz) whenever the radio is not being used to communicate. Starting in 2004, if a radio is carried, it must be on and set to channel 16 whenever your boat is underway.
- If you hear a distress call, wait a few minutes to let a shore station or Coast Guard vessel respond. If no other

station has responded after 5 minutes, you must respond to the distress call.

- Do not make false mayday or distress calls as a prank or to test your radio. (This is essentially like making a false 9-1-1 call; you may be subject to fines.)

## **FCC/Industry Canada Information**

- Certification: FCC Part 80 or RSS-182
- Output Power: 6W
- Emission: 16K0F3E
- Transmitter Frequency Range: 156.025-157.425 MHz

This device complies with Part 15 of the FCC Rules.

Operation is subject to the condition that this device does not cause harmful interference.

Unauthorized changes or modifications to this equipment may void compliance with the FCC Rules. Any change or modification must be approved in writing by Uniden. Changes or modifications not approved by Uniden could void the user's authority to operate the equipment.

## **FCC RF Exposure Information**

In August 1996 the Federal Communications Commission (FCC) of the United States with its action in Report and Order FCC 96-326 adopted an updated safety standard for human exposure to radio frequency electromagnetic energy emitted by FCC regulated transmitters. Those guidelines are consistent with the safety standard previously set by both U.S. and international standards bodies. The design of the radio complies with the FCC guidelines and these international standards.

Never allow children to operate the radio without adult supervision and the knowledge of the following guidelines.

**WARNING!** It is up to the user to properly operate this radio transmitter to insure safe operation. Please adhere to the following:

- Use only the supplied or an approved antenna.



Unauthorized antennas, modifications, or attachments could impair call quality, damage the radio, or violate FCC regulations.

- Do not use the radio with a damaged antenna. If a damaged antenna comes into contact with the skin, a minor burn may result. Please contact your local dealer for a replacement antenna.

## **Body-Worn Operation**

This device was tested for typical body-worn operations using the supplied belt-clip. To maintain compliance with FCC RF exposure requirements, body-worn operations are restricted to the supplied belt-clip. For hand-held operation, the radio should be held 1 inch from the user's face. The use of accessories that do not satisfy these requirements may not comply with FCC RF exposure requirements and should be avoided. For more information about RF exposure, please visit the FCC website at [www.fcc.gov](http://www.fcc.gov).

## **Lithium Ion Battery Warning**

This equipment contains a rechargeable Lithium Ion battery. The rechargeable Lithium Ion battery contained in this equipment may explode if disposed of in a fire.

Do not short-circuit the battery.

Do not charge the rechargeable battery used in this equipment in any charger other than the one specified in the owner's manual. Using another charger may damage the battery or cause the battery to explode.

**NOTE: Li-Ion batteries must be recycled or disposed of properly.**

Avoid exposing the battery (whether attached to the radio or not) to direct sunlight, heated cars, or temperatures below  $-4^{\circ}\text{F}$  ( $-20^{\circ}\text{C}$ ) or above  $+140^{\circ}\text{F}$  ( $+60^{\circ}\text{C}$ ). Exposing the chemical contained within the battery pack to temperatures above  $+140^{\circ}\text{F}$  ( $+60^{\circ}\text{C}$ ) may cause the battery to rupture, fail, or reduce performance.

In case of exposure to the cell contents, wash the affected area thoroughly, and seek medical attention.

## **Three Year Limited Warranty**

**WARRANTOR:** UNIDEN AMERICA CORP. (“Uniden”)

**ELEMENTS OF WARRANTY:** Uniden warrants, for three years, to the original retail owner, this Uniden Product to be free from defects in materials and craftsmanship with only the limitations or exclusions set out below.

**WARRANTY DURATION:** This warranty to the original user shall terminate and be of no further effect 36 months after the date of original retail sale. The warranty is invalid if the Product is (A) damaged or not maintained as reasonable or necessary, (B) modified, altered, or used as part of any conversion kits, subassemblies, or any configurations not sold by Uniden, (C) improperly installed, (D) serviced or repaired by someone other than an authorized Uniden service center for a defect or malfunction covered by this warranty, (E) used in any conjunction with equipment or parts or as part of any system not manufactured by Uniden, or (F) installed or programmed by anyone other than as detailed by the Operating Guide for this product.

**STATEMENT OF REMEDY:** In the event that the product does not conform to this warranty at any time while this warranty is in effect, warrantor will repair the defect and return it to you without charge for parts, service, or any other cost (except shipping and handling) incurred by warrantor or its representatives in connection with the performance of this warranty. THE LIMITED WARRANTY SET FORTH ABOVE IS THE SOLE AND ENTIRE WARRANTY PERTAINING TO THE PRODUCT AND IS IN LIEU OF AND EXCLUDES ALL OTHER WARRANTIES OF ANY NATURE WHATSOEVER, WHETHER EXPRESS, IMPLIED OR ARISING BY OPERATION OF LAW, INCLUDING, BUT NOT LIMITED TO ANY IMPLIED WARRANTIES OF MERCHANTABILITY OR FITNESS FOR A PARTICULAR PURPOSE. THIS

WARRANTY DOES NOT COVER OR PROVIDE FOR THE REIMBURSEMENT OR PAYMENT OF INCIDENTAL OR CONSEQUENTIAL DAMAGES. Some states do not allow this exclusion or limitation of incidental or consequential damages so the above limitation or exclusion may not apply to you.

**LEGAL REMEDIES:** This warranty gives you specific legal rights, and you may also have other rights which vary from state to state. This warranty is void outside the United States of America.

**PROCEDURE FOR OBTAINING PERFORMANCE OF WARRANTY:** If, after following the instructions in this Operating Guide you are certain that the Product is defective, pack the Product carefully (preferably in its original packaging). Include evidence of original purchase and a note describing the defect that has caused you to return it. The Product should be shipped freight prepaid, by traceable means, or delivered, to warrantor at:

Uniden America Corporation  
Parts and Service Division  
4700 Amon Carter Boulevard  
Fort Worth, TX, 76155  
(800) 554-3988

**QUESTIONS?**  
Visit our website at  
[www.uniden.com](http://www.uniden.com) or  
call 1-800-297-1023.

**QUESTIONS?**  
Contactez-nous au  
[www.uniden.com](http://www.uniden.com) ou  
appelez 1-800-297-1023.