

REVISED EDITION



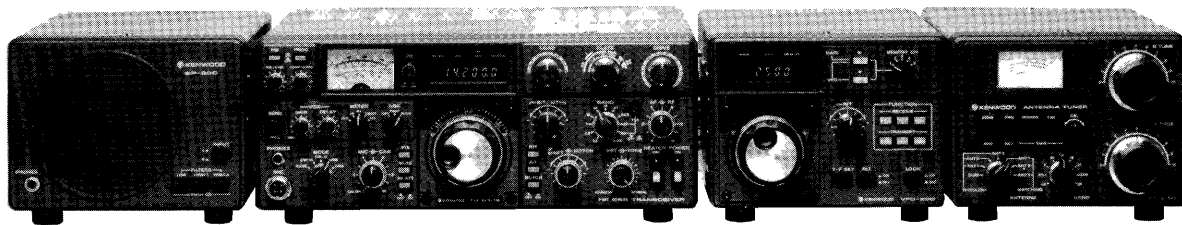
# SERVICE MANUAL

## Model TS-830S, M

EXCEPT USA MARKET

## SP-230, VFO-230, AT-230, DS-2

(W) TYPE ONLY



SP-230

TS-830S

VFO-230

AT-230

### CONTENTS

#### TS-830S, M

SPECIFICATIONS .....	2
CIRCUIT DESCRIPTION .....	3
AC VOLTAGE CONVERSION .....	9
INSIDE VIEWS .....	10
PC BOARD VIEWS .....	11
PARTS LIST .....	18
PACKING .....	26
DISASSEMBLY .....	27
ADJUSTMENTS .....	32
LOCATION OF ADJUSTMENTS .....	42
LEVEL DIAGRAM .....	44
TS-830M SCHEMATIC DIAGRAM .....	61
TS-830S SCHEMATIC ABBREVIATION .....	62
TS-830S SCHEMATIC DIAGRAM .....	63
BLOCK DIAGRAM .....	64

#### VFO-230

BLOCK DIAGRAM .....	45
SPECIFICATIONS .....	46
CIRCUIT DESCRIPTION .....	46
PC BOARD VIEWS .....	49
PARTS LIST .....	51
ADJUSTMENTS .....	53
PACKING .....	53
AC VOLTAGE CONVERSION .....	56
SCHEMATIC DIAGRAM .....	57
<b>AT-230</b> .....	58
<b>DS-2</b> .....	60
<b>SP-230</b> .....	BACK COVER

## HF SSB TRANSCEIVER

# SPECIFICATIONS

## [GENERAL]

<b>Frequency Range</b> .....	160 m Band 1.8 ~ 2.0 MHz 80 m Band 3.5 ~ 4.0 MHz 40 m Band 7.0 ~ 7.3 MHz * 30 m Band 10.1 ~ 10.15 MHz (10.0 MHz WWV) 20 m Band 14.0 ~ 14.35 MHz * 17 m Band 18.068 ~ 18.168 MHz 15 m Band 21.0 ~ 21.45 MHz * 12 m Band 24.89 ~ 24.99 MHz 10 m Band 28.0 ~ 29.7 MHz
<b>Modes</b> .....	SSB/CW: 830S, SSB/AM/CW: 830M
<b>Power Requirement</b> .....	120V AC (220V modifiable), 50/60 Hz: 830S (K) 220/240V AC (selectable), 50/60Hz: 830S (T) (W) (X) 120/220V AC (selectable), 50/60Hz: 830M
<b>Power Consumption</b>	Transmit: 295 watts Receive: 32 watts (with heater off)
<b>Dimensions</b> .....	333 (13.3) × 133 (5.3) × 333 (13.3) mm (inch)
<b>Weight</b> .....	13.5 kg (29.8 lbs)

## [TRANSMITTER]

<b>* Final Power Input</b> .....	220W PEP for SSB operation : 830S, M 180W DC for CW operation : 830S, M 80W DC for AM operation : 830M
<b>Audio Input Impedance</b> .....	500Ω ~ 50 kΩ
<b>RF Output Impedance</b> .....	50Ω ~ 75Ω
<b>Frequency Stability</b> .....	Within 1 kHz during the first hour after 1 minute of warmup. Within 100 Hz during any 30 minute period after warmup.
<b>Carrier Suppression</b> .....	Better than 40 dB
<b>Sideband Suppression</b> .....	Better than 60 dB
<b>Spurious Radiation</b> .....	Better than 60 dB
<b>Harmonic Radiation</b> .....	Better than 40 dB
<b>Audio Freq. Response</b> .....	400 to 2,600 Hz, within - 6 dB
<b>3rd Order Intermodulation Distortion</b> .....	Better than - 36 dB

## [RECEIVER]

<b>Receiver Sensitivity</b> .....	0.25 μV at 10 dB S + N/N for SSB, CW : 830S, M 2 μV at 10 dB S + N/N for AM : 830M
<b>Image Ratio</b> .....	Better than 60 dB
<b>IF Rejection</b> .....	Better than 80 dB
<b>Receiver Selectivity</b>	
<b>SSB/CW WIDE</b> .....	2.4 kHz (- 6 dB), 3.6 kHz (- 60 dB) : 830S, M
<b>CW NARROW</b> .....	With YK-88C (option) 500 Hz (- 6 dB), 1.5 kHz (- 60 dB) With YK-88CN (option) 270 Hz (- 6 dB), 1.1 kHz (- 60 dB) With YG-455C (option) 500 Hz (- 6 dB), 820 Hz (- 60 dB) With YG-455CN (option) 250 Hz (- 6 dB), 500 Hz (- 60 dB)
<b>AM</b> .....	6 kHz (- 6 dB), 11 kHz (- 60 dB) : 830M
<b>Variable Bandwidth</b>	
<b>SSB with 2.4 kHz filter</b> .....	500 Hz ~ 2.4 kHz (- 6 dB) continuously variable : 830S, M
<b>CW with 500 Hz filter</b> .....	150 Hz ~ 500 Hz (- 6 dB) continuously variable : 830S With optional filter YK-88C and YG-455C added.
<b>AM</b> .....	4.5 kHz ~ 6 kHz (- 6 dB) continuously variable : 830M
<b>Notch-filter Attenuation</b> .....	Better than 40 dB
<b>Audio Output Impedance</b> .....	8 ~ 16Ω
<b>Audio Output</b> .....	1.5W (8Ω)

\*Will transmit on the new 30, 17, and 12 meter bands. Diodes installed for preventing accidental transmission before government amateur authorization.

NOTE: The circuit and ratings may change without notice due to developments in technology.

## INTRODUCTION

The TS-830S is a dual conversion transceiver using two intermediate frequencies, 8.83 MHz and 455 kHz. However, this differs from transceivers of the so called Collins type (such as the TS-520) in that the bandwidth of both intermediate frequencies is narrowed for performing VBT operation. Therefore, the TS-830S can basically be considered a single conversion transceiver with an 8.83 MHz IF. Operation of the transmitter is opposite in process to the receiver. An SSB signal generated at 455 kHz is converted to 8.83 MHz, and is then mixed with the PLL (local oscillator output) to produce the final transmission frequency. The circuitry is hybrid with vacuum tubes used only in the driver (12BY7A) and final-stage power amplifier (6146B's). The PLL circuit generates a heterodyne frequency for each band, a counter reference signal, and a 25 kHz marker, all from a single crystal oscillator. The TS-830S incorporates an IF SHIFT circuit, VBT, VOX (also used for CW semi break-in), side tone circuit, RF speech processor, transmission monitor circuit, noise blanker, XTAL calibrator, notch filter, and etc.

## RECEIVER CIRCUIT

The signal coming from the antenna is routed through step-up antenna coil via an RF ATT switch and IF trap. MOS FET (Q1 3SK73) amplifies this signal. Approximately 9 dB of negative feedback is applied to the RF amplifier to reduce noise and expand the amplifiers range of linear operation. The signal passes through a buffer amplifier (Q2 2SK125) and is mixed with the PLL VCO output by a balanced mixer (Q3, Q4 2SK125). The signal is now converted to the first intermediate frequency, 8.83 MHz. Entering the IF unit, this signal is amplified by Q1 (2SK125), passes through ceramic filter CF1 and the NB gating circuit, and is applied to crystal filter XF1 whose center frequency is 8.83 MHz. The signal leaving the crystal filter is mixed with the VBT local oscillator output at 8.375 MHz by a balanced mixer (Q2, Q3 3SK73) where it is converted to the second intermediate frequency, 455 kHz. The signal then passes through ceramic filter CF2 whose center frequency is 455 kHz, and is amplified by Q4 (3SK73). It then is fed to the notch circuit, Q5 through Q7 (2SC1815). After being amplified by Q8 (3SK73), it is demodulated to an audio signal by the product detector (D20~D23, IN60 X4).

In the AF unit, the audio signal is amplified by Q3 (2SC2240), passes through the AF GAIN control and after being amplified by the power amplifier Q4 (HA1368R), drives the speaker.

Item	Rating
Center frequency $f_0$	8.830 MHz
3 dB bandwidth	$f_0 \pm 5$ kHz or more, total 25 kHz or more
30 dB bandwidth	100 kHz or less
Input level (at 80 dB $\mu$ output)	93.5 dB or less
Ripple (within 3 dB bandwidth)	1 dB or less
Spurious response	20 dB or more within $f_0 \pm 1.5$ MHz
Input and output impedance	330 $\Omega$

**Table 1. Ceramic filter pair (L72-0310-05) 2 pcs. SFA8.83MF combined (IF unit, CF1A & B)**

Item	Rating
Center frequency $f_0$	8830 kHz
Center frequency deviation	Within $\pm 150$ Hz at 6 dB
Pass bandwidth	$\pm 1.35$ kHz or more at 6 dB
Attenuation bandwidth	$\pm 1.7$ kHz or less at 20 dB $\pm 2.5$ kHz or less at 60 dB $\pm 3.4$ kHz or less at 80 dB
Ripple	2 dB or less
Loss	6 dB or less
Guaranteed attenuation	80 dB or more within $f_0 \pm 1$ MHz
Input and output impedance	600 $\Omega$ / 15 pF

**Table 2. Crystal filter (L71-0222-05) YK88S1 (IF unit, XF1)**

Item	Rating
Center frequency	455 kHz $\pm 0.2$ kHz
6 dB bandwidth	2.7 kHz or more
60 dB bandwidth	4.5 kHz or less
Guaranteed attenuation (0.1 ~ 1 MHz)	60 dB or more
Spurious (600 ~ 700 kHz)	40 dB or more
Ripple (within 6 dB bandwidth)	2 dB or less
Loss	6 dB
Input and output impedance	2 k $\Omega$

**Table 4. Ceramic filter (L72-0314-15) CFJ455K5 (IF unit, CF2)**

Item	Rating
Center frequency $f_0$	8831.5 kHz
Center frequency deviation	Within $\pm 250$ Hz at 6 dB
Pass bandwidth	$\pm 3.0$ kHz or more at 6 dB
Attenuation bandwidth	$\pm 6$ kHz or less at 60 dB $\pm 10$ kHz or less at 80 dB
Ripple	2 dB or less
Loss	3 dB within $\pm 2$ dB
Guaranteed attenuation ( $f_0 \pm 10$ kHz to $f_0 \pm 1$ MHz)	80 dB or more
Input and output impedance	600 $\Omega$ / 15 pF

**Table 3. Crystal filter (L71-0223-05) YK-88A (IF unit, XF2)**

Item	Rating
Center frequency $f_0$	456.5 kHz
6 dB bandwidth	$\pm 3$ kHz or more
50 dB bandwidth	$\pm 9$ kHz or less
Ripple ( $f_0 \pm 2$ kHz)	2 dB or less
Loss	6 dB or less
Guaranteed attenuation ( $f_0 \pm 100$ kHz)	60 dB or more
Input and output impedance	2.0 k $\Omega$

**Table 5. Ceramic filter (L72-0322-05) CFW 456.5HT (IF unit, CF3)**

## TRANSMITTER CIRCUIT

Audio input picked up by the microphone comes to the IF unit and is amplified by Q19~21. The input circuit adapts to any microphone impedance of from 500 ohms to 50k ohms. This amplified output is converted to a DSB signal by the balanced modulator D29-32 (1N60 x 4), passes through buffer amplifier Q22 (2SK19), a 455kHz ceramic filter, and the output appears as a SSB signal. This signal passes either buffer amplifier Q23 (2SC1815), or the speech processor consisting of Q24, 26, and 27. Then the first transmit mixer (Q28 3SK73) converts this to an 8.83 MHz SSB signal. After passing the 8.83 MHz crystal filter and being amplified by Q29 (3SK73), the signal is applied to the second transmit mixer in the RF unit. This double balanced mixer (Q6, Q7 3SK73), mixes the signal with the PLL VCO output to convert to the final Transmit frequency. Output is amplified by the driver tube (V1 12BY7A) and then by the final power amplifier (two 6146B's) and is applied to the antenna via a  $\pi$ -matching network.

## PLL CIRCUIT

The PLL signal is synthesized from the VFO, CAR, and VCO outputs. The TS-830S employs a programmable divider in the PLL to synthesize the heterodyne frequency from the standard reference oscillator frequency. This simplifies the PLL circuitry by eliminating the need for a separate HET XTAL for each band.

# CIRCUIT DESCRIPTION

Frequency organization of the PLL circuit is shown in Figure 1, the circuit diagram in Figure 2, and frequency organization in other circuits is summarized in Table 4. Please refer to Figure 1 when reading the following description on PLL circuit operation. MIX (3), a double balanced mixer, mixes the CAR output with the VFO output. MIX (2) which operates in 18 MHz bands and above, mixes either 10 MHz, in the 14 and 18 MHz bands, or 20 MHz, in the 21, 24.5, and 28 MHz bands, with the output of MIX (3) to generate the appropriate frequency needed for each band, as shown in Table 4. This is mixed with the VCO output for each band by MIX (1) to a frequency given in Table 4, which is then routed through LPF (1), amplified, and wave-shaped to a digital signal. A programmable divider divides this signal into a 500 kHz output. This programmable divider is preset, as shown in Table 4, by the BCD signal which is counter-generated from information coming from the band switch. The phase comparator used is a Motorola MC4044P. The loop filter is made of completely external components to minimize spurious radiation. Six VCOs cover all bands. If the PLL unlocks for any reason, it will be detected from the phase comparator output. This will turn off the VCO output to prevent spurious radiation and, at the same time, the digital display will be blanked to inform the operator of unlock status.

BAND	RX, Tx frequency (MHz)	VCO (MHz)	MIX (1) input (MHz)	MIX (1) output (MHz)	Division ratio	DCBA
1.5	1.5 ~2.0	10.33 ~10.88	14.33 ~14.83	4.0	1/8	1 0 0 0
3.5	3.5 ~4.0	12.33 ~12.83	14.33 ~14.83	2.0	1/4	1 1 0 0
7	7.0 ~7.5	15.83 ~16.33	14.33 ~14.83	1.5	1/3	1 1 0 1
10	10.0 ~10.5	18.83 ~19.33	14.33 ~14.83	4.5	1/9	0 1 1 1
14	14.0 ~14.5	22.83 ~23.33	24.33 ~24.83	1.5	1/3	1 1 0 1
18	18.0 ~18.5	26.83 ~27.33	24.33 ~24.83	2.5	1/5	1 0 1 1
21	21.0 ~21.5	29.83 ~30.33	34.33 ~34.83	4.5	1/9	0 1 1 1
24.5	24.5 ~25.0	33.33 ~33.83	34.33 ~34.83	1.0	1/2	1 1 1 0
28	28.0 ~28.5	36.83 ~37.33	"	2.5	1/5	1 0 1 1
28.5	28.5 ~29.0	37.33 ~37.83	"	3.0	1/6	1 0 1 0
29	29.0 ~29.5	37.83 ~38.33	"	3.5	1/7	1 0 0 1
29.5	29.5 ~30.0	38.33 ~38.83	"	4.0	1/8	1 0 0 0

Table 6. Frequency chart

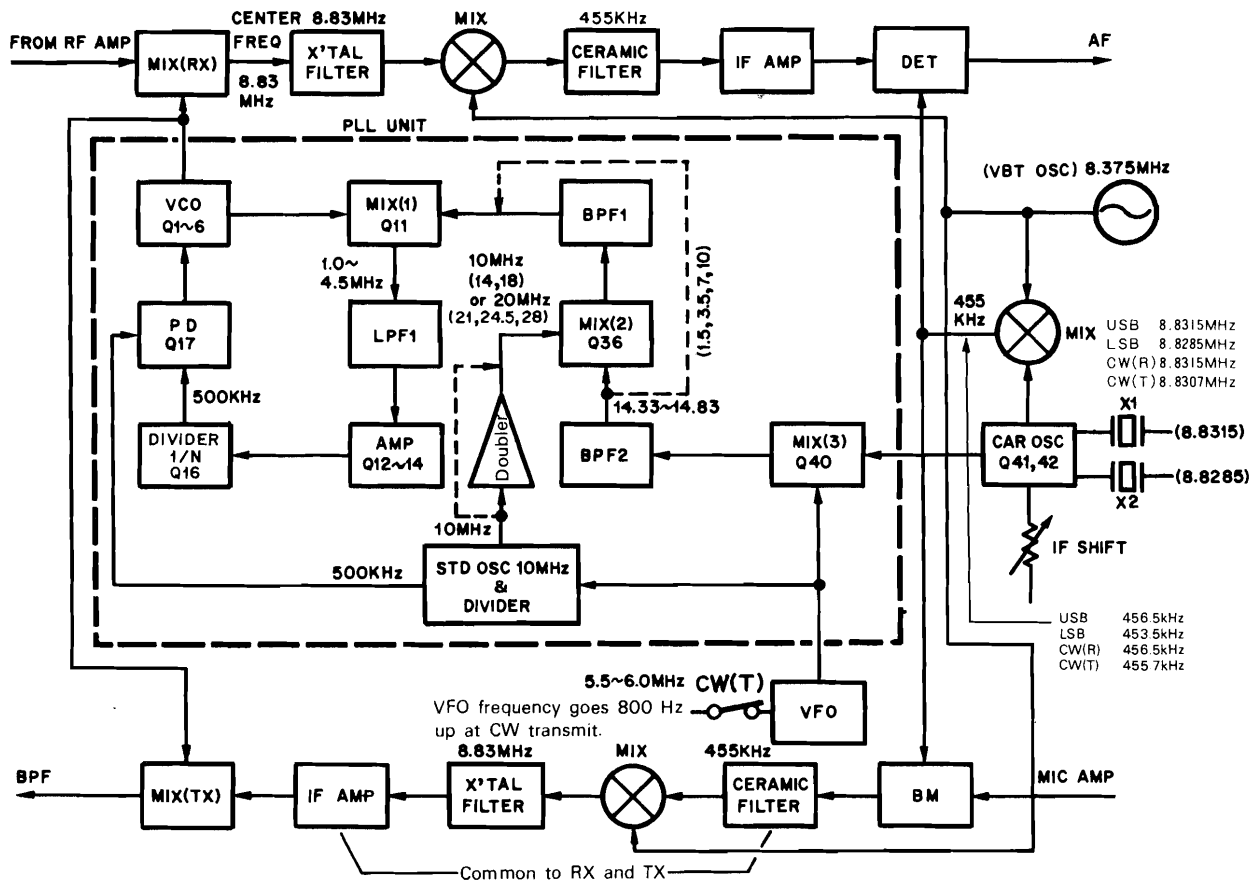


Fig. 1 TS-830 Frequency configuration



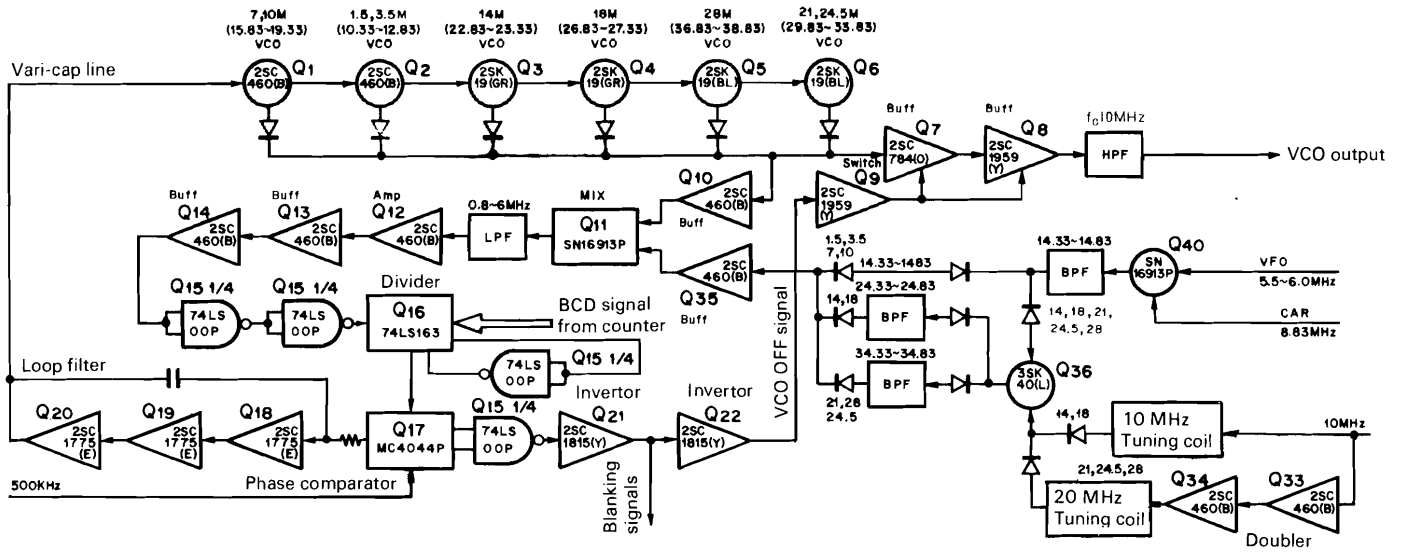


Fig. 2 TS-830 PLL circuit configuration

## COUNTER

This counts the 500 kHz to 1 MHz signal which the PLL unit generates by mixing the VFO output with 5 MHz (halved from the 10 MHz reference frequency). Gate, latch, and preset pulses are generated from a 10 Hz pulse generated by dividing 1 kHz, supplied from the PLL, by 100.

BAND	100K	1 M	10M	DCBA	0.5	BAND	100K	1 M	10M	DCBA	0.5
1.5	0	1	0	1 0 0 0	H	21	5	0	2	0 1 1 1	L
3.5	0	3	0	1 1 0 0	H	24.5	0	4	2	1 1 1 0	H
7	5	6	0	1 1 0 1	L	28	5	7	2	1 0 1 1	L
10	5	9	0	0 1 1 1	L	28.5	0	8	2	1 0 1 0	H
14	5	3	1	1 1 0 1	L	29	5	8	2	1 0 0 1	L
18	5	7	1	1 0 1 1	L	29.5	0	9	2	1 0 0 0	H

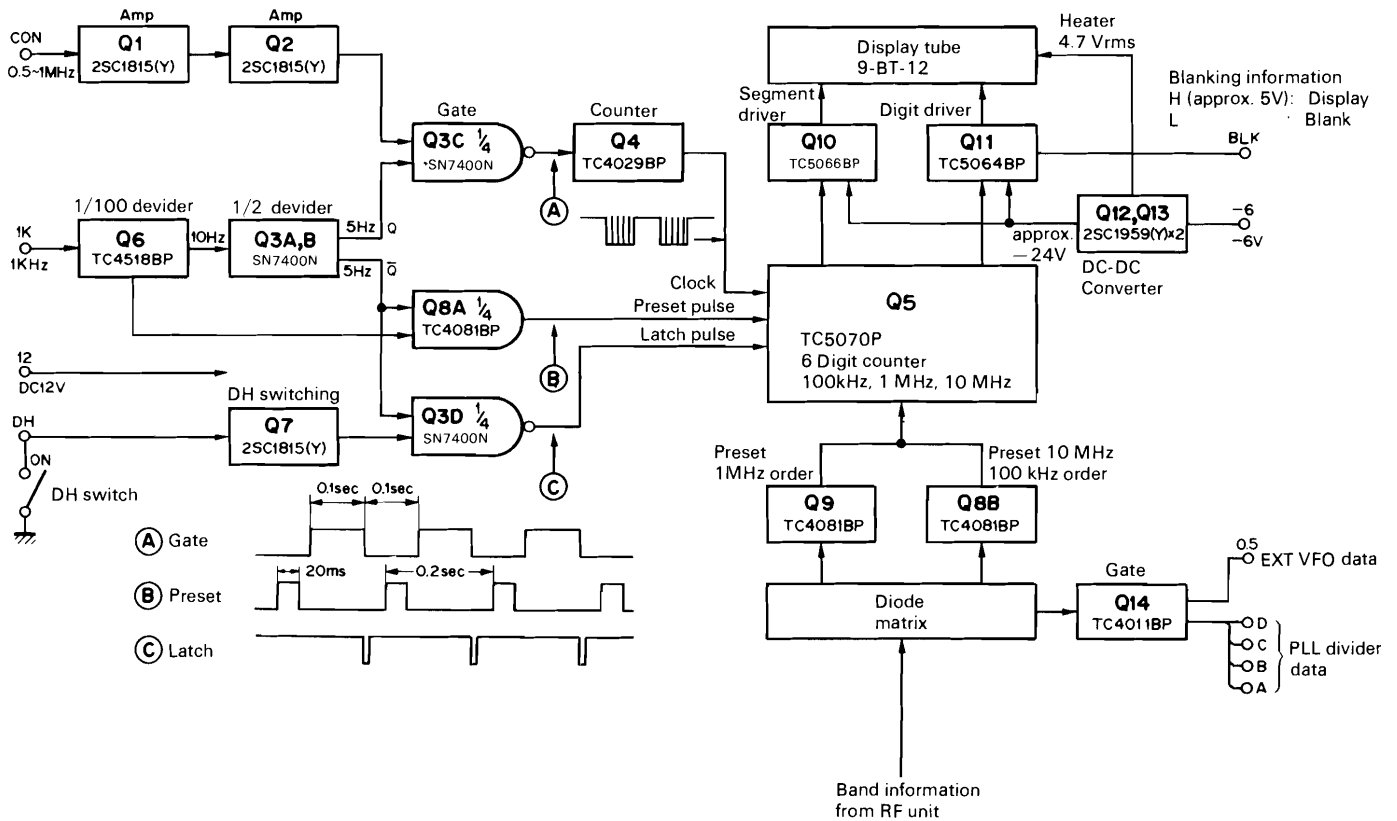


Fig. 3 Counter unit block diagram

# CIRCUIT DESCRIPTION

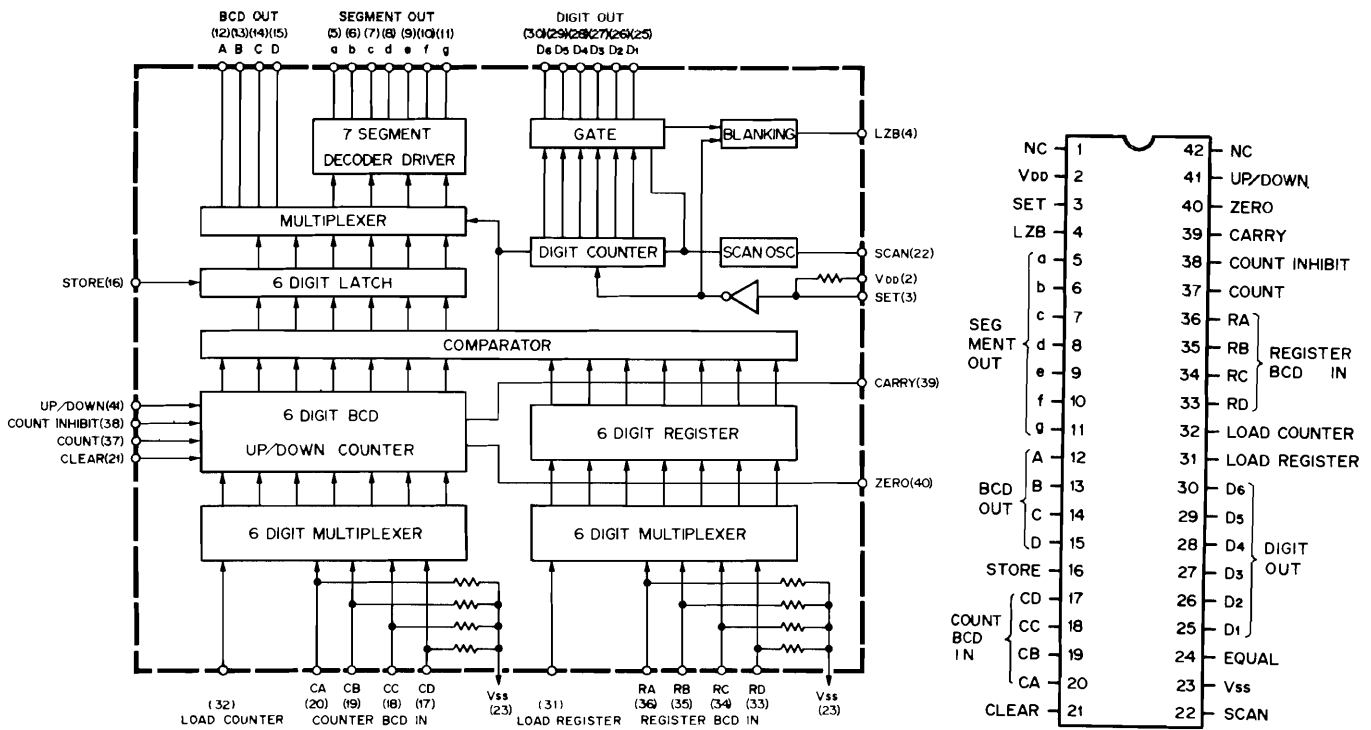


Fig. 4 TC5070P (Counter unit, Q5)

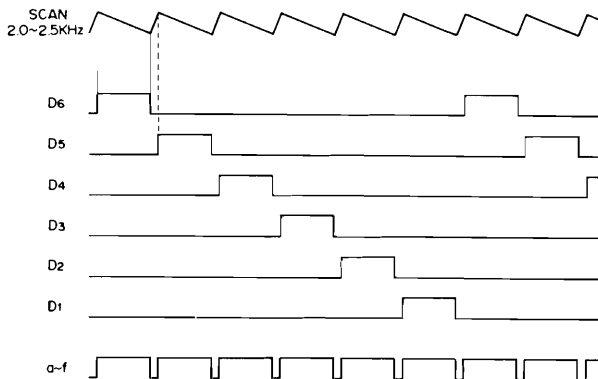
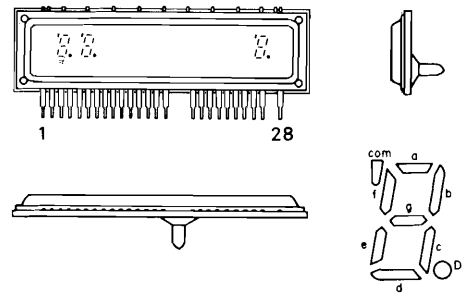


Fig. 5 TC5070P timing chart



PIN NO	1	2	3	4	5	6	7	8	9	10	11	12	13	14
CONNECTION	F	N <sub>C</sub>	G <sub>9</sub>	N <sub>C</sub>	N <sub>C</sub>	G <sub>8</sub>	g	f	G <sub>7</sub>	e	d	G <sub>6</sub>	N <sub>C</sub>	N <sub>C</sub>
	15	16	17	18	19	20	21	22	23	24	25	26	27	28
	G <sub>5</sub>	N <sub>P</sub>	N <sub>P</sub>	G <sub>4</sub>	D <sub>P</sub>	G <sub>3</sub>	c	b	G <sub>2</sub>	a	COM	G <sub>1</sub>	N <sub>P</sub>	F

Fig. 6 Indicating tube 9-BT-12

Q5 (TC5070P) is a presettable, 6-digit BCD counter which incorporates a 6-digit latch, 6-digit dynamic drive digital counter, and 7-segment decoder/driver. Band information supplied from the RF unit is applied to a diode matrix to preset the 100 kHz, 1 MHz, and 10 MHz digits. Preset values are given in Figure 3. For instance to preset 14.000 MHz, with a 500 kHz counter input signal, 10 MHz value is preset to 1, 1 MHz to 3, and 100 kHz to 5, the 500 kHz counter input signal subtracted from 14.000 MHz. (If no counter input signal were present, 13.500 MHz would be displayed.) Q5 supplies the display tube drivers with 7-segment information and dynamic drive control signals to light the fluorescent display tube.

In the counter unit, a diode matrix generates frequency division information and supplies the PLL unit with this information. If the PLL unlocks, a BLK (Blanking Low) signal will be applied to the digit drive IC (Q11) to blank the fluorescent display tube. Normally, five high-order digits are displayed. DH (digital hold) locks the display from changing. Digital hold is accomplished by presetting the latch pulse at Low level.

## CAR OSCILLATOR

The CAR oscillator is composed of an oscillator and two quartz crystals. The output frequency in each mode is given in Figure 1. During reception, this frequency can be varied by the IF shift.

## VFO

The output frequency is 5.5~6.0 MHz. During CW transmission, the frequency will be shifted 800 Hz higher than the reception frequency. Therefore, real operating frequencies will always be displayed.

## CIRCUIT FEATURES

### 1. Optional filters available

The TS-830S is equipped with 2.7 kHz filters in both the 8.83 MHz and 455 kHz IF's. Narrow filters are separately available for both 8.83 MHz and 455 kHz.

IF jumper pins	8.83 MHz filter	455 kHz filter
CW1	STD (YK88S1)	STD (CFJ455K5)
CW2	OP (option)	STD (CFJ455K5)
CW3	STD (YK-88S1)	OP (option)
CW4	OP (option)	OP (option)
6 dB bandwidth	YK-88S1 = 2.7kHz OP (YK-88C) = 500Hz OP (YK-88CN) = 270Hz	CFJ455K5 = 2.7kHz OP (YG-455C) = 500Hz OP (YG-455CN) = 250Hz

**Table 7. STD and OP filter combinations**

Item	Rating
Center frequency $f_0$	8830.7 kHz
Center frequency deviation	$f_0 \pm 150\text{Hz}$ at 6 dB
6 dB bandwidth	$\pm 250\text{ Hz}$ or more
60 dB bandwidth	$\pm 900\text{ Hz}$ or less
Ripple	2 dB or less
Loss	6 dB $\pm$ 2 dB
Guaranteed attenuation	80 dB or more within $f_0 \pm 2\text{ kHz}$ to $\pm 1\text{ MHz}$
Input and output impedance	600 $\Omega$ // 15 pF

**Table 8. CW Crystal filter (L71-0211-05)  
YK-88C (Option)**

Item	Rating
Center frequency $f_0$	8830.7 kHz
Center frequency deviation	$f_0 \pm 50\text{ Hz}$ at 6 dB
6 dB bandwidth	$\pm 125\text{ Hz}$ or more
60 dB bandwidth	$\pm 600\text{ Hz}$ or less
Ripple	2 dB or less
Loss	8 dB $\pm$ 2 dB
Guaranteed attenuation	80 dB or more within $f_0 \pm 2\text{ kHz}$ to $\pm 1\text{ MHz}$
Input and output impedance	600 $\Omega$ // 15 pF

**Table 9. CW Crystal filter (L71-0221-05)  
YK-88CN (Option)**

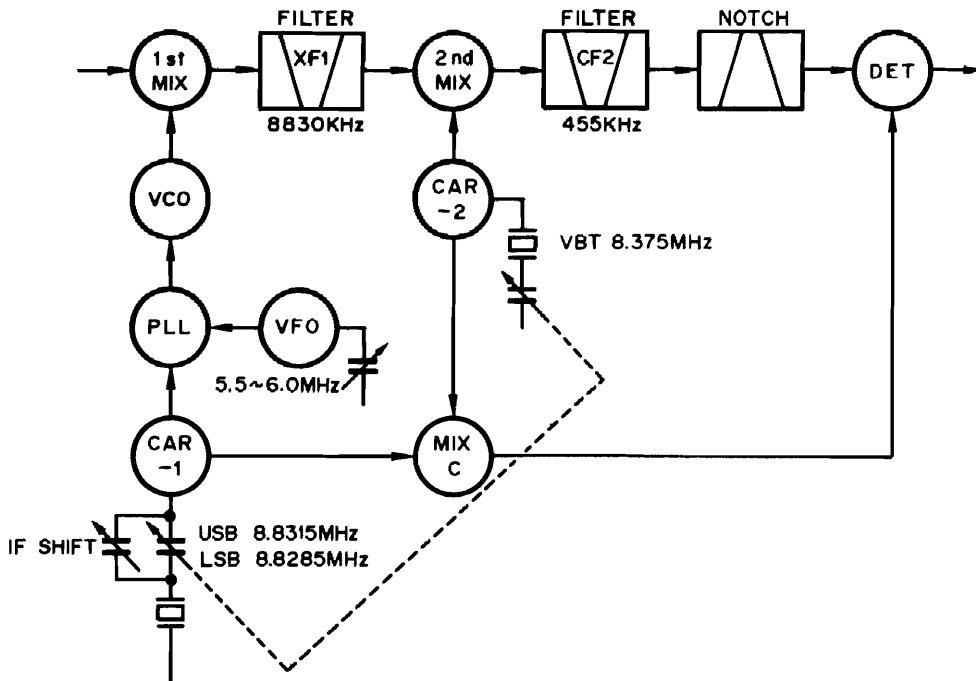
Item	Rating
Center frequency $f_0$	455.7 kHz
Center frequency deviation	$f_0 \pm 50\text{ Hz}$ at 6 dB
6 dB bandwidth	$\pm 250\text{ Hz}$ or more
60 dB bandwidth	$\pm 425\text{ Hz}$ or less
Ripple	2 dB or less
Loss	6 dB or less
Guaranteed attenuation	80 dB or more at 100 Hz to 455.1 kHz and 456.3 kHz to 2 MHz
Input and output impedance	2 k $\Omega$ // 15 pF

**Table 10. CW Crystal filter (L71-0206-05)  
YG-455C (Option)**

Item	Rating
Center frequency $f_0$	455.7 kHz
Center frequency deviation	$f_0 \pm 50\text{ Hz}$ at 6 dB
6 dB bandwidth	$\pm 125\text{ Hz}$ or more
60 dB bandwidth	$\pm 250\text{ Hz}$ or less
Ripple	2 dB or less
Loss	6dB or less
Guaranteed attenuation	80 dB or more at 100 Hz to 455.3 kHz and 456.1 kHz to 2 MHz
Input and output impedance	2 k $\Omega$ // 15 pF

**Table 11. CW Crystal filter (L71-0207-05)  
YG-455CN**

# CIRCUIT DESCRIPTION



BAND	VCO MHz
1.5	10.33 ~ 10.83
3.5	12.33 ~ 12.83
7	15.83 ~ 16.33
10	18.83 ~ 19.33
14	22.83 ~ 23.33
18	26.83 ~ 27.33
21	29.83 ~ 30.33
24.5	33.33 ~ 33.83
28	36.83 ~ 37.33
28.5	37.33 ~ 37.83
29	37.83 ~ 38.33
29.5	38.33 ~ 38.83

Fig. 7 Frequency configuration

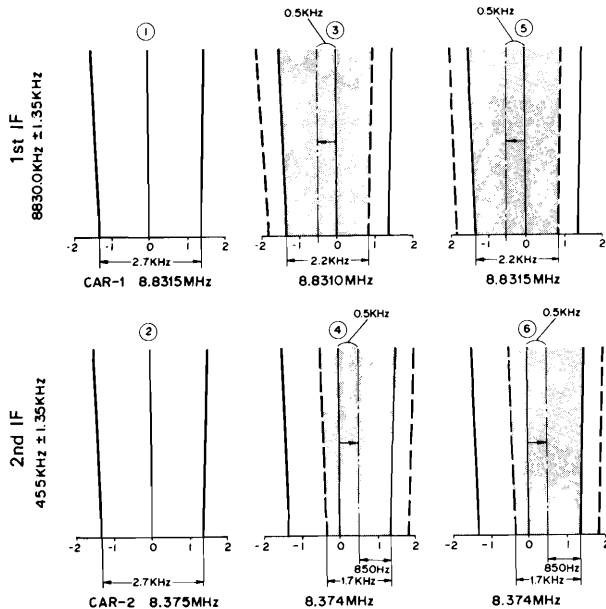


Fig. 8 VBT, IF SHIFT

## 2. VBT and IF SHIFT

VBT (variable bandwidth tuning) allows varying the bandwidth, operation of which is determined by the 8.83 MHz and 455 kHz filters and by changing the output frequencies of CAR-1 and CAR-2 simultaneously with the VBT control. Frequency organization of the VBT and IF SHIFT is shown in Figure 7. Assuming that a signal centered at 14.0015 MHz is received without IF shift or VBT, the VFO output frequency is 5.5015 MHz, CAR-1 8831.5 kHz, and the VCO output applied to the first mixer is 22.8315 MHz.

The mixer converts this to a signal whose center frequency is 8.830 MHz (22.8315 MHz - 14.0015 MHz = 8.830 MHz). The signal frequency is then converted to 455 mHz by the second mixer. To help understand VBT operation, assume the composite bandwidth determined by filters XF1 and CF2 is 2.7 kHz in the normal (unshifted) state of CAR-1 and -2. Frequency organization to obtain a specific bandwidth and IF SHIFT is described below.

### Example 1 (no IF shift)

{ Bandwidth 1.7 kHz }  
{ IF SHIFT 0 kHz }

When the CAR-2 frequency is reduced by 1 kHz using the VBT control and a signal centered at 14.0015 MHz is received, the CAR-1 and -2 frequencies are as follows.

CAR-1 8831.0 kHz (= 8831.5 kHz - 0.5 kHz\*)  
CAR-2 8374.0 kHz (VBT control)

\* The system is designed so that only half the amount of frequency shift applied to CAR-2 is applied to CAR-1. Assume the received signal has a frequency spectrum extending over 14.0015 MHz ± 1.35 kHz. Since CAR-1 output is 8831.0 kHz, the VCO output frequency is 22.8310 MHz and, therefore, the frequency of the first IF signal is 8829.5 kHz ± 1.35 kHz due to a shift of -500 Hz. (22831.0 kHz - 14001.5 kHz = 8829.5 kHz). Since the frequency characteristic of the first IF filter is 8.830 MHz ± 1.35 kHz as noted above, frequency components are cut in the lower side band by 500 Hz more than in the normal state, as illustrated in Fig. 8 (3). The second intermediate frequency generated in the second mixer is 455.5 kHz ± 1.35 kHz.

$(8829.5 \text{ kHz (No. 1 IF)} - 8374.0 \text{ kHz (CAR-2)}) = 455.5 \text{ kHz}$   
 Thus the second IF signal is shifted by +500 Hz, and as a result the upper-side frequency components are cut by 500 Hz, as illustrated in (4). The frequency spectrum of the signal which has passed the second IF stage is  $455.5 \text{ kHz} \pm 850 \text{ Hz}$  and the bandwidth is 1.7 kHz. If we convert the signal frequency to an equivalent one at the ANT input, we obtain  $14.0015 \text{ MHz} \pm 850 \text{ Hz}$ . In this case IF SHIFT operation is not performed.

### Example 2

{ Bandwidth 1.7 kHz  
 IF SHIFT 500 Hz (positive shift) }

When the frequency of CAR-2 is lowered by 1 kHz with the VBT control and that of CAR-1 raised by 500 Hz with the SHIFT control, the resulting frequencies of CAR-2 and -1 are

CAR-1 8831.5 kHz (=  $8831.5 \text{ kHz} - 0.5 \text{ kHz} * 1 + 0.5 \text{ kHz} * 2$ )

CAR-2 8374.0 kHz

- \*1 Half the amount of frequency varied by VBT
- \*2 The amount of frequency rise with IF SHIFT

Let us examine the frequency spectrum of the ANT input signal from the second IF component in Example 1. You will recall that the center frequency of the second IF signal component is 455.5 kHz and the upper limit  $455.5 \text{ kHz} + 850 \text{ Hz}$ .

The signal is  $455.5 \text{ kHz} + 8374.0 \text{ kHz} = 8829.5 \text{ kHz}$  in the first IF and the lower limit  $8829.5 \text{ kHz} - 850 \text{ Hz}$ . As a result, signal components which have passed an 8830 kHz filter and a 455 kHz filter are the same as in Example 1. But the VCO output is 22.8315 MHz because CAR-1 which was 8831.0 kHz in Example 1 is 8831.5 kHz in Example 2. Since the converted equivalent frequency range at the first IF is  $8829.5 \text{ kHz} \pm 850 \text{ Hz}$ , its equivalent at the ANT input is  $14.002 \text{ MHz} \pm 850 \text{ Hz}$ .

$(22.8315 \text{ MHz} - 8.8295 \text{ MHz}) = 14.002 \text{ MHz}$

This means that a signal 1.7 kHz in bandwidth is received with a shift of +500 Hz. In other words, the filter characteristics have been changed appropriately.

As you may have noted in Examples 1 and 2, the VBT and IF SHIFT controls operate separately. Therefore, it is possible to control the bandwidth alone while keeping the IF SHIFT unchanged, or control IF SHIFT while keeping the bandwidth unchanged.

### 3. NOTCH [in IF unit (X48-1290-00)]

This is a bridged-T filter consisting of L, C, and R components. The notch is provided in the 455 kHz IF. Normally, the width of the null would be broad at 455 kHz. Actually a sharp notch is provided by adding an active circuit which applies positive feedback to raise the Q. Q5 and Q6 (2SC1815Y) are a Q-multiplier. Q7 (2SC1815Y) is a buffer amplifier.

### 4. Speech processor [in IF unit (X48-1290-00)]

This speech processor is an RF clipper. The receiver uses two intermediate frequencies and two filters for VBT. In the transmitter, an SSB signal is generated at 455 kHz, is converted to 8830 kHz, and passed through an SSB 8.83 MHz filter after frequency conversion. This configuration is con-

venient for installing RF clippers between the stages. The 455 kHz SSB signal is clipped and then converted to an 8.83 MHz signal, and then routed through an 8.83 MHz SSB filter to remove splatter components generated during clipping. Q24 (2SC1815Y) is a processor amplifier, Q26 (TA7302P) a limiting amplifier, Q27 (3SK73GR) a control amplifier, and Q25 (2SC1815Y) and Q37 (2SA1015Y) compose a compression meter amplifier. The compression meter reads the mean compression level.

### 5. Final-stage RF NFB

Negative feedback is applied to the driver from the final output stage via C6, a 3PF, 3KV capacitor to reduce intermodulation distortion.

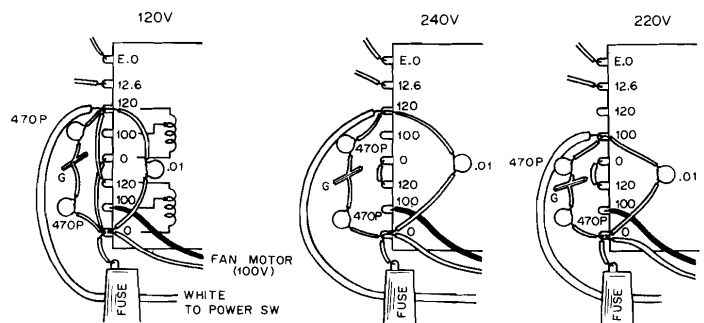
### 6. RIT/XIT Operations

In addition to the conventional RIT, the transmission frequency can be varied with the XIT control.

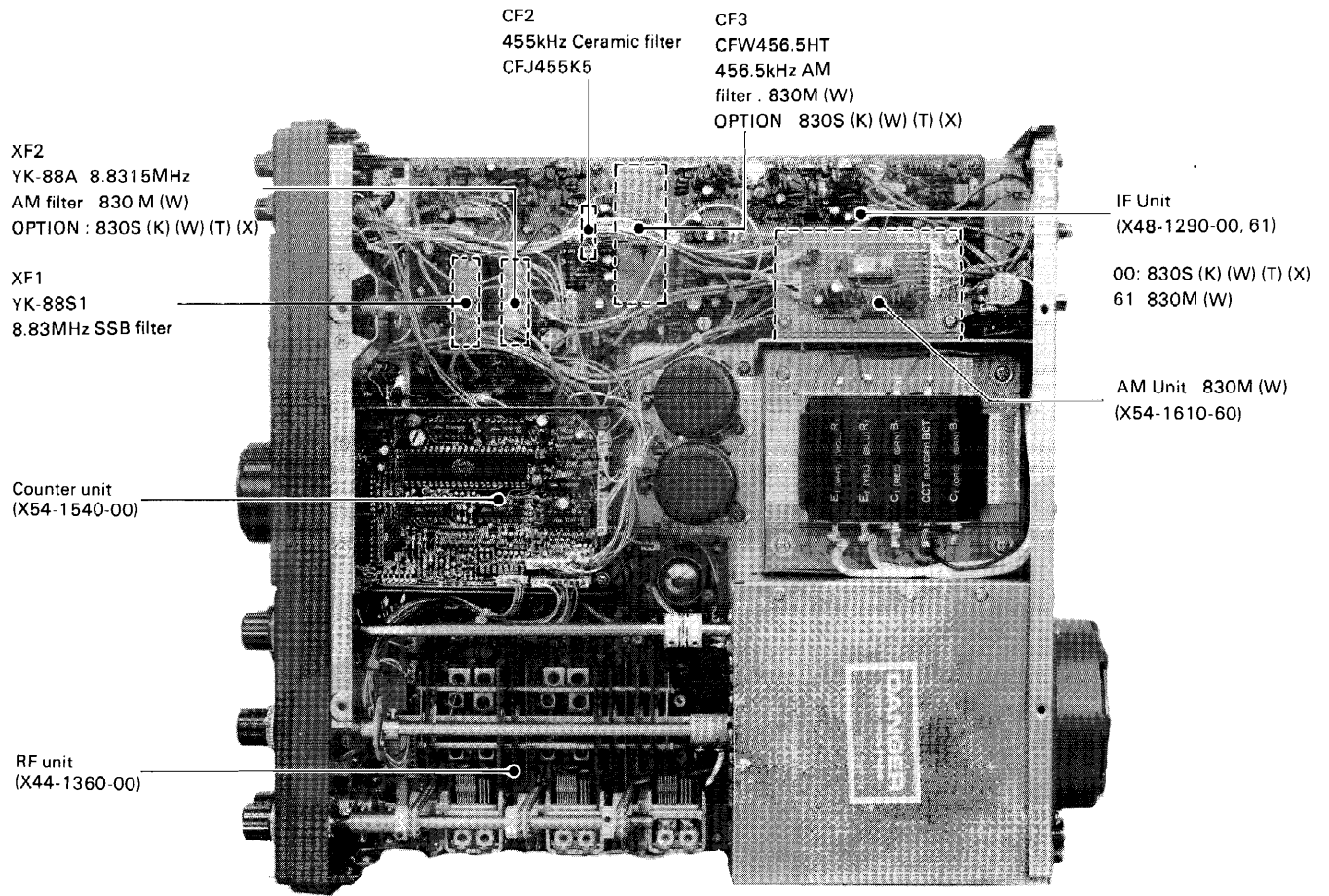
### TS-830S (K) AC Voltage conversion

To operate the TS-830S (K) on 240V AC, the power transformer split primaries must be rewired from parallel to series connection.

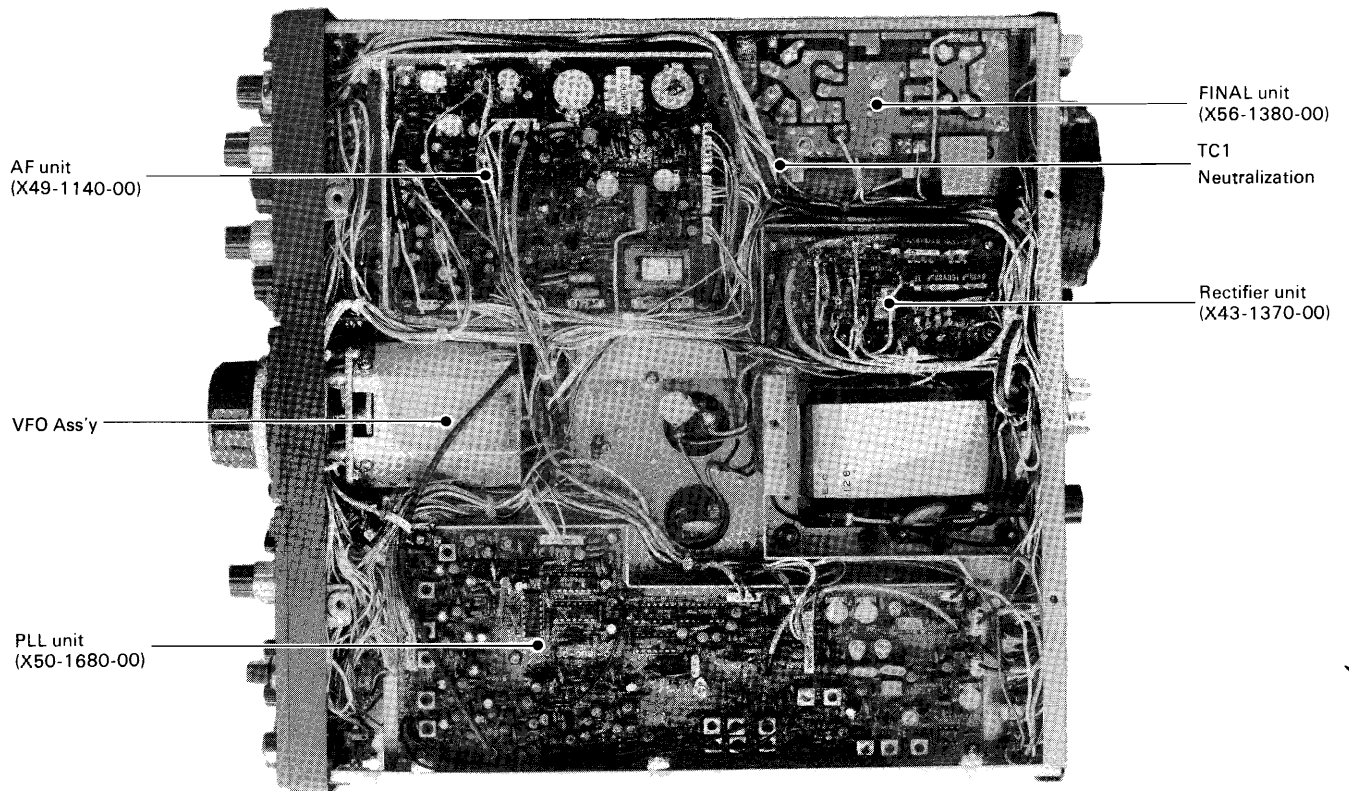
1. Unplug the AC power cable.
2. Remove the bottom cover.
3. Remove the jumper wires between the two  $\phi$  terminals and two 120 terminals on the bottom of the power transformer.
4. Connect the adjacent 120 and  $\phi$  terminals at the middle of the transformer. This will provide 240V AC operation. For 220V AC operation, change the wires from 120 to 100 winding.
5. Change the AC fuse from 6A to 4A. Tag the power cord at the back of the radio to indicate that the transformer is strapped for 240V AC, and the power fuse should be 4A, and not 6A.
6. Replace the bottom cover and reconnect power to verify your work.



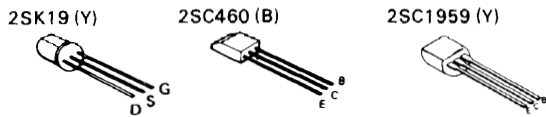
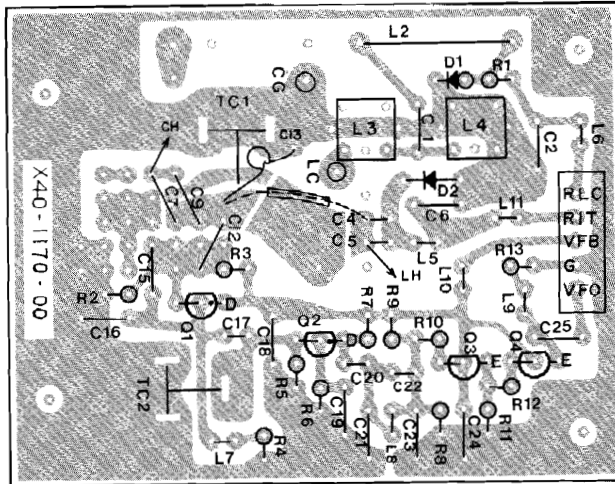
# INSIDE VIEWS



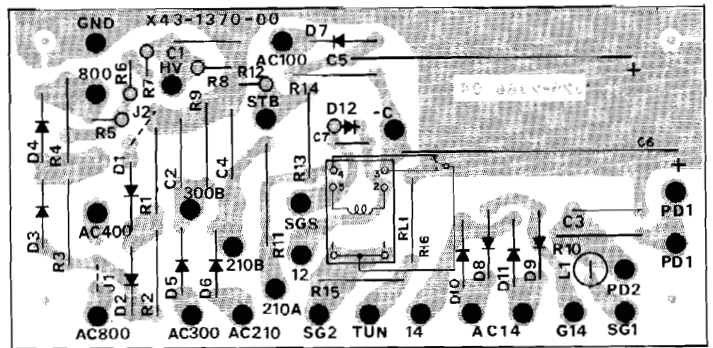
[830M type is shown.]



▼ VFO UNIT (X40-1170-00)



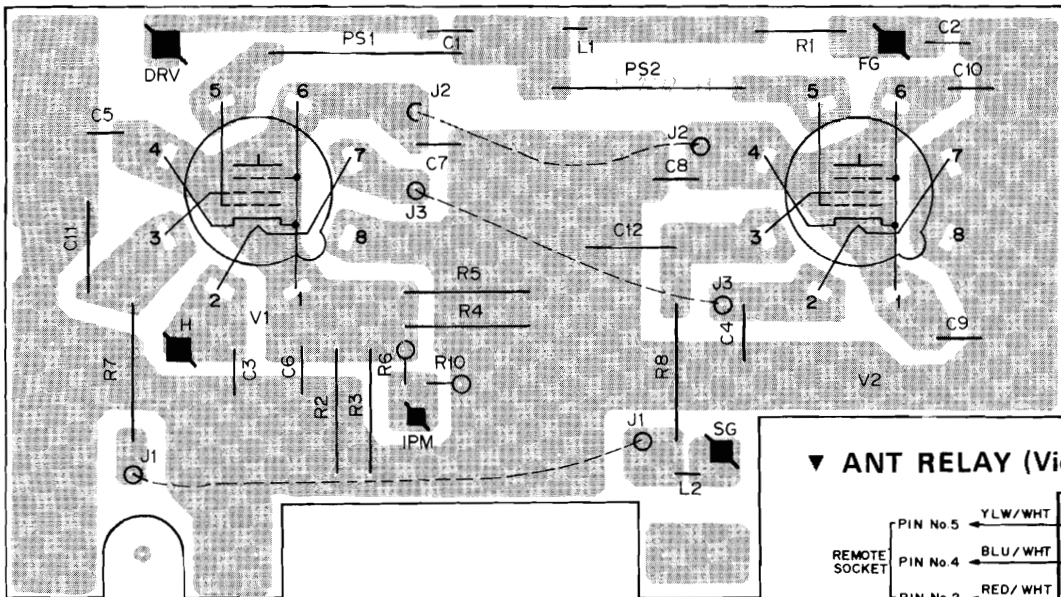
▼ RECTIFIER UNIT (X43-1370-00)



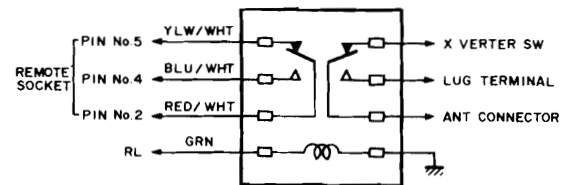
D1~6 V08J D7 V06E D8~11 V03C D12 1S1555

O1,2 2SK19(Y) O3 2SC460(B) or 2SC1675(L) O4 2SC1959(Y)  
D1 1S2588 D2 1SV53A

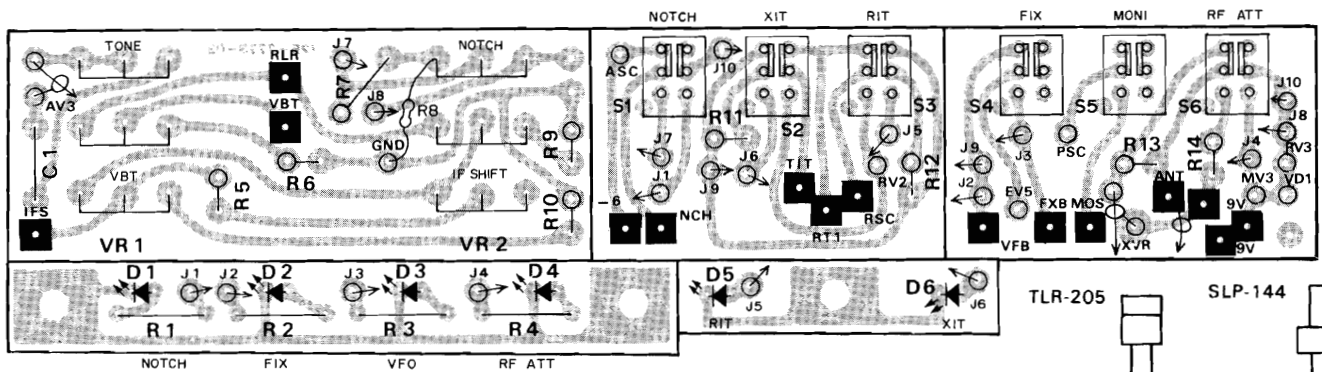
▼ FINAL UNIT (X56-1380-00) (View from foil side)



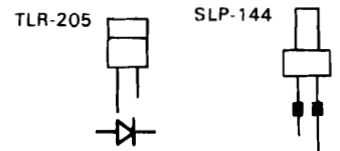
▼ ANT RELAY (View from terminal side)



▼ SWITCH BOARD (J25-2773-03)



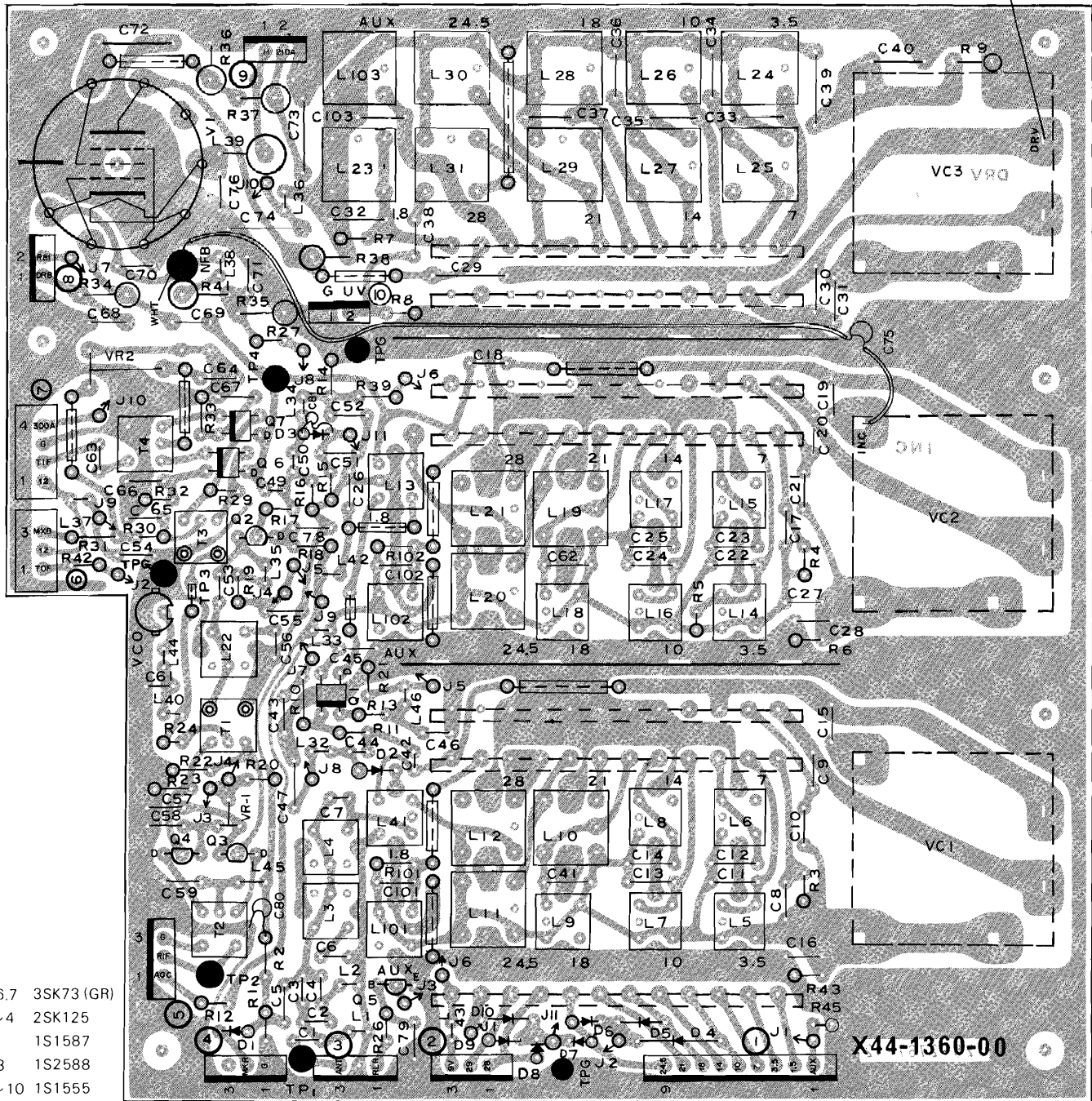
D1~4 TLR-205 D5,6 SLP-144





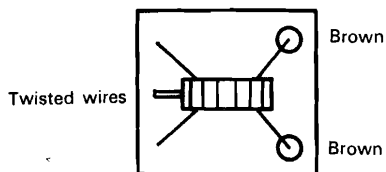
# TS-830S, M PC BOARD VIEWS

## ▼ RF UNIT (X44-1360-00)

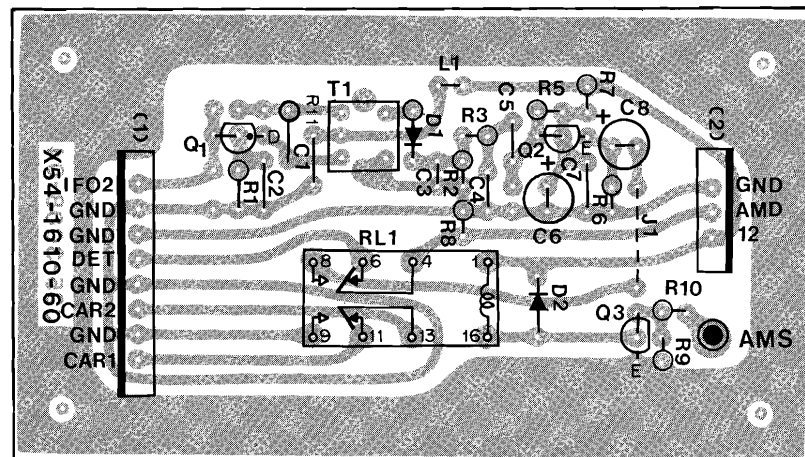


## ▼ AM UNIT (X54-1610-60): TS-830 M (W)

< Attachment method of T1, T2 >

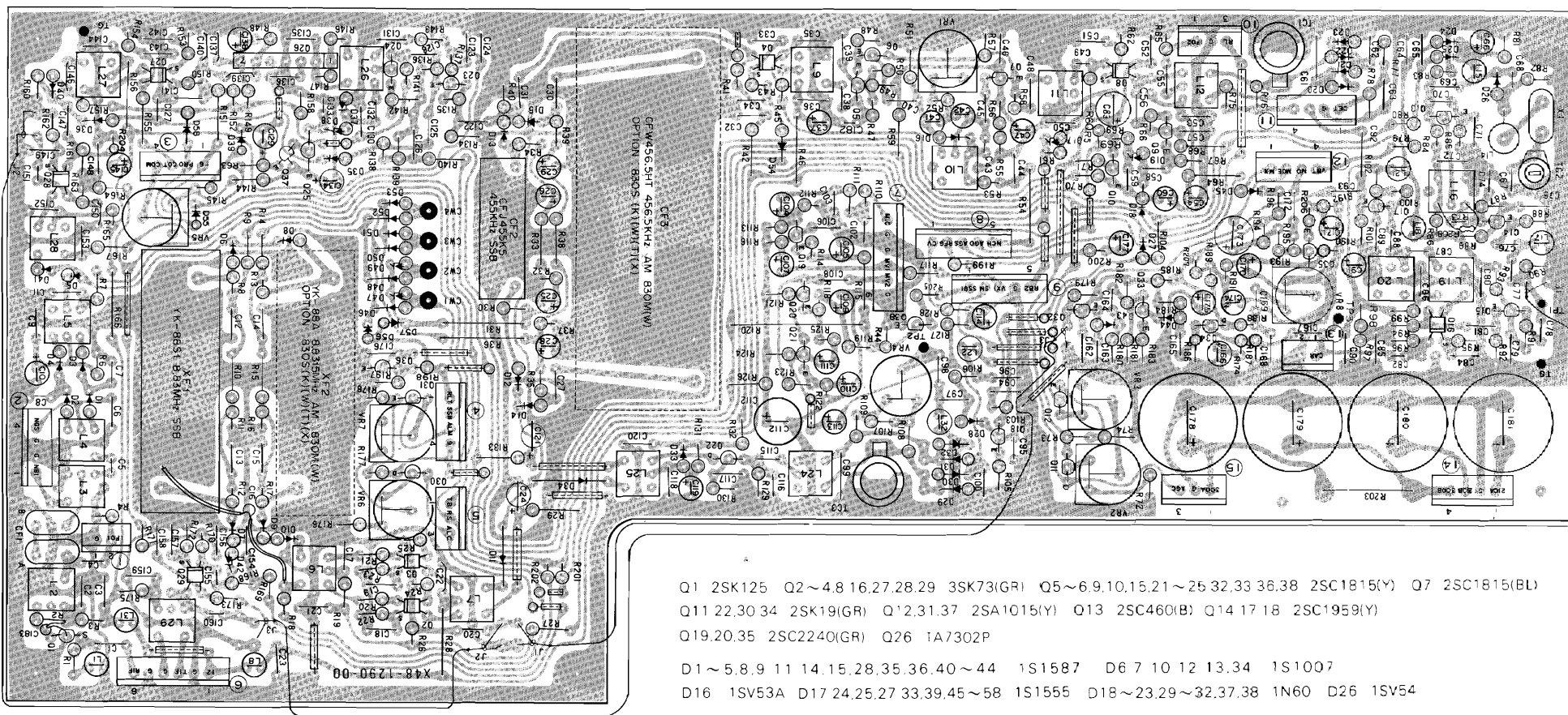


- Q1: 2SK19 (GR)    Q2, 3: 2SC945 (Q)
- D1: 1N60    D2: 1S1555



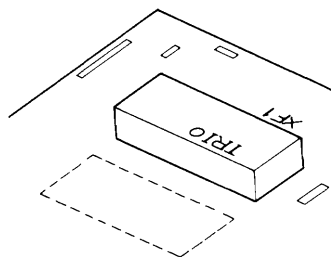


▼ IF UNIT (X48-1290-00) : 830S (K) (W) (T) (X)  
 (X48-1290-61) : 830M (W)

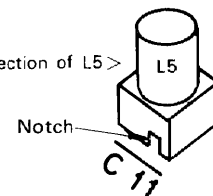


Q1 2SK125 Q2~4.8.16.27.28.29 3SK73(GR) Q5~6.9.10.15.21~25.32.33.36.38 2SC1815(Y) Q7 2SC1815(BL)  
 Q11.22.30.34 2SK19(GR) Q'2.31.37 2SA1015(Y) Q13 2SC460(B) Q14.17.18 2SC1959(Y)  
 Q19.20.35 2SC2240(GR) Q26 1A7302P  
 D1~5.8.9.11.14.15.28.35.36.40~44 1S1587 D6.7.10.12.13.34 1S1007  
 D16 1SV53A D17.24.25.27.33.39.45~58 1S1555 D18~23.29~32.37.38 1N60 D26 1SV54

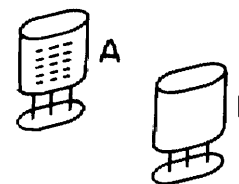
< Attachment direction of XF1 >



< Attachment direction of L5 >

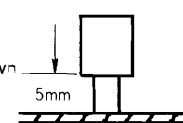


< Attachment method of CF1 >  
 Attach them so that the lettered sides face each other (For CF1 supplied as a pair, attach 1 to side A and 2 to side B.)

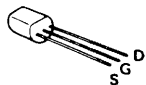


< Attachment method of C41, 42 and 101 >

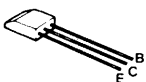
Should be installed as shown at right.



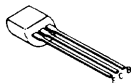
2SK125



2SC460(B)



2SA1015(Y)  
 2SC1815(Y),(BL)  
 2SC1959(Y)  
 2SC2240(GR)



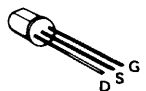
TA7302P



3SK73(GR)



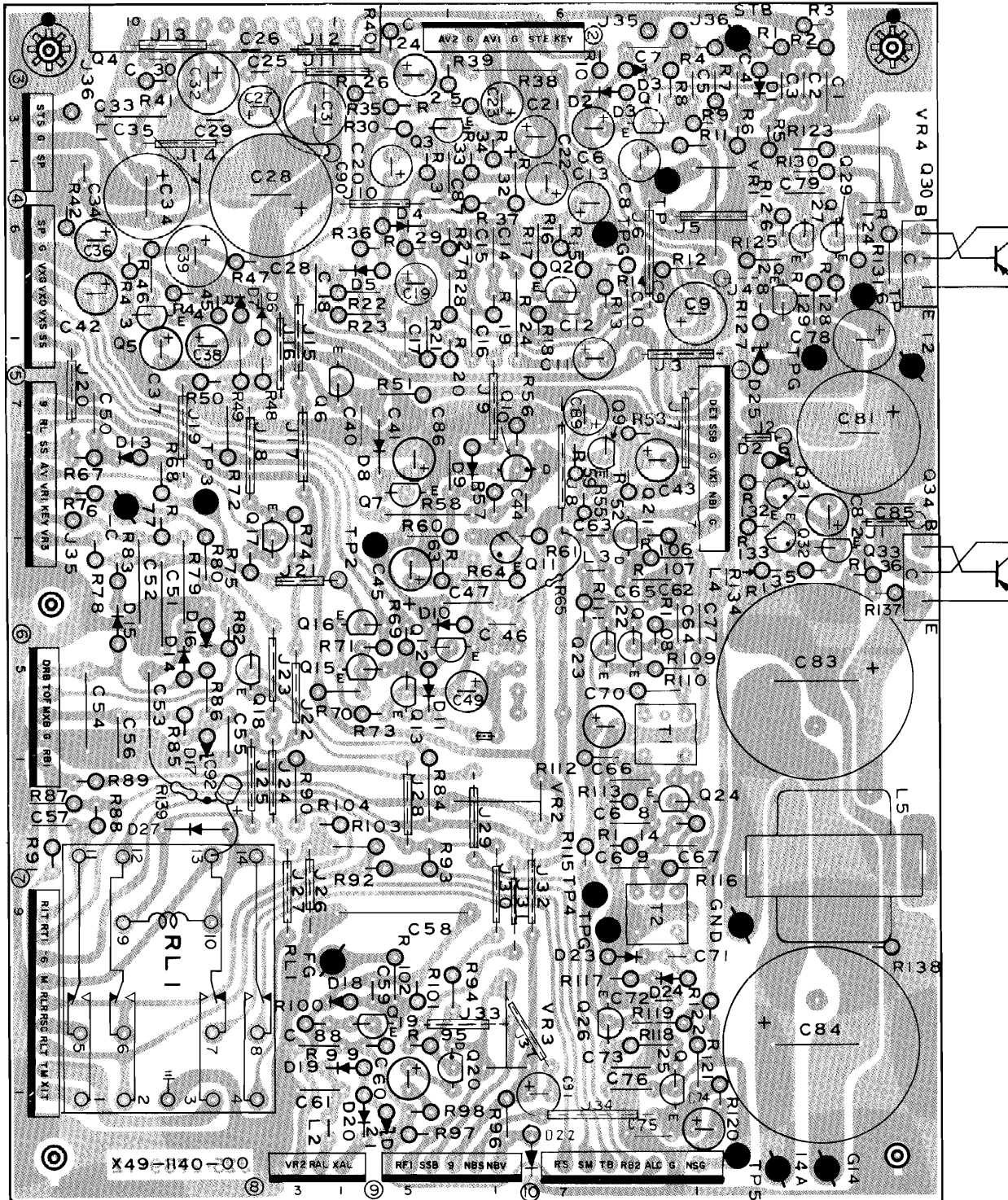
2SK19(GR)



13

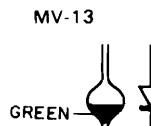
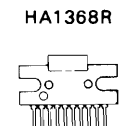
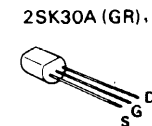
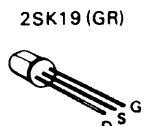
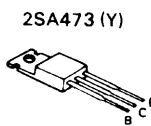
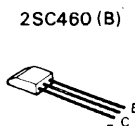
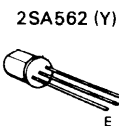
# TS-830S, M PC BOARD VIEW

▼ AF UNIT (X49-1140-00)



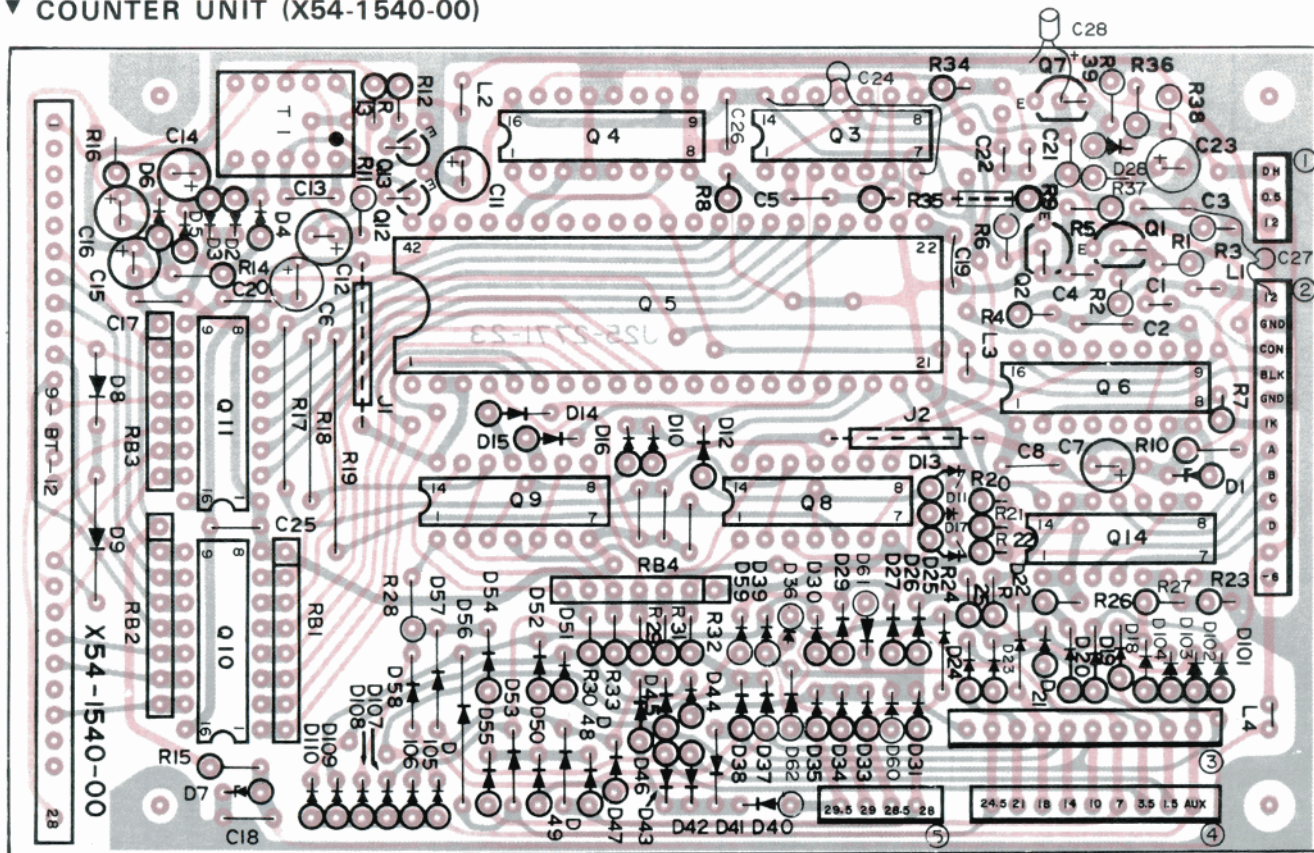
Q1,5,6,7,11,12,16,18,26~29,31,32 2SC945(Q) or 2SC1815(Y) Q2,3 2SC2240(GR) Q4 HA1368R Q9,13,33 2SA1015(Y) Q10 2SK30A(GR)  
 Q15,25 2SC1815(GR) Q17 2SA562(Y) Q19 2SC1515(K) Q20 2SK30A(O) Q21 2SK19(GR) Q22~24 2SC460(B) Q30,34 2SA473(Y)  
 D1,2,4~10,13,16,18,27 1S1555 D3,17,21 WZ-090 D11,23,24 1N60 D14,15,19,20 VO6B D22 MV-13 D25 WZ-061 D26 XZ-090

2SA1015 (Y)  
 2SC945 (Q)  
 2SC1515 (K)  
 2SC1815 (GR), (Y)  
 2SC1959 (Y)  
 2SC2240 (GR)

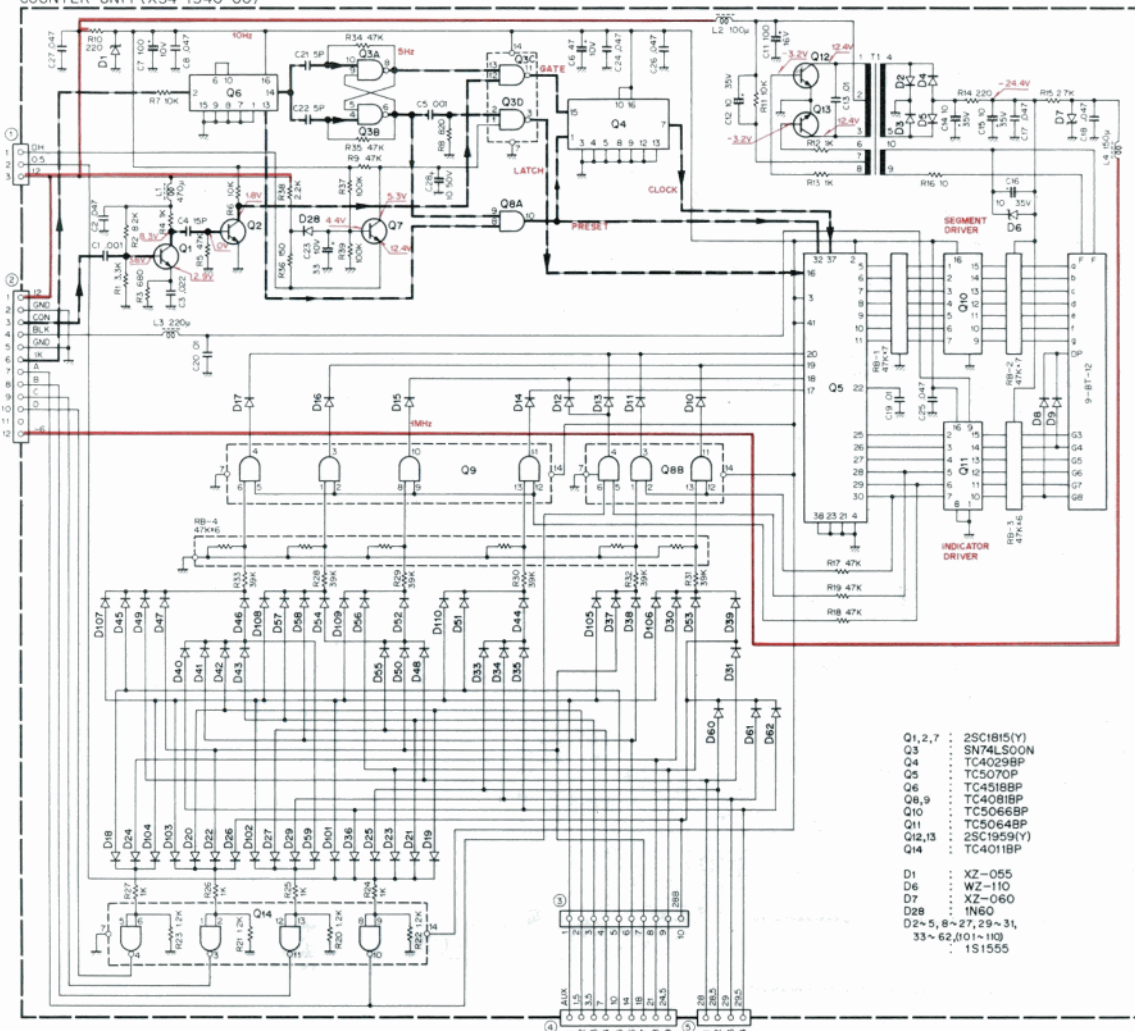




▼ COUNTER UNIT (X54-1540-00)

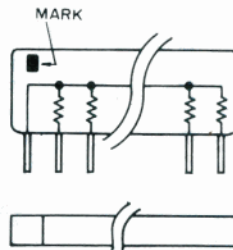


COUNTER UNIT (X54-1540-00)



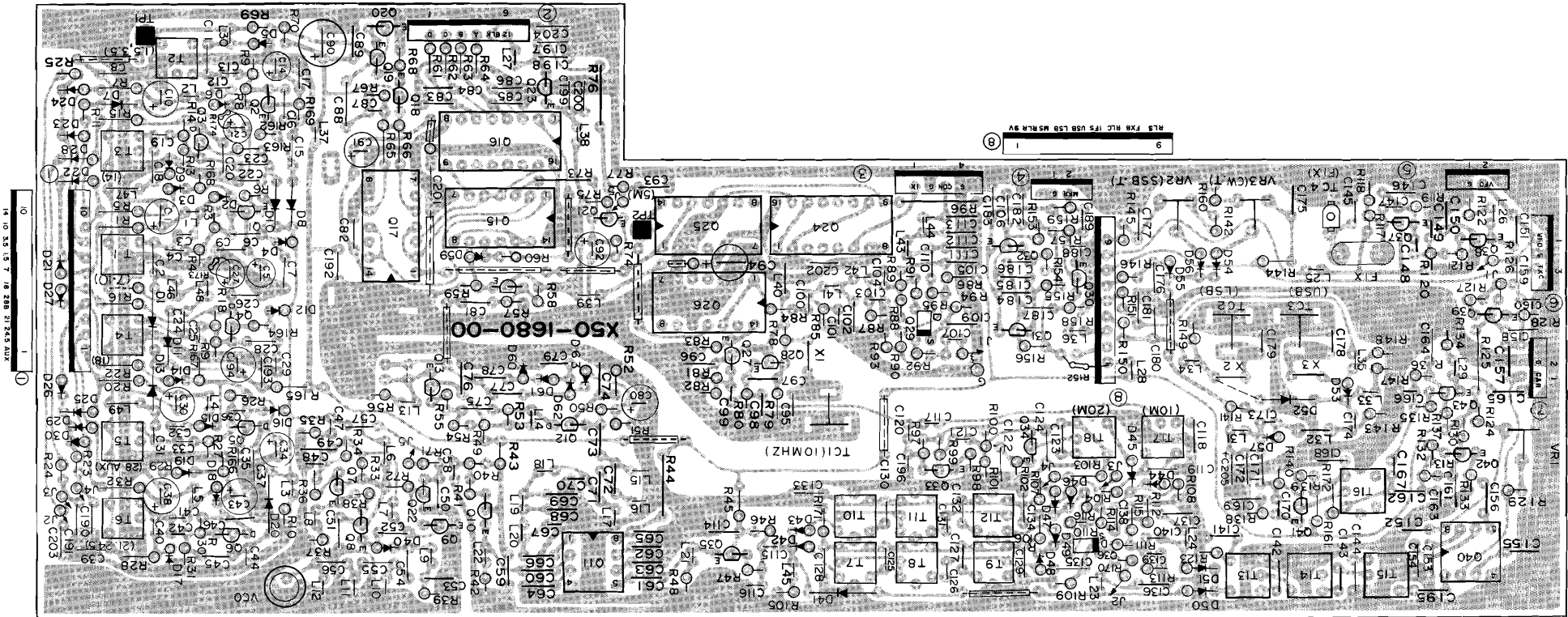
- Q1,2,7 2SC1815(Y)
- Q3: SN74LS00N
- Q4 TC4029BP  
or MC14510BCP
- Q5 TC5070P
- Q6 TC4518BP
- Q8,9 TC4081BP
- Q10 TC5066BP
- Q11 TC5064BP
- Q12,13 2SC1959(Y)
- Q14: TC4011BP

- D1: XZ-055
- D2~5,8~27,29~31,  
33~62. 1S1555
- D6: WZ-110
- D7: XZ-060
- D28: 1N60



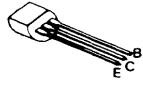
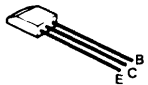
RB1 ~ 4

- Q1,2,7 : 2SC1815(Y)
- Q3 : SN74LS00N
- Q4 : TC4029BP
- Q5 : TC5070P
- Q6 : TC4518BP
- Q8,9 : TC4081BP
- Q10 : TC5066BP
- Q11 : TC5064BP
- Q12,13 : 2SC1959(Y)
- Q14 : TC4011BP
- D1 : XZ-055
- D6 : WZ-110
- D7 : XZ-060
- D28 : 1N60
- D2~5,8~27,29~31,  
33~62,101~110 : 1S1555



2SC1815 (BL), (Y)  
 2SC1923 (O)  
 2SC1959 (Y)

2SC460 (B)



2SK19 (BL), (GR)

3SK73 (GR)

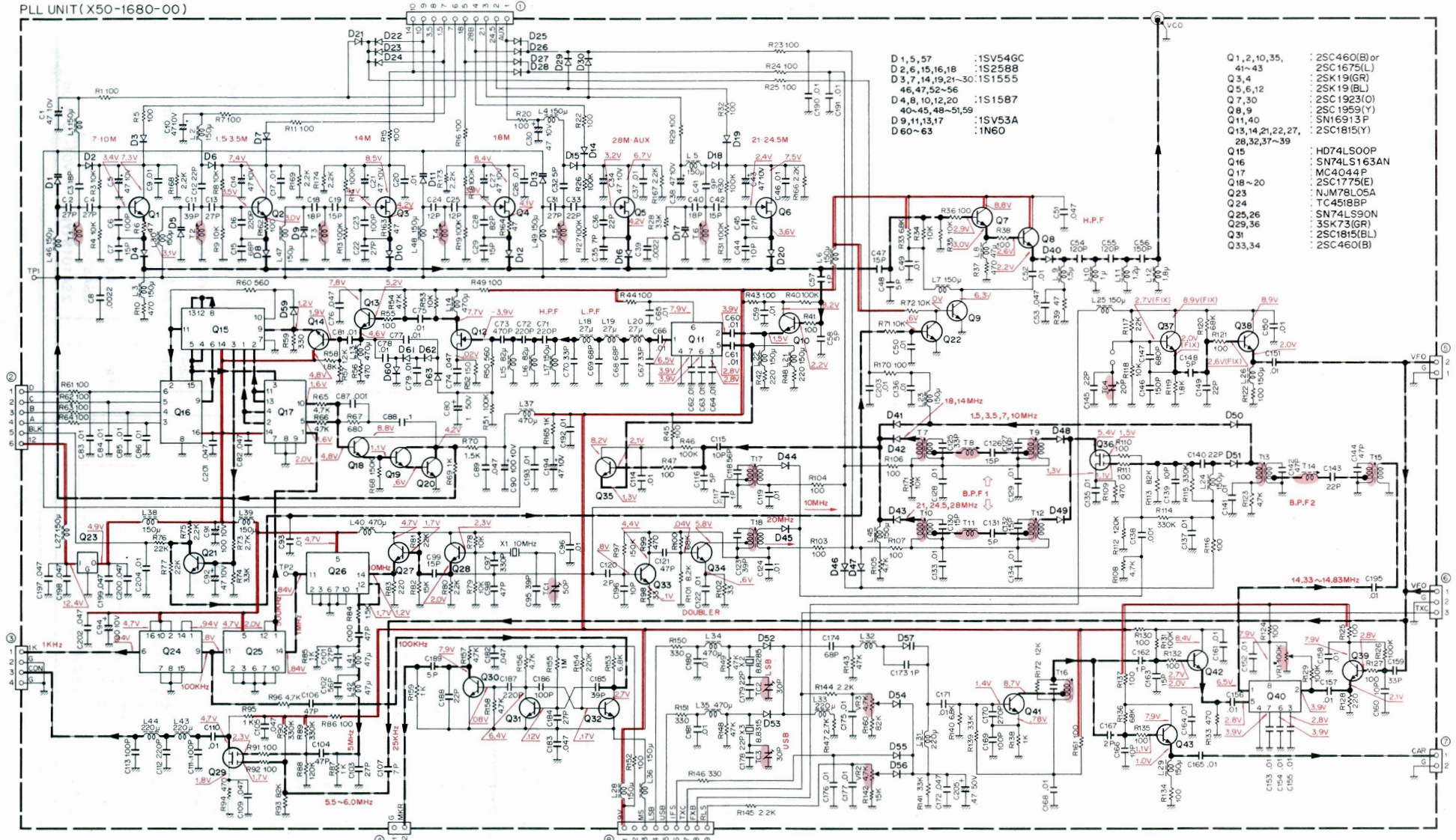


Q1.2 10.35.41~43 2SC460(B) or 2SC1675(L) Q3.4 2SK19(GR) Q5.6 12 2SK19(BL) Q7.30 2SC1923(O) Q8.9 2SC1959(Y)  
 Q11 40 SN16913P  
 Q13 14.21.22.27.28.32.37~39 2SC1815(Y) Q15 HD74LS00P or SN74LS00N Q16 74LS163N or SN74LS163AN or HD74LS163P  
 Q17 MC4044P Q18~20 2SC1775  
 Q23 NJM78L05A Q24 TC4518BP Q29.36 3SK73(GR) Q25.26 SN74LS90N or HD74LS90P Q31 2SC1815(BL) Q33.34 2SC460(B)  
 D1.5.57 1S1555 D2.6.15.18.16 1S2588 D3.7 14 19.21~30.46.47.52~56 1S1555 D4.8.10.12 20.40~45 48~51.59 1S1587  
 D9.11 13.17 1S1553A D60~63 1N60



▼ PLL UNIT (X50-1680-00)

PLL UNIT(X50-1680-00)



- D 1, 5, 57 :1SV54GC
- D 2, 6, 15, 16, 18 :1S2588
- D 3, 7, 14, 19, 21-30 :1S1555
- D 4, 6, 47, 52, 56
- D 4, 8, 10, 12, 20 :1S1587
- 40-45, 48-51, 59
- D 9, 11, 13, 17 :1SV53A
- D 60-63 :1N60

- Q 1, 2, 10, 35, :25C460(B) or
- 41-43 :25C1675(L)
- Q 3, 4 :25K19(GR)
- Q 5, 6, 12 :25K19(BL)
- Q 7, 30 :25C1923(O)
- Q 8, 9 :25C1959(Y)
- Q 11, 40 :SN16913 P
- Q 13, 14, 21, 22, 27, :25C1815(Y)
- 28, 32, 37-39
- Q 15 :HD74LS00P
- Q 16 :SN74LS163AN
- Q 17 :MC4044P
- Q 18-20 :25C1775(E)
- Q 23 :NJM78L05A
- Q 24 :TC4518BP
- Q 25, 26 :SN74LS90N
- Q 29, 36 :35K73(GR)
- Q 31 :25C1815(BL)
- Q 33, 34 :25C460(B)

SCHEMATIC TS-830S, M

# PARTS LIST

**Note 1**

K U.S.A. T Britain W Europe X Australia

**Note 2:**

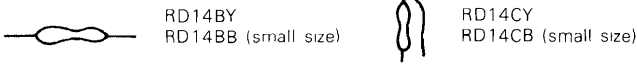
Only special type of resistors (example cement, metal film, etc.) and capacitors (example, electrolytic, tantalum, mylar, temp. coeff. capacitors) are detailed in the PARTS LIST. For the value of all common type components, refer to the schematic diagram of the P.C. board illustration. Resistors not otherwise detailed are carbon type (1/4W or 1/8W). Order carbon resistors and capacitors according to the following example:

A carbon resistor's part number is RD14BY 2E222J

A ceramic capacitor's number is CK45F1H103Z. CC45TH1H220J

**RESISTOR**

**1 Type of the carbon resistor**



**2. Wattage**

1W → 3A    3W → 3F    5W → 3H  
2W → 3D    4W → 3G

**3' = CC45** ○ ○ ...

Ceramic capacitor (type I) temperature coeff. capacitor 1' 3'

1st word (Color)	C (Black)	L (Red)	P (Orange)	R (Yellow)	S (Green)	T (Blue)	U (Violet)
ppm/°C	0	-80	-150	-220	-330	-470	-750

**3 = CK45** ○

Ceramic capacitor (type II) 3

Cord	B	D	E	F
Operating temperature °C	-30 +85	-30 +85	-30 +85	-10 +70

**6 = Tolerance**

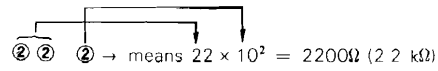
Cord	C	D	G	J	K	M	X	Z	P	No cord
(%)	±0.25	±0.5	±2	±5	±10	±20	+40 -20	+80 -20	+100 -0	More than 10 μF -10 ~ +50 Less than 4.7 μF -10 ~ +75

**Less than 10 pF**

Cord	B	C	D	F	G
(pF)	±0.1	±0.25	±0.5	±1	±2

Abbreviation		Abbreviation	
Cap.	Capacitor	ML	Mylar
C	Ceramic	S	Styren
E	Electrolytic	T	Tantalum
MC	Mica		

**3. Resistance value**



Example 221 → 220Ω    223 → 22 kΩ    225 → 2.2 MΩ  
222 → 2.2 kΩ    224 → 220 kΩ

**4. Tolerance**

J = ±5% (Gold)    K = ±10% (Silver)

**CAPACITORS**

**Type I**

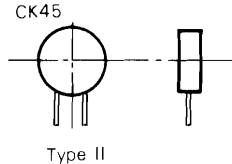
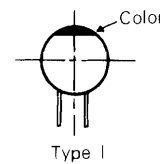
**Type II**

CC 45 TH 1H 220 J    CK 45 F 1H 103 Z  
1' 2 3' 4 5 6    1 2 3 4 5 6  
1 = Type    ceramic, electrolytic, etc    4 = Voltage rating  
2 = Shape    round, square, etc    5 = Value  
3 = Temp range    6 = Tolerance  
3' = Temp coefficient

Ex CC45TH = -470 ±60 ppm/°C

2nd Word	G	H	J	K	L
ppm/°C	±30	±60	±120	±250	±500

**CC45**



Type I

Type II

**5 = Capacitor value**

Example 010 → 1 pF  
100 → 10 pF  
101 → 100 pF  
102 → 1000 pF = 0.001 μF  
103 → 0.01 μF

**TS-830 Semiconductor, Tube**

☆ New Parts

Item	Name	Parts No.	Re- marks
Diode	1N60	V11-0051-05	
	1S1007	V11-4160-66	
	1S1555	V11-0076-05	
	1S1587	V11-0370-05	
	1S2588	V11-0414-05	
	V03C	V11-0290-05	200V 1.3A
	V06B	V11-0219-05	100V 1 1A
Varistor	V06E	V11-0285-05	400V 1 1A
	V08J	V11-0282-05	800V 1 1A
	MV-13	V21-0004-05	
Vari-cap diode	1SV53A	V11-4161-36	
	1SV54GC	V11-4173-46	

Item	Name	Parts No.	Re- marks
Zener diode	WZ-061	V11-0243-05	
	WZ-071	V11-4160-86	
	WZ-090	V11-0240-05	
	XZ-055	V11-4105-50	
	XZ-060	V11-4101-20	
	XZ-090	V11-4167-06	
LED	SLP-144	V11-6172-76	
	TLR-205	V11-3162-96	
Display Tube	9-BT-12	V40-7760-86	
	6146B	V40-0138-00	☆
Tube	12BY7A	V40-0114-00	
	TR	2SA473 (Y)	V01-0473-06
2SA562 (Y)		V01-0032-05	
2SA1015 (Y)		V01-1015-06	

# PARTS LIST

TS-830S, M

Item	Name	Parts No.	Re- marks
	2SC460 (B)	V03-0079-05	
	2SC945 (Q)	V03-0293-05	
	2SC1515 (K)	V03-0450-05	
	2SC1675 (L)	V03-1675 10	
	2SC1775 (E)	V03-1775-06	
	2SC1815 (BL)	V03-1815-26	
	2SC1815 (GR)	V03-1815-16	
	2SC1815 (Y)	V03-1815-06	
	2SC1923 (O)	V03-1923-06	
	2SC1959 (Y)	V03-1959-06	
	2SC2240 (GR)	V03-2240-06	
FET	2SK19 (BL)	V09-0013-05	
	2SK19 (GR)	V09-0012-05	
	2SK19 (Y)	V09-0011-05	
	2SK30A (GR)	V09-0060-05	
	2SK30A (O)	V09-0056-05	
	2SK125	V09-0136-10	
	3SK73 (GR)	V09-1002-46	
IC	74LS163N	V30-1037-06	
	HA1368R	V30-1129-06	
	HD74LS00P	V30-0192-16	
	HD74LS163P	V30-1047-06	
	HD74LS90P	V30-1083-06	
	MC14510BCP	V30-1227-16	
	MC4044P	V30-0173-05	
	NJM78L05A	V30-1020-16	
	SN16913P	V30-1048-06	
	SN74LS00N	V30-0301-30	
	SN74LS163AN	V30-1154-06	
	SN74LS90N	V30-1005-26	
	TA7302P	V30-1134-06	
	TC4011BP	V30-0301-70	
	TC4029BP	V30-1051-06	
	TC4081BP	V30-0299-10	
	TC4518BP	V30-1039-06	
	TC5064BP	V30-1056-06	
	TC5066BP	V30-1057-06	
	TC5070P	V30-1172-06	

Ref No.	Parts No.	Description	Re- marks
	B43-0649-04	Name plate M (W)	☆
	B43-0654-04	Name plate (T)	☆
	B43-0656-04	Name plate (K)(W)(X)	☆
	B46-0058-10	Warranty card (K)	
	B50-2738-00	Operating manual (K)	☆
	B50-2739-00	Operating manual (T)	☆
	B50-2740-00	Operating manual (W)(X)	☆
	B58-0625-00	Transmit warning paper	☆
	C01-0084-05	Variable cap. VC2 Load	
	C03-0002-05	Trimmer TC1	
	C03-0060-05	Variable cap. VC1 Final	
C1	CQ92M1H104K	ML 0.1μF 50V	
C6	C91-0016-05	C 3pF 3kV	
C7	C90-0186-05	C 0.001μF 3kV	
C8	C91-0079-05	C 0.01μF 2kV	
C9	C91-0401-05	C 100pF 3kV	
C10	C91-0017-05	C 390pF 3kV	
C12	CC45SL2H101J	C 100pF 500V	
C13	CC45SL2H271J	C 270pF 500V	
C14	CC45SL2H681J	C 680pF 500V	
C15	CC45SL2H121J	C 120pF 500V	
C16	CC45SL2H821J	C 820pF 500V	
C17	CC45SL2H102J	C 1000pF 500V	
C18.19	C90-0300-05	C 470pF AC150V	
C20	C91-0079-05	C 0.01μF 2kV	
C22. 24	C90-0327-05	E 100μF 500V	
C26	C91-0467-05	C 22pF 3kV	☆
C30	CC45SL1H030C	C 3pF ±0.25pF	
C31	CC45SL2H101J	C 100PF 500V	
	D22-0402-05	Universal coupling, Band Load	
	D22-0405-04	Coupling, PLATE	
	D22-0407-04	Shaft coupling, φ6	☆
	D32-0051-04	Shaft stopper, M3 × 10	
	D40-0206-05	Fan ass'y	
	D40-0613-05	Vernier mechanism	☆
	E04-0152-05	UHF type receptacle, ANT	
	E06-0451-15	4P male socket, MIC	
	E06-0751-05	7P DIN socket, REMOTE	
	E06-0851-05	8P DIN socket, EXT VFO, XVTR	
	E07-0751-05	7P DIN plug	
	E08-0204-05	2P connector	
	E08-1202-05	12P connector	
	E08-1207-05	12P plug	
	E09-0204-05	2P plug	
	E11-0404-05	3P Phone jack, Key, Phone	
	E11-0410-05	Phone jack, Ext SP	
	E12-0001-05	Phone plug, Ext. SP	
	E13-0205-05	2P Pin jack, IF OUT 1, 2	
	E20-0512-05	5P terminal	
	E22-0207-05	Lug plate	
	E22-0215-05	Lug plate	
	E23-0046-04	Square terminal	
	E29-0417-04	Gnd plate	
	E30-0181-05	AC cord (K)	
	E30-0185-05	AC cord (X)	
	E30-0585-05	AC cord (W)	
	E30-0602-05	AC cord (T)	
	E90-0004-15	Plate cap	
	E31-2086-05	Coax cable with plug	☆

## TS-830 GENERAL

M(W): TS-830M (W) type

Ref. No.	Parts No.	Description	Re- marks
	A01-0778-11	Case (Upper)	☆
	A01-0779-01	Case (Lower)	☆
	A20-2388-13	Panel	☆
	B03-0519-04	Switch mask (A)	☆
	B03-0520-04	Switch mask (B)	☆
	B05-0708-04	Speaker grill cloth	
	B09-0003-05	Coupling	
	B10-0630-04	Front glass (large)	☆
	B10-0631-04	Front glass (small)	☆
	B21-0501-04	Pointer Plate	☆
	B30-0817-15	Pilot lamp Meter 14V, 80mA	☆
	B31-0627-05	Meter	☆
	B42-1691-04	Adj. seal	☆

**PARTS LIST**

Ref. No.	Parts No.	Description	Re- marks
	F05-4022-05	Fuse, 4A (W)(T)(X)	
	F05-6021-05	Fuse, 6A (K)	
	G01-0801-04	GND spring	
	G09-0405-05	D spring, Mode	
	G09-0410-05	D spring, RIT, Plate	
	H01-2692-14	Carton case (inside)(K)(W)(X)	☆
	H01-2695-14	Carton case (inside)(T)	☆
	H03-1763-14	Carton case (outside)	☆
	H10-1276-04	Accessory box	
	H10-2539-02	Packing fixture (F)	☆
	H10-2540-02	Packing fixture (R)	☆
	H20-0439-03	Protective cover	
	H25-0120-04	Protective bag	
	J02-0022-05	Foot (small)	
	J02-0049-14	Foot (large)	
	J13-0407-15	Fuse holder	☆
	J32-0159-04	Hex. boss	
	J32-1030-14	Round boss	
	J41-0006-05	Cord bush (K)	
	J41-0024-15	Cord bush (W)(T)(X)	
	J42-0409-04	Knob bush, +0.5 Shift	
	K01-0402-25	Handle	
	K21-0723-04	Knob, Band	
	K23-0738-04	Knob 1, Meter, AGC	☆
	K23-0739-04	Knob 2, COMP.GAIN.NB.DELAY	☆
	K23-0740-04	Knob 3, MIC.VBT.IF Shift, AF	☆
	K27-0406-04	Push knob, DH	
	K27-0421-04	Push knob	☆
	K29-0713-04	Push knob, 0.5 Shift	
	K29-0715-04	Knob, Mode	
	K29-0736-14	Knob 4, Notch,CAR,RF,Tone	☆
	K29-0737-04	Knob 5, Plate	☆
	K29-0738-04	Knob 6, RIT,Drive,Load	☆
	L01-8106-15	Power Trans (K)	☆
	L01-8116-15	Power trans (W)(T)(X)	☆
	L33-0259-05	Choke coil, 470μH, L5	
	L33-0635-05	Final choke, L2	☆
	L34-0560-25	Final coil A	
	L34-1004-05	Final coil B, 28MHz	
	L39-0046-05	PS coil, Plate	
	L40-1511-03	Ferri-inductor, 150μH	
	L40-6891-13	Choke coil, 6.8μH, L1	
	N08-0505-04	Ornamental screw, DH	☆
	N14-0517-05	Protective nut, BIAS	☆
	N99-0306-04	Hex. head screw, VFO	
VR1	R24-3402-05	Pot, VBT-Tone	☆
VR2	R24-9401-05	Pot, IF Shift-Notch	☆
VR3	R19-3407-05	Pot, AF-RF	☆
VR4	R01-2405-05	Pot, RIT/XIT, 5K (B)	☆
VR5	R01-6401-05	Pot, Delay, 250K (B)	☆
VR6	R01-3412-05	Pot, Vox Gain, 10K (C) S	☆
VR7	R01-3410-05	Pot, Processor, 10K (A)	☆
VR8	R01-0404-05	Pot, NB, 300Ω (B)	☆
VR9	R24-3401-05	Pot, MIC-CAR	☆
VR10~12	R01-3411-05	Pot, Bias, RFOUT, 10K (B)	☆
R22	RC05GF2H221J	Solid 220Ω 1/2W	

Ref. No.	Parts No.	Description	Re- marks
R24	RC05GF3A103K	Solid 10kΩ 1W	
R25,26	RC05GF2H474J	Solid 470kΩ 1/2W	
R28	RC05GF2H150J	Solid 15Ω 1/2W	
S1~6	S40-2419-05	Push switch PC board type	☆
S7	S40-2403-05	Push switch +0.5 SHIFT	
S8,9	S59-2020-05	Seesaw switch Power, Heater	
S11	S01-1423-05	Rotary switch AGC	
S12	S40-2403-05	Push switch DH	
S13	S01-1424-05	Rotary switch Meter	☆
S15,16	S40-2415-05	Push switch Lead type	
S17	S44-1407-05	Paddle switch STBY	☆
S18	S01-3405-15	Rotary switch Mode	☆
S20	S31-2007-05	Slide switch SG SW	
S22	S01-3406-05	Rotary switch FINAL	☆
S23	S31-2027-05	Slide switch AC Volt (W)(T)(X)	
RL1	S51-2409-05	Relay MX-2P	☆
	T03-0027-15	Speaker	
	X40-1170-00	VFO unit	☆
	X43-1370-00	Rectifier unit	☆
	X44-1360-00	RF unit	☆
	X48-1290-00	IF unit	☆
	X48-1290-61	IF unit M (W)	☆
	X49-1140-00	AF-AVR unit	☆
	X50-1680-00	PLL unit	☆
	X54-1540-00	Counter unit	☆
	X54-1610-60	AM unit M (W)	☆
	X56-1380-00	Final unit (S)	☆

**Rectifier unit (X43-1370-00)**

Ref. No.	Parts No.	Description	Re- marks
C5,6	CE02W2C330	E 33μF 160V	
	E23-0047-04	Square terminal	
	J31-0502-04	PC board collar	
	J42-0404-05	PC board bush	
L1	L40-1511-03	Ferri-inductor 150μH	
R1~4	RC05GF2H474J	Solid 470kΩ 1/2W	
R9	RC05GF2H334J	Solid 330kΩ 1/2W	
R10	RC05GF2H153J	Solid 15kΩ 1/2W	
R11	RS14AB3A471J	Metal film 470Ω 1W	
R13	RC05GF2H104J	Solid 100kΩ 1/2W	
R14	RC05GF2H102J	Solid 1kΩ 1/2W	
R15,16	RC05GF2H563J	Solid 56kΩ 1/2W	
RL1	S51-1404-05	Relay G2E	

**RF unit (X44-1360-00)**

Ref. No.	Parts No.	Description	Re- marks
C1	CQ92M1H182K	ML 0.0018μF 50V	
C4	CQ92M1H152K	ML 0.0015μF 50V	
C6	CC45R1H101J	C 100pF	
C7	CQ09S1H122J	S 0.0012μF 50V	



# PARTS LIST

TS-830S, M

Ref. No.	Parts No.	Description	Re- marks
C8	CC45RH1H221J	C 220pF	
C9	CC45RH1H330J	C 33pF	
C10	CC45RH1H121J	C 120pF	
C11	CC45RH1H560J	C 56pF	
C12	CC45RH1H330J	C 33pF	
C13	CC45RH1H101J	C 100pF	
C14, 15	CC45RH1H330J	C 33pF	
C16	CC45SL1H561J	C 560pF	
C17	CC45RH1H221J	C 220pF	
C19	CC45RH1H100D	C 10pF ±0.5pF	
C20	CC45RH1H330J	C 33pF	
C21	CC45RH1H121J	C 120pF	
C22	CC45RH1H560J	C 56pF	
C23	CC45RH1H330J	C 33pF	
C24	CC45RH1H101J	C 100pF	
C25	CC45RH1H330J	C 33pF	
C26	C91-0456-05	C 0.047μF	
C28	CC45SL1H561J	C 560pF	
C29	CK45E2H103P	C 0.01μF 500V	
C30	CC45RH2H330J	C 33pF 500V	
C31	CC45RH2H121J	C 120pF 500V	
C32	CC45RH2H181J	C 180pF 500V	
C33	CC45RH2H470J	C 47pF 500V	
C34	CC45RH2H270J	C 27pF 500V	
C35	CC45RH2H101J	C 100pF 500V	
C36	CC45RH2H390J	C 39pF 500V	
C37	CC45RH2H180J	C 18pF 500V	
C38	CC45SL2H100D	C 10pF ±0.5pF 500V	
C39	CK45E2H103P	C 0.01μF 500V	
C40	CC45SL2H561J	C 560pF 500V	
C41	CC45RH1H150J	C 15pF	
C42	CC45SL1H101J	C 100pF	
C45, 46	C91-0456-05	C 0.047μF	
C49	CC45SL1H100D	C 10P ±0.5pF	
C50	CC45SL1H470J	C 47pF	
C55	C91-0456-05	C 0.047μF	
C56	CC45RH1H101J	C 100pF	
C57	C91-0456-05	C 0.047μF	
C58	C91-0456-05	C 0.047μF	
C61	CC45SL1H470J	C 47pF	
C62	CC45RH1H150J	C 15pF	
C63	CC45SL1H151J	C 150pF	
C66	C91-0456-05	C 0.047μF	
C67	C91-0456-05	C 0.047μF	
C68	CK45E2H222P	C 0.0022μF 500V	
C69	CC45SL2H151J	C 150pF 500V	
C70	CK45B2H102K	C 0.001μF 500V	
C72~74	CK45E2H103P	C 0.01μF 500V	
C75	CC45CH2H680J	C 68pF 500V	
C77	CC45CH2H010C	C 1pF ±0.25pF 500V	
C78	C91-0456-05	C 0.047μF	
C81	CC45SL1H100D	C 10pF ±0.5pF	
VC1~3	C01-0127-15	Variable capacitor	
	D13-0404-04	Sprocket, large	☆
	D13-0405-04	Sprocket, small	☆
	D16-0403-04	Chain ass'y	☆
	E04-0154-05	Coax connector	
	E10-1902-05	9P tube socket	
	F11-0249-05	Tube shield	

Ref. No.	Parts No.	Description	Re- marks
	J31-0502-04	PC board collar	
	J42-0404-05	PC board bush	
T1	L19-0303-05	Wide band trans	
T2	L30-0509-05	IFT	
T3	L19-0303-05	Wide band trans	
T4	L30-0509-05	IFT	☆
L1	L40-2792-02	Ferri-inductor 2.7μH	
L2	L40-4791-02	Ferri-inductor 4.7μH	
L3	L34-0559-05	Trap coil	
L4	L34-0558-05	Trap coil	
L5	L34-0930-05	Tuning coil 3.5MHz	☆
L6	L34-0931-05	Tuning coil 7MHz	☆
L7	L34-0932-05	Tuning coil 10MHz	☆
L8	L34-0933-05	Tuning coil 14MHz	☆
L9	L34-0934-05	Tuning coil 18MHz	☆
L10	L34-0990-05	Tuning coil 21MHz	☆
L11	L34-0935-05	Tuning coil 24.5 MHz	☆
L12	L34-0995-05	Tuning coil 28MHz	☆
L13	L34-0936-05	Tuning coil MIX 1.5 MHz	☆
L14	L34-0930-05	Tuning coil 3.5MHz	☆
L15	L34-0931-05	Tuning coil 7MHz	☆
L16	L34-0932-05	Tuning coil 10MHz	☆
L17	L34-0933-05	Tuning coil 14MHz	☆
L18	L34-0934-05	Tuning coil 18MHz	☆
L19	L34-0990-05	Tuning coil 21MHz	☆
L20	L34-0935-05	Tuning coil 24.5MHz	☆
L21	L34-0995-05	Tuning coil 28MHz	☆
L22	L34-0559-05	Trap coil	
L23	L34-0552-15	Tuning coil 1.5MHz	
L24	L34-0553-15	Tuning coil 3.5MHz	
L25	L34-0554-05	Tuning coil 7MHz	
L26	L34-0937-05	Tuning coil 10MHz	☆
L27	L34-0555-05	Tuning coil 14MHz	
L28	L34-0938-05	Tuning coil 18MHz	☆
L29	L34-0556-05	Tuning coil 21MHz	
L30	L34-0939-05	Tuning coil 24.5MHz	☆
L31	L34-0557-05	Tuning coil 28MHz	
L32~34	L40-4711-03	Ferri-inductor 470μH	
L35	L40-1511-03	Ferri-inductor 150μH	
L36	L40-4711-03	Ferri-inductor 470μH	
L37, 38	L40-1511-03	Ferri-inductor 150μH	
L39	L33-0074-05	Heater choke 0.3μH	
L40	L40-2282-01	Ferri-inductor 0.22μH	
L41	L34-2004-05	Tuning coil ANT 1.5MHz	☆
L42	L40-4711-03	Ferri-inductor 470μH	
L43	L40-1511-03	Ferri-inductor 150μH	
L44	L40-2282-01	Ferri-inductor 0.22μH	
L45, 46	L40-1511-03	Ferri-inductor 150μH	
VR1	R12-0416-05	Trim. pot 470Ω	☆
VR2	R12-6404-05	Trim. pot 470kΩ	☆
R34	RC05GF2H104J	Solid 100kΩ 1/2W	
R35	RC05GF2H101J	Solid 100Ω 1/2W	
R36	RC05GF2H104J	Solid 100kΩ 1/2W	
R37	RS14AB3A332J	Metal film 3.3kΩ 1/2W	
R38	RC05GF2H474J	Solid 470kΩ 1/2W	
R41	RC05GF2H680J	Solid 68Ω 1/2W	
	R92-0150-05	Short jumper	
	S29-7401-05	Rotary wafer ass'y	☆

**PARTS LIST**

IF unit (X48-1290-00, 61) 00 : 830S (K)(W)(T)(X)  
61 : 830 M (W)

Ref No	Parts No.	Description	Re- marks
C2	C91-0457-05	C 0.022μF	
C4	CC45SL1H470J	C 47pF	
C5	CC45SL1H030C	C 3pF ±0.25pF	
C7, 8	CC45SL1H470J	C 47pF	
C10	CE04W1E100M	E 10μF 25V	
C11~15	C91-0457-05	C 0.022μF	
C16	C91-0456-05	C 0.047μF	
C18, 19	C91-0456-05	C 0.047μF	
C21, 22	C91-0456-05	C 0.047μF	
C24~26	CE04W1H010M	E 1μF 50V	
C28, 29	CE04W1H010M	E 1μF 50V	
C33	C91-0456-05	C 0.047μF	
C35	C91-0457-05	C 0.022μF	
C37	CE04W1E100M	E 10μF 25V	
C38	CC45SL1H101J	C 100pF	
C39	C91-0456-05	C 0.047μF	
C41, 42	CQ09FS1H102J	S 0.001μF 50V	
C47	CE04W1E100M	E 10μF 25V	
C48	C91-0456-05	C 0.047μF	
C50, 51	C91-0456-05	C 0.047μF	
C52	C91-0456-05	C 0.047μF	
C54	CE04W1E100M	E 10μF 25V	
C55	C91-0456-05	C 0.047μF	
C56	CC45SL1H101J	C 100pF	
C57	C91-0456-05	C 0.047μF	
C58	CC45SL1H470J	C 47pF	
C60	CE04W1E100M	E 10μF 25V	
C61	CC45UJ1H680J	C 68pF	
C62, 63	C91-0457-05	C 0.022μF	
C66	CS15E1VR22M	T 0.22μF 35V	
C67	CC45UJ1H100D	C 10pF ±0.5pF	
C68	CC45UJ1H030C	C 3pF ±0.25pF	
C71	CC45SL1H470J	C 47pF	
C72	C91-0457-05	C 0.022μF	
C73	CC45SL1H150J	C 15pF	
C74	CC45SL1H030C	C 3pF ±0.25pF	
C75	C91-0457-05	C 0.022μF	
C76, 77	CC45SL1H101J	C 100pF	
C78	CC45SL1H100D	C 10pF ±0.5pF	
C79	C91-0457-05	C 0.022μF	
C82	CC45SL1H020C	C 2pF ±0.25pF	
C83	CE04AW1HR22M	E 0.22μF 50V	
C84	C91-0456-05	C 0.047μF	
C86	C91-0456-05	C 0.047μF	
C87	CC45SL1H050C	C 5pF ±0.25pF	
C88	CC45SL1H101J	C 100pF	
C89	C91-0456-05	C 0.047μF	
C91	CE04W1E100M	E 10μF 25V	
C92, 93	C91-0456-05	C 0.047μF	
C95	CC45SL1H101J	C 100pF	
C96~98	C91-0456-05	C 0.047μF	
C99	CC45UJ1H151J	C 150pF	
C100	C91-0457-05	C 0.022μF	
C102, 103	CC45SL1H101J	C 100pF	
C104	CE04W1H010M	E 1μF 50V	
C105	CE04W1C100M	E 10μF 16V	
C106	CQ92M1H153M	ML 0.015μF	
C107	CE04W1H010M	E 1μF 50V	
C108	C91-0456-05	C 0.047μF	
C109	CE04W1A470M	E 47μF 10V	
C110	CE04W1C100M	E 10μF 16V	

Ref No.	Parts No.	Description	Re- marks
C111	CE04W1H010M	E 1μF 50V	
C112	CE04W1A221M	E 220μF 10V	
C113	CE04W1H3R3M	E 3.3μF 50V	
C114	CE04W1H010M	E 1μF 50V	
C115	CC45SL1H101J	C 100pF	
C116	CC45SL1H331J	C 330pF	
C117	C91-0456-05	C 0.047μF	
C119	CE04W1C220M	E 22μF 16V	
C121	CE04W1H010M	E 1μF 50V	
C123	C91-0456-05	C 0.047μF	
C127	CC45SL1H470J	C 47pF	
C129	CE04W1A470M	E 47μF 10V	
C130, 131	C91-0456-05	C 0.047μF	
C132	CC45SL1H100D	C 10pF ±0.5pF	
C134	CE04W1E100M	E 10μF 25V	
C135, 136	C91-0456-05	C 0.047μF	
C138	CE04W1E100M	E 10μF 25V	
C142	C91-0456-05	C 0.047μF	
C144	C91-0456-05	C 0.047μF	
C145	CE04W1E100M	E 10μF 25V	
C149	C91-0456-05	C 0.047μF	
C150	CC45SL1H330J	C 33pF	
C151	CC45SL1H100D	C 10pF ±0.5pF	
C152	C91-0456-05	C 0.047μF	
C153, 154	C91-0457-05	C 0.022μF	
C157	C91-0457-05	C 0.022μF	
C159	C91-0457-05	C 0.022μF	
C160	CC45SL1H020C	C 2pF ±0.25pF	
C161	Not used		
C162	C91-0457-05	C 0.022μF	
C163	CC45SL1H100D	C 10pF ±0.5pF	
C164	CC45SL1H330J	C 33pF	
C165	CC45SL1H050C	C 5pF ±0.25pF	
C166	CE04W1HR47M	E 0.47μF 50V	
C167	CC45SL1H101J	C 100pF	
C168	CQ92M1H822K	ML 0.0082μF 50V	
C169	CQ92M1H153K	ML 0.015μF 50V	
C170	CE04W1HR47M	E 0.047μF 50V	
C171	CE04W1H4R7M	E 4.7μF 50V	
C172	CQ92M1H273K	ML 0.027μF 50V	
C173	CE04W1A101M	E 100μF 10V	
C174, 175	CE04W1A470M	E 47μF 10V	
C177	CE04W1H010M	E 1μF 50V	
C178~181	CE04W2V220	E 22μF 350V	
TC1	C05-0314-05	Ceramic trimmer 100pF	☆
TC2	C05-0030-15	Ceramic trimmer 20pF	
TC3	C05-0314-05	Ceramic trimmer 100pF	☆
	E23-0401-05	Round terminal	
L1	L40-1511-03	Ferri-inductor 150μH	
L2	L34-0940-05	Tuning coil 8.83MHz	☆
L3	L34-0536-05	Tuning coil	
L4	L34-0941-05	Tuning coil 8.83MHz	☆
L5	L34-0997-05	Tuning coil 8.83MHz	☆
L6	L34-0943-05	Tuning Coil 8.83MHz	☆
L7	L34-0664-05	Tuning coil 455kHz	
L8	L40-1021-03	Ferri-inductor 1mH	
L9	L34-0540-05	Tuning coil 455kHz	
L10	L34-0944-05	Tuning coil Notch	☆
L11	L34-0540-05	Tuning coil 455kHz	
L12	L34-2017-05	Tuning coil 455kHz	☆

# PARTS LIST

TS-830S, M

Ref No.	Parts No.	Description	Re- marks
L13	Not Used		
L14	L33-0636-05	Choke coil	
L15	L40-2211-03	Ferri-inductor 220 $\mu$ H	
L16	L32-0201-05	Oscillating coil	
L17	L40-3391-03	Ferri-inductor 3.3 $\mu$ H	
L18	L40-1511-03	Ferri-inductor 150 $\mu$ H	
L19, 20	L34-0540-05	Tuning coil 455kHz	
L21, 22	L40-1021-03	Ferri-inductor 1mH	
L23	Not Used		
L24	L34-0539-15	Tuning coil 455kHz BM	
L25	L34-0664-05	Tuning coil 455kHz	
L26, 27	L34-0540-05	Tuning coil 455kHz	
L28	L34-0536-05	Tuning coil 8.83MHz	
L29	L34-0946-05	Tuning coil 8.83MHz	☆
L31	L40-1511-03	Ferri-inductor 150 $\mu$ H	
L32	L40-1021-03	Ferri-inductor 1mH	
CF1	L72-0310-05	Ceramic filter 8.83MHz NB	
CF2	L72-0314-15	Ceramic filter 455kHz SSB	
CF3	L72-0322-05	Ceramic filter 456.5 kHz AM M(W)	☆
XF1	L71-0222-05	MCF 8.83MHz SSB YK-88S1	☆
XF2	L71-0223-05	MCF 8.8315MHz AMYK-88AM(W)	☆
X1	L77-0801-05	Crystal 8.375MHz	
VR1 2	R12-3045-05	Trim. pot 10k $\Omega$	
VR3	R12-6401-05	Trim. pot 470k $\Omega$	
VR4	R12-0401-05	Trim. pot 100 $\Omega$	
VR5	R12-1039-05	Trim. pot 2.2k $\Omega$	
VR6	R12-3045-05	Trim pot 10k $\Omega$	
VR7	R12-6401-05	Trim. pot 470k $\Omega$	
VR8	R12-3046-05	Trim. pot 47k $\Omega$	
	R92-0150-05	Short jumper	
R203	RS14GB3D471J	Metal film 470 $\Omega$ 2W	

## AF unit (X49-1140-00)

Ref. No.	Parts No.	Description	Re- marks
C2 ~ 5	CQ92M1H123K	ML 0.012 $\mu$ F 50V	
C6	CE04W1E100Q	E 10 $\mu$ F 25V	
C8	CE04W1H010	E 1 $\mu$ F 50V	
C9	CE04W1A101Q	E 100 $\mu$ F 10V	
C10	CQ92M1H273K	ML 0.027 $\mu$ F 50V	
C11	CE04W1HR47	E 0.47 $\mu$ F 50V	
C13	CE04W1A470Q	E 47 $\mu$ F 10V	
C14, 15	CQ92M1H273K	ML 0.027 $\mu$ F 50V	
C16	CQ92M1H473K	ML 0.047 $\mu$ F 50V	
C17	CQ92M1H273K	ML 0.027 $\mu$ F 50V	
C18	CQ92M1H473K	ML 0.047 $\mu$ F 50V	
C19	CE04W1E100Q	E 10 $\mu$ F 25V	
C20	CE04W1HR47	E 0.47 $\mu$ F 50V	
C21, 22	CE04W1E100Q	E 10 $\mu$ F 25V	
C23	CE04AW1HR47	E 0.47 $\mu$ F 50V	
C24	CE04W1H010	E 1 $\mu$ F 50V	
C25	CQ92M1H472K	ML 0.0047 $\mu$ F 50V	
C27	CE04W1H4R7M	E 4.7 $\mu$ F 50V	
C28	CE04W1C471M	E 470 $\mu$ F 16V	
C29, 30	CC45SL1H120J	C 12pF	
C31, 32	CE04W1C470Q	E 47 $\mu$ F 16V	
C33	CQ92M1H104K	ML 0.1 $\mu$ F 50V	
C34	CE04W1C221Q	E 220 $\mu$ F 16V	
C35	CQ92M1H103K	ML 0.01 $\mu$ F 50V	
C36	CE04AW1H0R1M	E 0.1 $\mu$ F 50V	

Ref No.	Parts No.	Description	Re- marks
C37, 38	CE04W1A470Q	E 47 $\mu$ F 10V	
C39	CE04W1C470Q	E 47 $\mu$ F 16V	
C41	CE04W1H3R3	E 3.3 $\mu$ F 50V	
C42	CE04W1E100Q	E 100 $\mu$ F 25V	
C43	CE04W1H010	E 1 $\mu$ F 50V	
C44	CQ92M1H103K	ML 0.01 $\mu$ F	
C45	CE04W1E100Q	E 10 $\mu$ F 25V	
C46	CQ92M1H472K	ML 0.0047 $\mu$ F 50V	
C47	CQ92M1H473K	ML 0.047 $\mu$ F 50V	
C49	CE04W1H3R3	E 3.3 $\mu$ F 50V	
C51, 52	CK45E2H103P	C 0.01 $\mu$ F 500V	
C53, 54	CQ93M2A473K	ML 0.047 $\mu$ F 100V	
C58	CQ93M2A224M	ML 0.22 $\mu$ F 100V	
C60	CE04W1HR47	E 0.47 $\mu$ F 50V	
C67	CC45SL1H100D	C 10pF $\pm$ 0.5pF	
C70	CE04W1H010	E 1 $\mu$ F 50V	
C74	CE04W1H010	E 1 $\mu$ F 50V	
C78	CE04W1C470Q	E 47 $\mu$ F 16V	
C81	CE04W1C102M	E 1000 $\mu$ F 16V	
C82	CE04W1H3R3	E 3.3 $\mu$ F 50V	
C83	CE04AW1HR22M	E 0.22 $\mu$ F 50V	
C84	C90-0807-05	E 2200 $\mu$ F 25V	
C89	CE04W1A470Q	E 47 $\mu$ F 10V	
C90	C91-0456-05	C 0.047 $\mu$ F	
C91	CE04W1E100Q	E 10 $\mu$ F 25V	
C92	CE04W1A330M	E 33 $\mu$ F 10V	
C48, 80	Not Used		
	E23-0047-04	Square terminal	
	F20-0516-05	Insulating sheet	☆
	F29-0014-05	Shoulder washer	☆
	J31-0502-04	PC board collar	
	J42-0404-05	PC board bush	
T1	L34-0535-05	Tuning coil NB Red	
T2	L34-0536-05	Tuning coil NB Blue	
L1	L40-3392-02	Ferri-inductor 3.3 $\mu$ H	
L2 ~ 4	L40-1511-03	Ferri-inductor 150 $\mu$ H	
L5	L15-0016-05	Choke trans	
VR1	R12-3411-05	Trim. Pot 47k $\Omega$	
VR2	R12-3413-05	Trim. Pot 10k $\Omega$	☆
VR3	R12-3411-05	Trim. Pot 47k $\Omega$	
VR4	R12-0413-05	Trim. Pot 470 $\Omega$	
	R92-0150-05	Short jumper	
RL1	S51-4401-05	Relay DC12V	

## PLL unit (X50-1680-00)

Ref No.	Parts No.	Description	Re- marks
C1	CE04W1A470Q	E 47 $\mu$ F 10V	
C2	CC45TH1H270J	C 27pF	
C3	CC45TH1H180J	C 18pF	
C4	CC45TH1H270J	C 27pF	
C5	CE04W1A470Q	E 47 $\mu$ F 10V	
C6	CC45UJ1H101J	C 100pF	
C7	CC45UJ1H150J	C 15pF	
C10	CE04W1A470Q	E 47 $\mu$ F 10V	
C11	CC45TH1H330J	C 33pF	
C12	CC45TH1H220J	C 22pF	
C13	CC45TH1H270J	C 27pF	

## PARTS LIST

Ref. No.	Parts No.	Description	Re- marks
C14	CE04W1A470Q	E 47 $\mu$ F 10V	
C15	CC45SH1H680J	C 68pF	
C16	CC45RH1H221J	C 220pF	
C18	CC45TH1H180J	C 18pF	
C19	CC45TH1H150J	C 15pF	
C21	CE04W1A470Q	E 47 $\mu$ F 10V	
C22	CC45UJ1H270J	C 27pF	
C23	CC45TH1H101J	C 100pF	
C24.25	CC45UJ1H120J	C 12pF	
C27	CE04W1A470Q	E 47 $\mu$ F 10V	
C28	CC45UJ1H820J	C 82pF	
C29	CC45UJ1H150J	C 15pF	
C30	CE04W1A470Q	E 47 $\mu$ F 10V	
C31	CC45TH1H270J	C 27pF	
C32	CC45UJ1H050C	C 5pF $\pm 0.25$ pF	
C33	CC45UJ1H220J	C 22pF	
C34	CE04W1A470Q	E 47 $\mu$ F 10V	
C35	CC45UJ1H070D	C 7pF $\pm 0.5$ pF	
C36	CC45UJ1H220J	C 22pF	
C38	CE04W1A470Q	E 47 $\mu$ F 10V	
C40	CC45UJ1H180J	C 18pF	
C41	CC45UJ1H090D	C 9pF $\pm 0.5$ pF	
C42	CC45TH1H150J	C 15pF	
C43	CE04W1A470Q	E 47 $\mu$ F 10V	
C44	CC45UJ1H100D	C 10pF $\pm 0.5$ pF	
C45	CC45UJ1H270J	C 27pF	
C47	CC45TH1H150J	C 15pF	
C48	CC45TH1H050C	C 5pF $\pm 0.25$ pF	
C51	C91-0456-05	C 0.047 $\mu$ F	
C53	C91-0456-05	C 0.047 $\mu$ F	
C54.55	CC45SL1H121J	C 120pF	
C56	CC45SL1H151J	C 150pF	
C57	CC45CH1H010C	C 1pF $\pm 0.25$ pF	
C58	CC45SL1H050C	C 5pF $\pm 0.25$ pF	
C67	CC45SL1H330J	C 33pF	
C68.69	CC45SL1H680J	C 68pF	
C70	CC45SL1H330J	C 33pF	
C71.72	CC45SL1H221J	C 220pF	
C74	C91-0456-05	C 0.047 $\mu$ F	
C76	C91-0456-05	C 0.047 $\mu$ F	
C80	CE04W1H010Q	E 1 $\mu$ F 50V	
C82	C91-0456-05	C 0.047 $\mu$ F	
C87	CQ92M1H102K	ML 0.001 $\mu$ F 50V	
C88	CQ92M1H104K	ML 0.1 $\mu$ F 50V	
C89	C91-0456-05	C 0.047 $\mu$ F	
C90.91	CE04W1A101Q	E 100 $\mu$ F 10V	
C92	CE04W1A470Q	E 47 $\mu$ F 10V	
C94	CE04W1A101M	E 100 $\mu$ F 10V	
C95	CC45SL1H390J	C 39pF	
C97	CC45SL1H331J	C 330pF	
C98	CC45SL1H470J	C 47pF	
C99	CC45SL1H150J	C 15pF	
C100	CC45SL1H470J	C 47pF	
C101	CC45SL1H270J	C 27pF	
C102	CC45SL1H560J	C 56pF	
C103	CC45SL1H270J	C 27pF	
C104	CC45SL1H470J	C 47pF	
C105	C91-0456-05	C 0.047 $\mu$ F	
C106	CC45SL1H470J	C 47pF	
C107	CC45SL1H070D	C 7pF $\pm 0.5$ pF	
C109	C91-0456-05	C 0.047 $\mu$ F	
C111	CC45SL1H101J	C 100pF	

Ref. No.	Parts No.	Description	Re- marks
C112	CC45SL1H221J	C 220pF	
C113	CC45SL1H101J	C 100pF	
C115	CC45RH1H100D	C 10pF $\pm 0.5$ pF	
C116	CC45TH1H050C	C 5pF $\pm 0.25$ pF	
C117	CC45CH1H010C	C 1pF $\pm 0.25$ pF	
C118	CC45RH1H560J	C 56pF	
C120	CC45CH1H020C	C 2pF $\pm 0.25$ pF	
C121	CC45SL1H470J	C 47pF	
C123	CC45RH1H390J	C 39pF	
C125	CC45TH1H330J	C 33pF	
C126	CC45TH1H150J	C 15pF	
C127	CC45TH1H330J	C 33pF	
C130	CC45UJ1H150J	C 15pF	
C131	CC45UJ1H050C	C 5pF $\pm 0.25$ pF	
C132	CC45UJ1H150J	C 15pF	
C139	CC45SL1H100D	C 10pF $\pm 0.5$ pF	
C140	CC45RH1H220J	C 22pF	
C142	CC45RH1H470J	C 47pF	
C143	CC45RH1H220J	C 22pF	
C144	CC45RH1H470J	C 47pF	
C145	CC45SL1H220J	C 22pF	
C146	CC45SL1H151J	C 150pF	
C148	CC45SL1H050C	C 5pF $\pm 0.25$ pF	
C149	CC45SL1H220J	C 22pF	
C159	CC45SL1H330J	C 33pF	
C160	CC45SL1H100D	C 10pF $\pm 0.5$ pF	
C162	CC45CH1H010C	C 1pF $\pm 0.25$ pF	
C163	CC45SL1H150J	C 15pF	
C166	CC45SL1H100D	C 10pF $\pm 0.25$ pF	
C167	CC45CH1H020C	C 2pF $\pm 0.25$ pF	
C169	CC45SL1H101J	C 100pF	
C172	C91-0456-05	C 0.047 $\mu$ F	
C173	CC45CH1H010C	C 1pF $\pm 0.25$ pF	
C174	CC45UJ1H680J	C 68pF	
C178.179	CC45SL1H220J	C 22pF	
C182.183	C91-0456-05	C 0.047 $\mu$ F	
C184	CC45CH1H270J	C 27pF	
C185	CC45CH1H390J	C 39pF	
C186	CC45CH1H101J	C 100pF	
C187	CC45SL1H221J	C 220pF	
C188	CC45SL1H220J	C 22pF	
C189	CC45SL1H050C	C 5pF $\pm 0.25$ pF	
C194	CE04W1A470Q	E 47 $\mu$ F 10V	
C196	CC45SL1H100D	C 10pF $\pm 0.5$ pF	
C197~202	C91-0456-05	C 0.047 $\mu$ F	
C205	CE04W1HR47M	E 0.47 $\mu$ F 50V	
TC1	C05-0029-15	Ceramic trimmer 50pF	
TC2.3	C05-0056-05	Ceramic trimmer 30pF	
TC4	C05-0030-15	Ceramic trimmer 20pF	
	E04-0154-05	Coax connector	
	E18-0201-05	Crystal socket	
	E23-0046-04	Square terminal	
T1	L32-0195-05	Oscillating coil 7, 10MHz	
T2	L32-0193-05	Oscillating coil 1.5, 3.5 MHz	
T3	L32-0196-05	Oscillating coil 14 MHz	
T4	L32-0199-05	Oscillating coil 18MHz	
T5	L32-0198-05	Oscillating coil 28MHz	
T6	L32-0197-05	Oscillating coil 21, 24.5MHz	
T7	L34-0714-05	Tuning coil	
T8	L34-0715-05	Tuning coil	

# PARTS LIST

TS-830S, M

Ref No.	Parts No.	Description	Re- marks
T9	L34-0716-05	Tuning coil	
T10	L34-0717-05	Tuning coil	
T11	L34-0718-05	Tuning coil	
T12	L34-0757-05	Tuning coil	
T13	L34-0711-05	Tuning coil	
T14	L34-0713-15	Tuning coil	
T15	L34-0712-05	Tuning coil	
T16	L32-0201-05	Oscillating coil 8.83MHz	
T17	L34-0709-05	Tuning coil 10MHz	
T18	L34-0710-05	Tuning coil 20MHz	
L1~7	L40-1511-03	Ferri-inductor 150 $\mu$ H	
L8	L40-4701-03	Ferri-inductor 47 $\mu$ H	
L9	L40-1592-02	Ferri-inductor 1.5 $\mu$ H	
L10	L40-1092-02	Ferri-inductor 1 $\mu$ H	
L11	L40-1292-02	Ferri-inductor 1.2 $\mu$ H	
L12	L40-1892-02	Ferri-inductor 1.8 $\mu$ H	
L13,14	L40-4711-03	Ferri-inductor 470 $\mu$ H	
L15,16	L40-8201-03	Ferri-inductor 82 $\mu$ H	
L17	L40-1511-03	Ferri-inductor 150 $\mu$ H	
L18~20	L40-2701-03	Ferri-inductor 27 $\mu$ H	
L21~30	L40-1511-03	Ferri-inductor 150 $\mu$ H	
L31	L40-2211-03	Ferri-inductor 220 $\mu$ H	
L32	L33-0636-05	Choke 20 $\mu$ H	☆
L33	L40-2211-03	Ferri-inductor 220 $\mu$ H	
L34,35	L40-4711-03	Ferri-inductor 470 $\mu$ H	
L36	L40-1511-03	Ferri-inductor 150 $\mu$ H	
L37	L40-4711-03	Ferri-inductor 470 $\mu$ H	
L38, 39	L40-1511-03	Ferri-inductor 150 $\mu$ H	
L40	L40-4711-03	Ferri-inductor 470 $\mu$ H	
L41,42	L40-4701-03	Ferri-inductor 47 $\mu$ H	
L43,44	L40-2211-03	Ferri-inductor 220 $\mu$ H	
L45~49	L40-1511-03	Ferri-inductor 150 $\mu$ H	
X1	L77-0482-05	Crystal 10MHz	
X2	L77-0486-05	Crystal 8.8285MHz	
X3	L77-0485-05	Crystal 8.8315MHz	
VR1	R12-5030-05	Trim. pot 100k $\Omega$	
VR2, 3	R12-1040-05	Trim. pot 4.7k $\Omega$	
	R92-0150-05	Short jumper	

## Counter unit (X54-1540-00)

Ref. No.	Parts No.	Description	Re- marks
C1,2	C91-0456-05	C 0.047 $\mu$ F	
C3	CC45SL1H101J	C 100pF	
C4	CC45SL1H470J	C 47pF	
C5	CQ92M1H103K	ML 0.01 $\mu$ F 50V	
C6	CE04W1C470M	E 47 $\mu$ F 16V	
C7	C91-0456-05	C 0.047 $\mu$ F 10V	
C8	CE04W1HR47M	C 0.47 $\mu$ F 50V	
C9	Not used		
C11	CE04W1C101M	E 100 $\mu$ F 16V	
C12	CE04W1V100Q	E 10 $\mu$ F 35V	
C13	CQ92M1H103K	ML 0.01 $\mu$ F 50V	
C14~16	CE04W1V100Q	E 10 $\mu$ F 35V	
C17, 18	C91-0456-05	C 0.047 $\mu$ F	
C19	CQ92M1H103K	ML 0.01 $\mu$ F 50V	
C21,22	CC45SL1H050C	C 5pF $\pm$ 0.25pF	
C23	CE04W1A330Q	E 33 $\mu$ F 10V	
C24	C91-0456-05	C 0.047 $\mu$ F	
C25, 26	C91-0456-05	C 0.047 $\mu$ F	

Ref No.	Parts No.	Description	Re- marks
C27	C91-0456-05	C 0.047 $\mu$ F	
C28	C90-0830-05	E 10 $\mu$ F 50V	
	J31-0502-04	PC board collar	
	J42-0404-05	PC board bush	
T1	L19-0323-05	Oscillating trans	☆
L1	L40-4711-03	Ferri-inductor 470 $\mu$ H	
L2	L40-1011-04	Ferri-inductor 100 $\mu$ H	
L3	L40-2211-03	Ferri-inductor 220 $\mu$ H	
L4	L40-1511-03	Ferri-inductor 150 $\mu$ H	
R10	RC05GF2H221J	Solid 220 $\Omega$ 1/2W	
RB1, 2	R90-0521-05	Resistor block 47k $\Omega$ $\times$ 7	
RB3,4	R90-0522-05	Resistor block 47k $\Omega$ $\times$ 6	
	R92-0150-05	Short jumper	

## AM unit (X54-1610-60) : TS-830M (W)

Ref No.	Parts No.	Description	Re- marks
C5,8	CE04W1H010M	E 1 $\mu$ F 50V	
C6	CE04W1C100M	E 10 $\mu$ F 16V	
	E23-0401-05	Round terminal	
	E40-0373-05	Mini connect wafer 3P	
	E40-0873-05	Mini connect wafer 8P	
T1	L34-2005-05	Tuning coil 455kHz	☆
L1	L40-1021-03	Ferri-inductor 1mH	
	R92-0150-05	Short jumper	
	S51-2408-05	Relay G2V2	

## VFO Ass'y unit (X60-1150-00)

Ref No.	Parts No.	Description	Re- marks
	B07-0630-05	Dial escutcheon	☆
	B10-0632-04	Escutcheon glass	☆
	B20-0815-14	Dial scale (A)	☆
	B20-0816-04	Dial scale (B)	☆
	B30-0819-05	Pilot lamp	☆
	F29-0014-05	Insulating washer	
	G01-0804-04	Coil spring	☆
	K21-0753-04	Main knob	☆
	X40-1170-00	VFO unit	☆

## VFO unit (X40-1170-00)

Ref. No.	Parts No.	Description	Re- marks
	B42-1671-04	Seal	
C2	C91-0456-05	C 0.047 $\mu$ F	
C4	CC45RG1H030C	C 3pF $\pm$ 0.25pF	
C5	CC45PG1H020C	C 2pF $\pm$ 0.25pF	
C6	C91-0456-05	C 0.047 $\mu$ F	
C7	CC45LG1H151J	C 150pF	
C9	CC45LG1H121J	C 120pF	
C12	CC45LG1H680J	C 68pF	

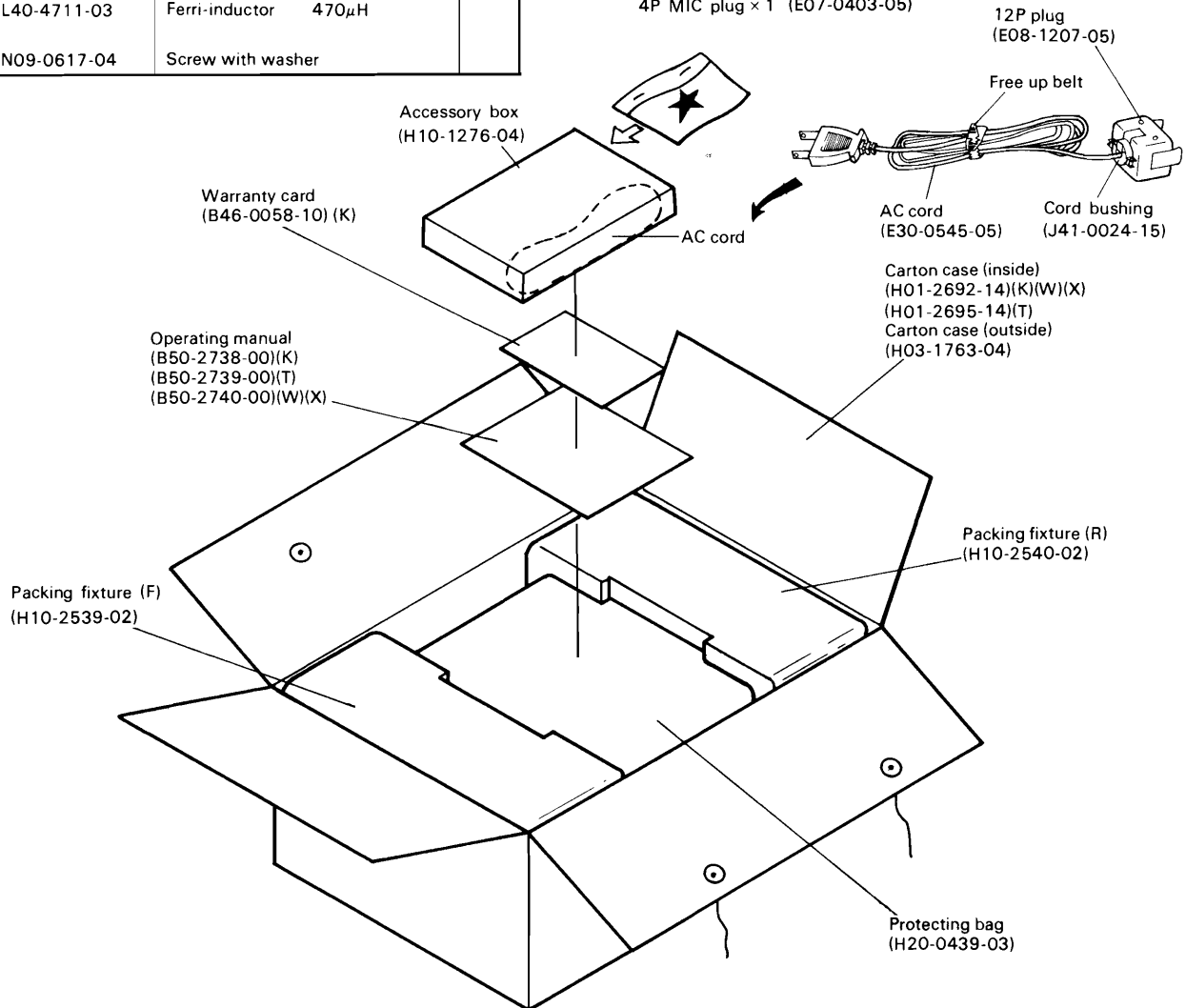
# PARTS LIST/PACKING

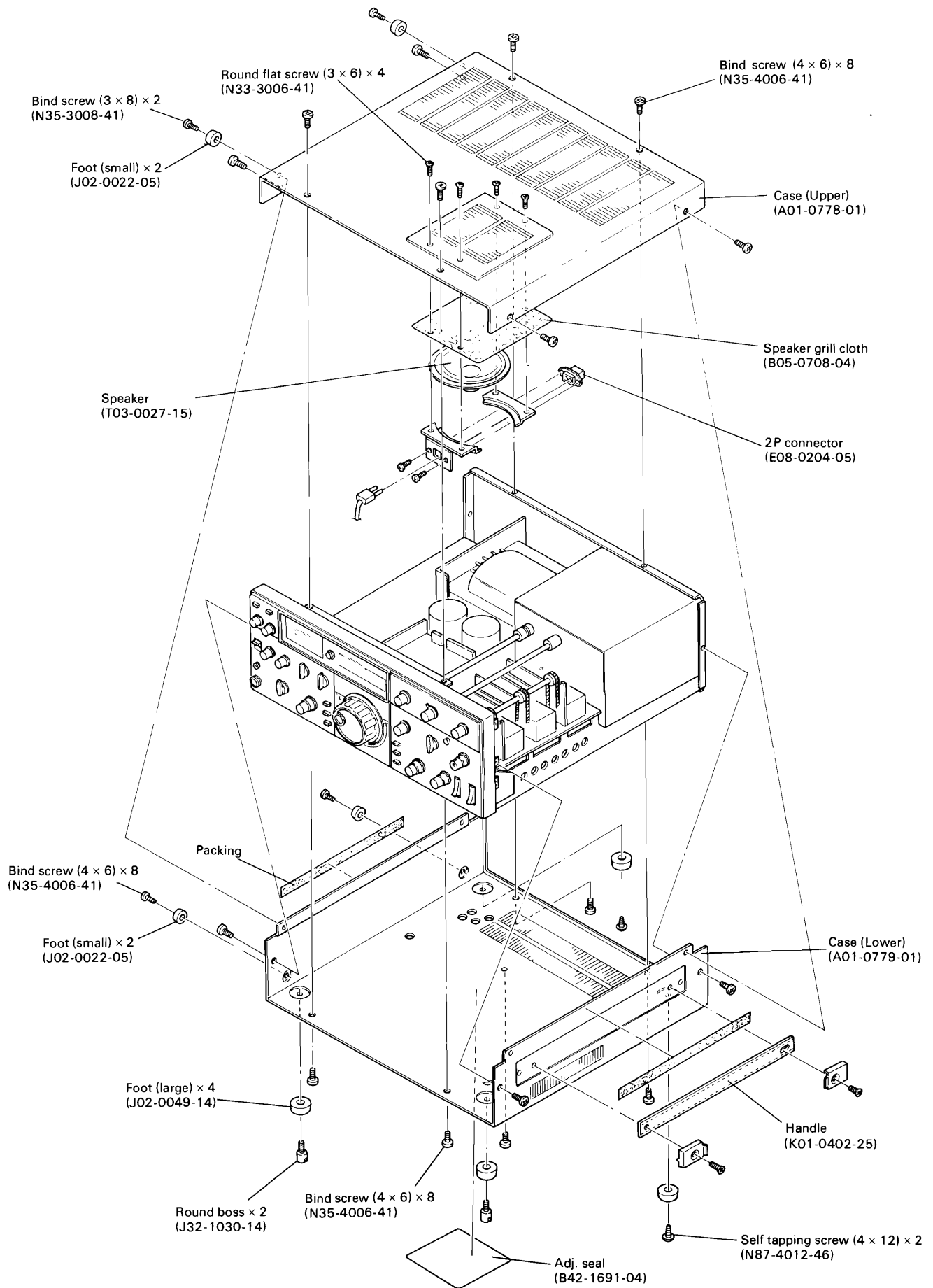
Final unit (X56-1380-00)

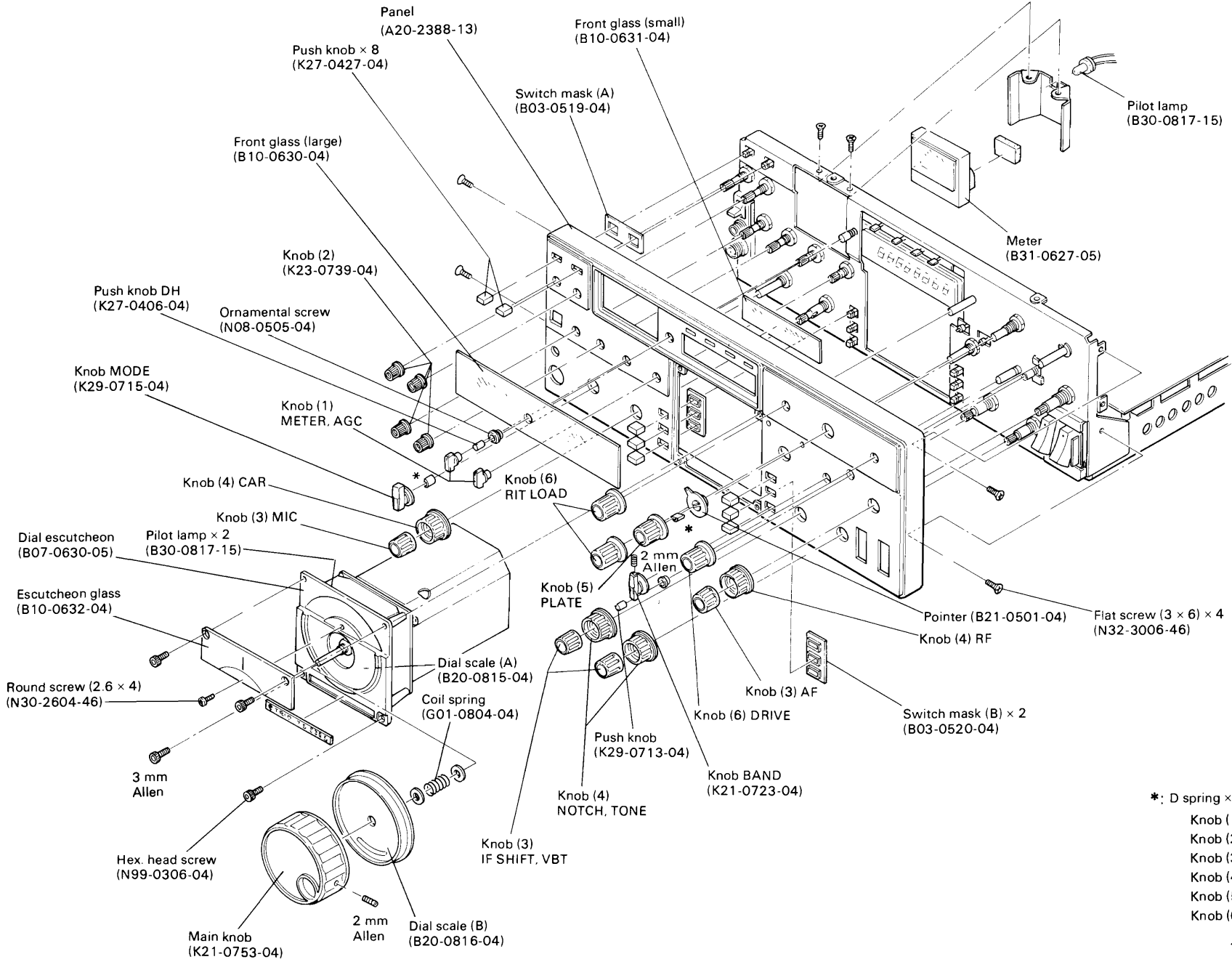
Ref No.	Parts No.	Description	Re- marks
C13	CC45LG1H220J	C 22pF	
C14	CC45CG1H100D	C 10pF ±0.5pF	
C15	CC45LG1H151J	C 150pF	
C16	CC45RG1H151J	C 150pF	
C17	CC45CH1H020C	C 2pF ±0.25pF	
C18	C91-0456-05	C 0.047μF	
C21	CC45SL1H390J	C 39pF	
C22	CC45CH1H100D	C 10pF ±0.5pF	
C23	CC45SL1H390J	C 39pF	
C24	C91-0456-05	C 0.047μF	
VC1	C02-0019-05	Variable capacitor 30pF	☆
TC1	C05-0009-15	Ceramic trimmer 6pF	
TC2	C05-0013-15	Ceramic trimmer 20pF	
	D40-0614-05	Gear ass'y	☆
L1	L32-0628-05	Oscillating coil	☆
L2	L33-0025-05	Choke 1μH	
L3	L32-0629-05	Oscillating coil	☆
L4	L32-0609-05	Oscillating coil	
L5	L40-1021-03	Ferri-inductor 1mH	
L6	L40-4711-03	Ferri-inductor 470μH	
L7	L40-1021-03	Ferri-inductor 1mH	
L8	L40-1501-03	Ferri-inductor 15μH	
L9~11	L40-4711-03	Ferri-inductor 470μH	
	N09-0617-04	Screw with washer	

Ref. No.	Parts No.	Description	Re- marks
C1	CC45SL2H101J	C 100pF 500V	
C2	CK45E2H102P	C 0.001μ 500V	
C11,12	CK45E2H103P	C 0.01μF 500V	
C13	CC45CH2H150J	C 15pF 500V	
	E01-0002-05	8P (octal) socket	☆
	E23-0046-04	Square terminal	
PS1.2	L33-0010-05	Parastic suppressor GRID	
L1	L40-1511-03	Ferri-inductor 150μH	
L2	L40-4711-03	Ferri-inductor 470μH	
R2~5	RC05GF2H200J	Solid 20Ω 1/2W	
R7,8	RC05GF2H101J	Solid 100Ω 1/2W	

- ★ Protective bag (H25-0120-04)
- Fuse (6A) × 1 (F05-6021-05)(K)
- Fuse (4A) × 1 (F05-4022-05)(W)(T)(X)
- Phone plug × 1 (E12-0001-05)
- 7P Din plug × 1 (E07-0751-05)
- Foot (large) × 2 (J02-0049-14)
- Screw (4 × 12) × 2 (N30-4012-46)
- 4P MIC plug × 1 (E07-0403-05)





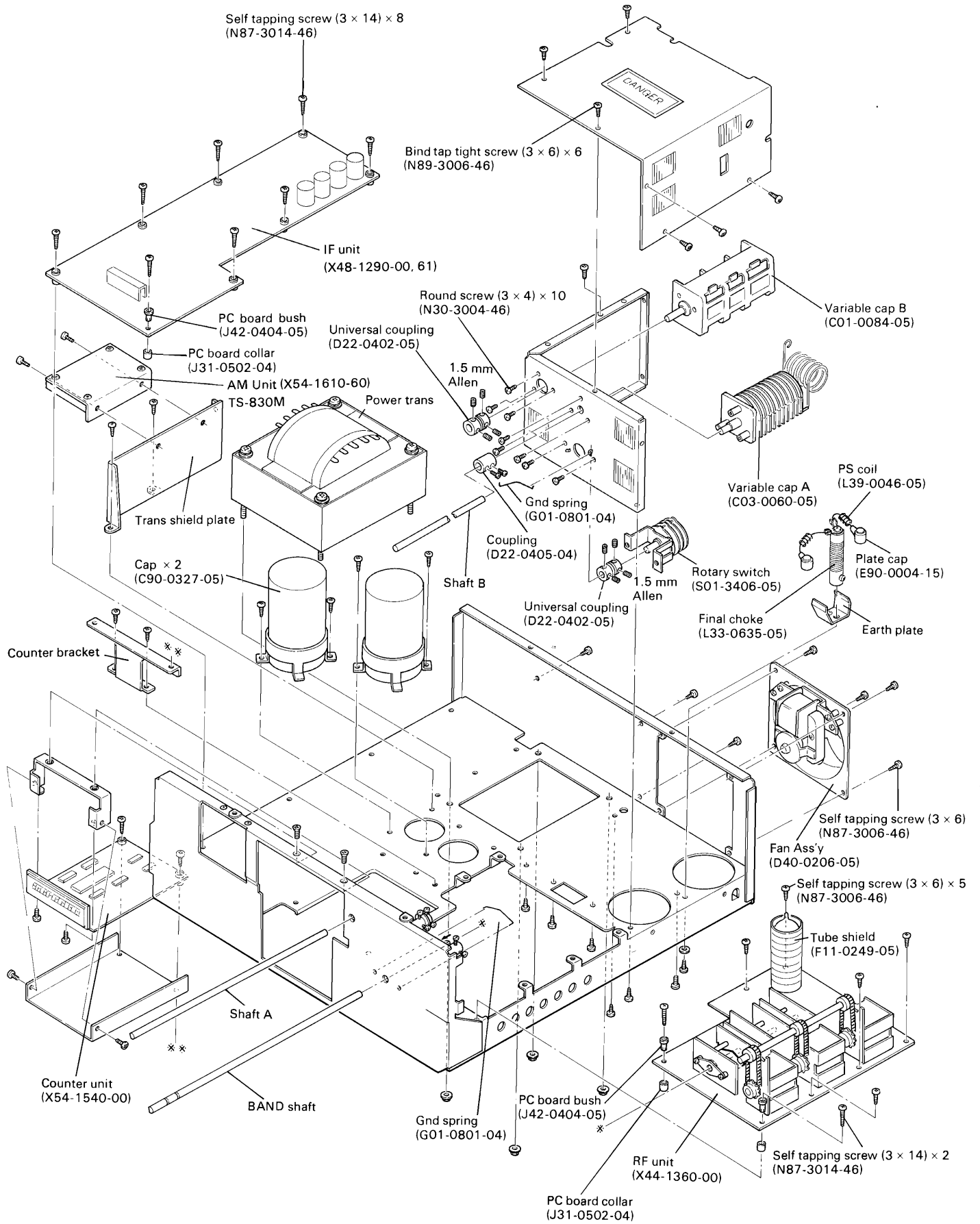


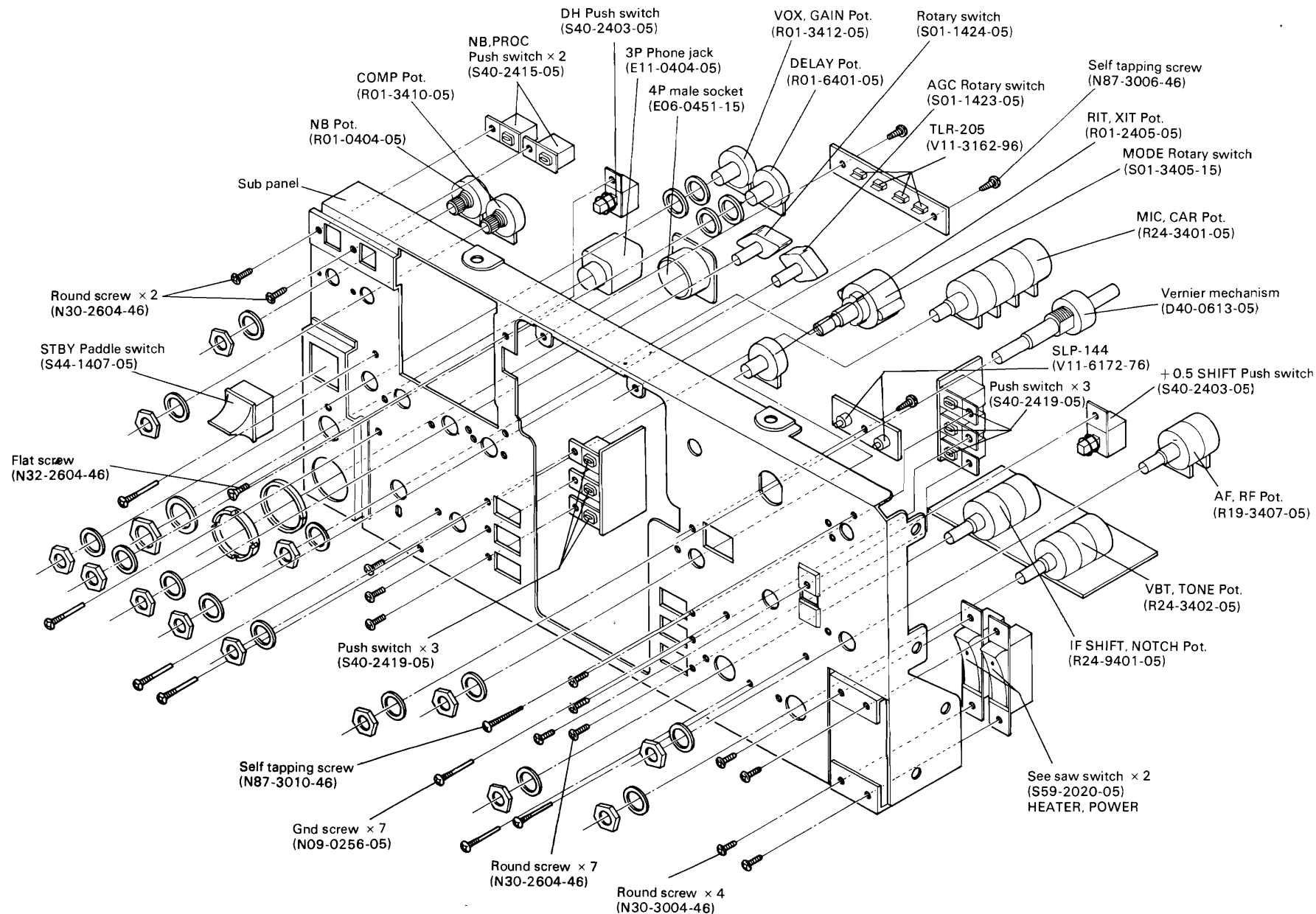
- \*: D spring × 3 (G09-0410-05)
- Knob (1) K23-0738-04
  - Knob (2) K23-0739-04
  - Knob (3) K23-0740-04
  - Knob (4) K29-0736-14
  - Knob (5) K29-0737-04
  - Knob (6) K29-0738-04



# DISASSEMBLY

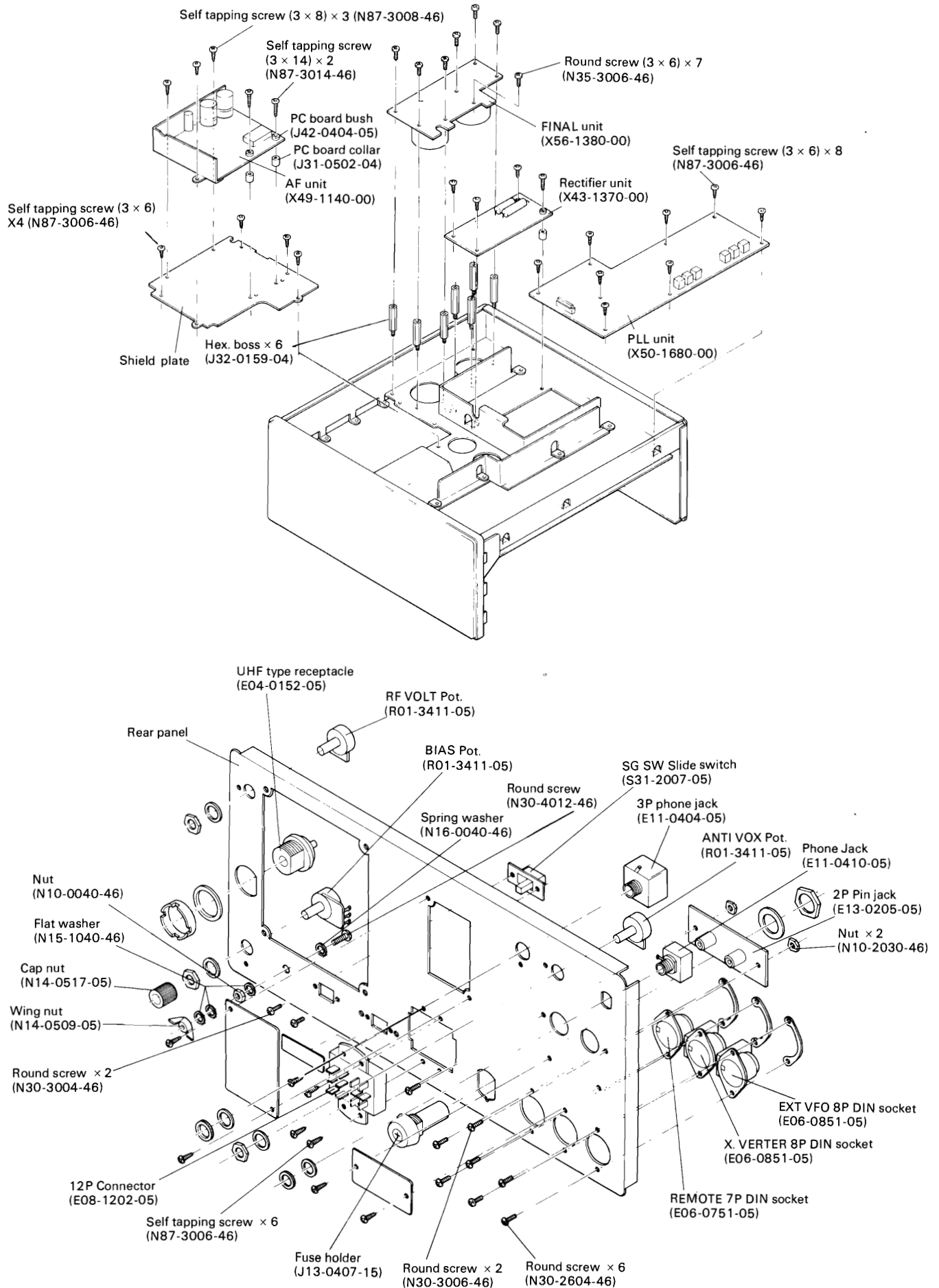
TS-830S, M





# DISASSEMBLY

TS-830S, M



# ADJUSTMENTS

## TEST EQUIPMENT REQUIRED

### 1. VTVM or DVM

- 1) Input resistance More than 1 MΩ
- 2) Voltage range 1.5 to 1000V AC/DC

#### NOTE:

A high-precision voltmeter may be used. However, accurate readings can not be obtained for high-impedance circuits.

### 2. RF VTVM

- 1) Input impedance 1 MΩ and less than 3 pF
- 2) Voltage range 10 mV to 300V
- 3) Frequency range 50 MHz or greater

### 3. AF VTVM

- 1) Frequency range 50 Hz to 10 kHz
- 2) Input impedance 1 MΩ or greater
- 3) Voltage range 10 mV to 30V

### 4. AF GENERATOR (AG)

- 1) Frequency range 200 Hz to 5 kHz
- 2) Output 2 mV~ 1V, low distortion

### 5. AF DUMMY LOAD

- 1) Impedance 8Ω
- 2) Dissipation 3W or greater

### 6. RF DUMMY LOAD

- 1) Impedance 50Ω
- 2) Dissipation 100W continuous or greater
- 3) Frequency limits 1.8 to 30 MHz

### 7. OSCILLOSCOPE

Requires high sensitivity and external synchronization capability

### 8. SWEEP GENERATOR

- 1) Center frequency 8 to 40 MHz
- 2) Sweep bandwidth Maximum ±16 MHz
- 3) Output voltage More than 0.1V

### 9. STANDARD SIGNAL GENERATOR (SSG)

- 1) Frequency range 1.8 to 30 MHz
- 2) Output -20 dB/0.1 μV~120 dB/1V
- 3) Output Z= 50Ω  
Generator must be frequency stable

### 10. FREQUENCY COUNTER

- 1) Minimum input voltage 50 mV
- 2) Frequency range Greater than 50 MHz

### 11. NOISE GENERATOR

Must generate ignition-like noise containing harmonics beyond 30 MHz.

### 12. Spectrum analyzer

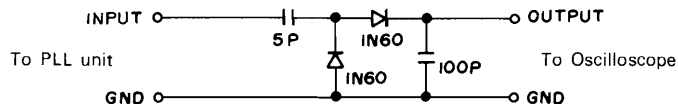
- 1) Frequency range 100 kHz to 110 MHz
- 2) Bandwidth 1 kHz to 3 MHz

#### NOTE:

R-1000 receiver may be used

### 13. Detector

For adjustment of PLL unit BPF



### 14. Directional coupler

### 15. 8P DIN connector

Refer to Fig. 11 on page 41

### 16. FIX-CH Adjusting crystal element

- 1) 5.750 MHz (center 250 kHz)

## PREPARATION

Unless otherwise specified, set the controls as follows.

#### Rear panel

SG SW OFF

#### Front panel

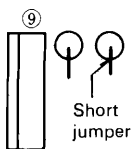
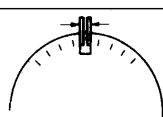
MODE	TUNE	TONE	MAX
CAR	MIN	RF GAIN	MAX
VOX	OFF	PROC	OFF
METER	IP	BAND	1.5
RIT/XIT	CENTERED	DH	OFF
HEATER	OFF	MONI	OFF
FIX	OFF	RIT	OFF
RF ATT	OFF	NOTCH	OFF
XIT	OFF	VBT	MAX
IF SHIFT	CENTERED	AF GAIN	MIN

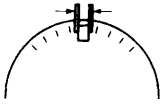
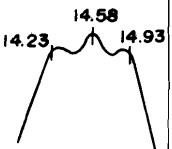
# ADJUSTMENTS

TS-830S, M

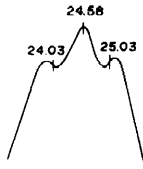
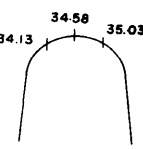
Item	Condition		Measurement			Adjustment			Specification	Remarks
			Test equipment	Unit	Ter- minal	Unit	Parts	Method		
1	9V AVR and 3.6V adjustment		DVM	AF	TP-6 Pin 5, connec- tor ⑨	AF	VR4 VR3	9V 3.6V	9V±0.05V 3.6V±0.05V	RF1
2	Base current adjustment		IP meter							
	SG SW ON MODE USB METER IP HEATER ON FIX ON DRIVE Fully clockwise BIAS VR Rotate							*After checking the above.	Set to 60 mA	
3	Carrier adjustment ①		RF VTVM	IF	TP3	PLL	NOTE: T16	0.3V	0.3V±1dB	NOTE: The slug of T16 should be turned counterclockwise for this adjustment after the peak point is determined.
	IF SHIFT VBT MODE	Centered Fully clockwise USB								
	MODE STBY	LSB REC ↑ SEND	f. counter				VR2	Obtain the same frequency for both transmission and reception.	±20Hz	
	STBY	REC					TC2	8828.50kHz		
	MODE	USB					TC3	8831.50kHz		
	MODE STBY	CW SEND					VR3	8830.70kHz		
	STBY	REC								
4	IF SHIFT check		f. counter	IF	TP3				Set IF SHIFT to center More than + 1 kHz Less than - 1 kHz	
	MODE VBT	LSB Fully clockwise Rotate the IF SHIFT and check the variation								
	MODE	USB Same as above								
	STBY	SEND Regardless of the IF SHIFT setting							8831.50 kHz	USB
	STBY	REC							8828.50 kHz	LSB
	IF SHIFT VBT	Centered Fully counterclockwise							Reference the above frequency Less than - 1 kHz	USB, LSB
5	VBT adjustment and check		RF VTVM	IF	TP1	IF	NOTE: L16	1.0V	1.0V±1dB	NOTE: The slug of L16 should be turned counterclockwise for this adjustment after the peak point is determined.
	VBT	Fully clockwise								
			F.counter				TC2	8375.00kHz		
	VBT	Fully counterclockwise							Reference the above frequency Less than - 2.4 kHz	
	STBY	SEND Regardless of VBT setting							Reference the above frequency Less than ±70 Hz	
	STBY	REC								

# ADJUSTMENTS

Item	Condition		Measurement			Adjustment			Specification	Remarks												
			Test equipment	Unit	Terminal	Unit	Parts	Method														
6 Carrier adjustment②	IF SHIFT	Centered	RF VTVM	IF		IF	L19	Max. level														
	VBT	Fully clockwise																				
	MODE	USB																				
																						
	MODE	LSB																				
	MODE	USB									F.counter											
	MODE	LSB																				
MODE	CW						0.3V±1 dB	If the voltage is outside the specified limit, adjust L19 and L20 until the voltage is 0.3V for both USB and LSB.														
STBY	SEND						456.5 kHz	Reference value														
STBY	REC						453.5 kHz															
							455.7 kHz															
7 VFO, RIT, FIX CH check and adjustment	Scale: 0 ~ 500									Should rotate smoothly and have no abnormal noise.												
	Rear panel VFO	SG SW OFF 250	RF VTVM	PLL	Pin 2, connector ⑤ 1P (GND)	When the voltage is outside specification	VFO TC2	200 mV	200mV±1 dB													
	MODE STBY	CW SEND	F.counter	Rear panel	EXT VFO 1P 7P (GND)	VFO	L4	800 Hz UP	800±50 Hz	CW SHIFT												
	Set the VFO dial to 50. At this time set the CAL control to the index.		F.counter	Rear panel	EXT VFO	VFO	L3		5550.00 kHz ±200 Hz	Repeat the adjustment several times until the frequency is within specification.												
	Set the VFO dial to approx. 450. Set the CAL control dial calibrated under this VFO setting exactly to the index.				1P 7P (GND)		TC1		5950.00 kHz ±200 Hz													
	Tune in 5550.00 kHz with the main tuning knob.								The 50 kHz point on the dial scale must be aligned to the index.													
	Under the above condition, set the CAL control to the index. Turn the main tuning, and set the calibrated CAL control to the index in the order of 0, 100, 200, 300, 400, and 500 to check frequency deviation at each 100 kHz point.							<table border="1"> <tr><td>0</td><td>5.5 MHz</td></tr> <tr><td>100</td><td>5.6</td></tr> <tr><td>200</td><td>5.7</td></tr> <tr><td>300</td><td>5.8</td></tr> <tr><td>400</td><td>5.9</td></tr> <tr><td>500</td><td>6.0</td></tr> </table>	0	5.5 MHz	100	5.6	200	5.7	300	5.8	400	5.9	500	6.0	Within ±2 kHz	Check the scale (Electrically)
	0	5.5 MHz																				
	100	5.6																				
	200	5.7																				
300	5.8																					
400	5.9																					
500	6.0																					
Set the CAL control back to 250 under the above condition (do not turn excessively.), then further set back the CAL control to 0 with respect to the frequency at 250 to check the difference from the reference frequency.								Less than 400Hz	Backlash													

Item	Condition	Measurement			Adjustment			Specification	Remarks				
		Test equipment	Unit	Terminal	Unit	Parts	Method						
	Set point 0 on the dial scale and the CAL control to the index. When the CAL control calibrated at each 100 kHz is set at the index, check the deviation of the dial scale at each point.							Should come in contact with the pointer	Check the scale (mechanically)				
	RIT: Centered RIT switch: ON Set the VFO main control to 5750.000 kHz				AF	VR2	5750.000 kHz						
	Check that the same frequency is obtained when the RIT switch is turned ON and OFF.							Less than 50 Hz					
	RIT switch: ON  VFO: 250 RIT control: fully counter-clockwise (⊖ position) RIT control: fully clockwise (⊕ position)							- 1.5kHz or less + 1.5kHz or more Reference to the center (ϕ) position of the RIT control.					
	RIT OFF												
	Install the 5750 kHz quartz crystal into the socket on the PLL unit.				PLL	TC4	Centered	Normal oscillation must be obtained.					
							TC 4 Variable	Variable range: ±250 Hz					
	FIX ON	RF VTVM					Centered	Output level 0.2V ± 2 dB					
	Remove the quartz crystal from its socket. FIX OFF												
8. Counter reference oscillator adjustment		F.counter	PLL	TP2	PLL	TC1	1000.000 kHz						
9. VCO adjustment and check	Check the frequencies at the following points and adjust coils until those given in brackets are obtained.	F.counter DVM	RF(PLL) PLL	TP3(D40) TP1	Adjusting point								
											Unit	Part	
					VFO BAND	0	250	500			PLL	T2	
					1 5	10.33 MHz	10.58 MHz (4.0V)	10.83 MHz					
					3 5	12.33	12.58	12.83					T1
					7	15.83	16.08 (4.75)	16.33					
					10	18.83	19.08	19.33					T3
					14	22.83	23.08 (4.5)	23.33					
					18	26.83	27.08 (5.0)	27.33					T4
					21	29.83	30.08 (3.5)	30.33					
					24 5	33.33	33.58	33.83					
					28	36.83	37.08	37.33					T5
					28 5	37.33	37.58	37.83 (4.75)					
					29	37.83	38.08	38.33					
29 5	38.33	38.58	38.83										
	Check the level at each of the above points.	RF VTVM	RF	TP3				1V <sup>+3</sup> dB -2					
	Both edges of the VFO frequency in each band							Display should indicate.					
10. BPF-A	Disconnect connectors ① and ⑤ on the PLL unit. Connect the cathode of D24 (1S1555) to the jumper wire next to R44 with a clip lead. Connect the sweep generator RF output to the EXT-VFO connector.	Sweep generator, Oscilloscope	PLL	Q35 ⑥	PLL	T13 T14 T15	Adjust until the response shown to the right is obtained.						

# ADJUSTMENTS

Item	Condition	Measurement			Adjustment			Specification	Remarks
		Test equipment	Unit	Terminal	Unit	Parts	Method		
11. BPF-B adjustment	Disconnect connectors ① and ⑤ on the PLL unit. Connect the cathode of D27 (1S1555) to the jumper wire next to R44 with a clip lead. Connect the cathode of D50 (1S1587) to the jumper wire next to TC1 with a clip lead. Connect the RF output of the sweep generator to R111 (100Ω) via a 15PF capacitor	Sweep generator Oscilloscope	PLL	Q35 (E)	PLL	T7 T8 T9 T17	Adjust T7 ~ T9 until the response shown at the right is obtained. Then adjust T17 for maximum amplitude.		
12. BPF-C adjustment	Disconnect connectors ① and ⑤ on the PLL unit. Connect the cathode of D26 (1S1555) to the jumper wire next to R44 with a clip lead. Connect the cathode of D50 (1S1587) to the jumper wire next to TC1 with a clip lead.					T10 T11 T12  T18	Adjust T10 through T12 until the band response shown at right is obtained. Then adjust T18 for maximum amplitude.		
13. VFO MIX spurious adjustment NOTE: This adjustment should be done after completing the adjustment (or check) of BPF-A.	Disconnect connector ① on the PLL unit. Connect the cathode of D24 (1S1555) to the jumper wire next to R44 with a clip lead. VFO 250 MODE CW	Spectrum analyzer (Monitor receiver)				VR1	Minimum (14.99 MHz)	Less than -55dB	
13' Balance adjustment  TS-830M only	BAND: 7 VFO: 150 MODE: AM  Connect the SSG output (7.15 MHz, 10dB) to the ANT terminal.	Oscilloscope, AF VTVM	Rear panel	EXT SP	RF  IF	VR1  VR9	Beat output for minimum		TS-830M only
14. Carrier balance adjustment	IF SHIFT Centered RF GAIN Fully counterclockwise	RF VTVM	Rear panel	IF OUT 2	IF	TC1	Minimum		
15. IF AMP adjustment	BAND: 1.5 VFO: 400 DRIVE: 12 00 RF GAIN: fully clockwise IF SHIFT: centered RF ATT: OFF MODE: USB AGC: OFF NOTCH SW: OFF NB SW: OFF	AF VTVM Oscilloscope	Rear panel	EXT SP	RF	ANT coil 1.8 RF coil 1.8  T2	Max. audio output		
	VBT: fully clockwise TONE: fully clockwise SG SW: OFF Connect the SSG output (1.9 MHz, 40 dB) to the antenna terminal. While adjusting, gradually decrease the SSG output level down to -6 dB.				IF	L2 ✓ L3 ✓ L4 ✓ L5 ✓ L6 ✓ L7 ✓ L9 ✓ L11			
16. Coil pack adjustment	Connect the SSG (40 dB) to the ANT terminal. DRIVE 12:00 While adjusting, gradually decrease the SSG output level down to -6 dB. Adjust at the following points:	AF VTVM Oscilloscope	Rear panel	EXT SP	RF	ANT coil RF coil	Max. audio output		
	No. BAND VFO f								
	1 1.5 400 1.9 MHz						1.8		
	2 3.5 250 3.75						3.5		
	3 7 150 7.15						7		
	4 10 125 10.125						10		
5 14 175 14.175						14			



# ADJUSTMENTS

TS-830S, M

Item	Condition				Measurement			Adjustment			Specification	Remarks			
					Test equipment	Unit	Terminal	Unit	Parts	Method					
	6	18	125	18.125					18						
	7	21	225	21.225					21						
	8	24.5	450	24.950					24						
	9	28.5	300	28.800					28						
17 ALC "0" adjustment	METER ALC							IF	VR6	ALC meter starting point					
18. Generator, Drive coil adjustment	CAL	ON						RF	DRIVE coil	Max. ALC meter reading					
	CAR VR	Centered													
	HEATER	ON													
	MODE	CW													
	METER	ALC													
	SG SW	OFF													
	RF ATT	ON													
	Receive the marker frequency in the following bands and obtain the peak level by adjusting the DRIVE control. Set the STBY switch to SEND and adjust each coil.														
	BAND	VFO													
	1.5	400									1.8				
	3.5	250									3.5				
	7	150									7				
(10)	(125)							10							
14	175							14							
(18)	(125)							18							
21	225							21							
(24.5)	(450)							24.5							
28.5	300							28							
	BAND 14, VFO 175 Adjust the CAR control until the ALC meter reads maximum.							RF IF	T4 L24 L25 L28 L29	Max. ALC meter reading					
	STBY REC														
18' AM adjustment and S/N check  TS-830 M only	BAND: 14 VFO: 175 MODE: AM  Connect the SSG output (14.175MHz, 40dB, MOD: 1kHz, 30%) to the ANT terminal.				AF VTVM, Oscilloscope	Rear Panel	EXT. SP	AM	T <sub>1</sub>	Max. audio output		TS-830 M only			
	SSG Output: 12 dB TONE: Centered									Adjust the DRIVE Control for max. AF Output. Set to 0.63V/8Ω with AF GAIN Control.					
	SSG MOD: OFF										Less than 0.2V/8Ω (S/N more than 10 dB)				
19. MIX balance adjustment	RF ATT ON BAND 1.5 VFO 0				Oscilloscope	Rear panel	IF OUT 1	RF	VR1	Minimum		Except TS-830M			
20. IF trap adjustment	BAND: Between 1.5 and Aux. Connect the SSG (8.83 MHz, 80 dB) to the ANT terminal.				Oscilloscope AF VTVM	Rear panel	EXT. SP	RF	L22 L3 L4	Minimum Adjust in the order of L22 ~ L4.		Preset the slugs of L3 and L4 fully clockwise.			
21 S meter adjustment	AGC OFF							IF	VR2	Set to the deflection starting point					
	BAND 14 VFO 175 AGC FAST  Connect the SSG (14.174 MHz, 8dB) to the ANT terminal				Oscilloscope AF VTVM	Rear panel	EXT SP			Adjust the DRIVE control for maximum AF output.					

( ): See note **Before** adjustment  
Note:

### TRANSMITTING ON WARC BANDS

As supplied, the TS-830S will receive but not transmit on the 3 new WARC bands. If transmit capability is desired, a minor wiring change is required.

1 For all 3 bands: Break the line between the RF unit X44-1360-00, connector #6, Pin #1 (TOF terminal) and AF unit X49-1140-00, connector #6, Pin #4 (TOF terminal).

2 Or, for individual Bands. On the RF unit X44-1360-00.

Band	Remove (or Cut) Part
10 MHz	D4
18 MHz	D5
24.5 MHz	D6

# ADJUSTMENTS

Item	Condition	Measurement			Adjustment			Specification	Remarks
		Test equipment	Unit	Terminal	Unit	Parts	Method		
					IF	L9	Turn the coil slug counterclockwise until S-1 is obtained.		
	SSG output: 40 dB * Repeat S-1, 9 adjustment several times.					VR3	Set to S-9		
22. NB adjustment	NB LEVEL. fully counterclockwise BAND 14, VFO: 175 Connect the SSG output (14.175 MHz, 60 dB) to the ANT terminal.	DVM	AF	TP4	AF	T1 T2	Minimum		
	SSG output: 20 dB Adjust as described above.								
	AGC FAST  Disconnect the SSG output from the ANT terminal, and connect the noise generator output in it's place. Set the noise generator output level to S5 ~ 7	Speaker	Rear panel	EXT. SP					
	NB ON							The NB must provide adequate effect.	
								If adequate effect is not obtained, repeat the adjustment several times.	
	Reduce the noise generator output level to below the threshold of sensitivity Turn the NB LEVEL control fully clockwise.							Noise must be blanked.	
	NB OFF								
23. VBT adjustment with VBT-1	MODE CW.N IF SHIFT Centered VBT Fully clockwise  Disconnect connector ⑩ on the IF unit. Connect the VBT-1 output to IF OUT 1, and connect the oscilloscope to IF OUT 2. Connect a 0.047μF capacitor across D14 and D15 on the IF unit. Set the filter switching terminal connection to CW3. Adjust the control on the VBT-1 until the waveform shown at right is observed on the oscilloscope.	Oscilloscope VBT-1		IF OUT 1, 2					This adjustment requires the use of the VBT-1. If the VBT-1 is unavailable, this adjustment will be difficult.
	Set the MODE switch to CW.W.				IF	TC2	Adjust until the waveform shown in the preceding item is obtained.		
	Remove 0.047 μF capacitor Reconnect connector ⑩								
23' VBT adjustment with SSG, AG and Oscilloscope	BAND: 1.5 MODE: CW.N IF SHIFT Centered VBT Fully clockwise  Disconnect connector ⑩ on the IF unit. Connect a 0.047 μF capacitor across D14 and D15 on the IF unit. Filter SW terminal: CW3 Receive SSG signal (1.9 MHz, 60 dB), and set the main tuning to obtain waveform shown at right. MODE: CW.W	SSG, AG, Oscilloscope	Rear panel	IF OUT 2	IF	TC2	Adjust TC2 until part A becomes null.		<p><math>f = 1.2 \text{ kHz}</math> Level: Level for max. AM modulation.</p>
	Filter SW terminal: CW1								

# ADJUSTMENTS

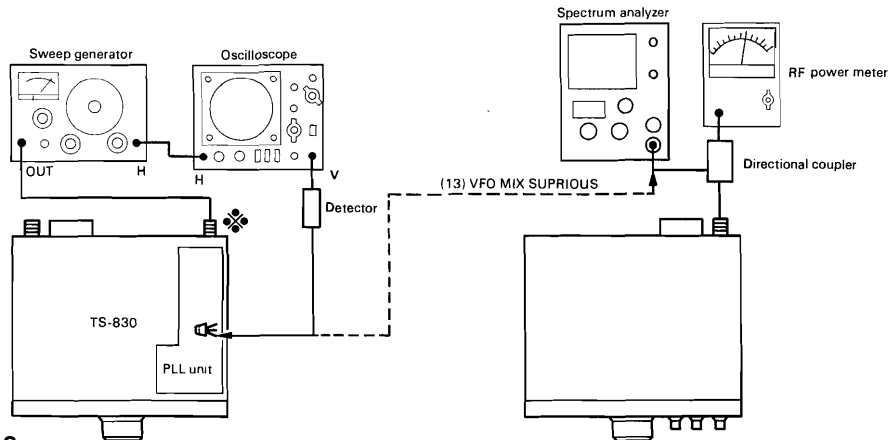
TS-830S, M

Item	Condition	Measurement			Adjustment			Specification	Remarks
		Test equipment	Unit	Terminal	Unit	Parts	Method		
24. NOTCH adjustment	NOTCH OFF BAND 1.5 VFO 400 AGC FAST NOTCH Centered Turn VR1 on the IF unit fully counterclockwise. Couple the SSG output (1.9 MHz, 40 dB) to the ANT terminal.	Oscilloscope AF VTVM F.counter	Rear panel	EXT SP			Set beat frequency to 1500 Hz and audio level 0.63V/8Ω.		
	NOTCH ON				IF	L10 VR1	Min. audio level	*Repeat a few times	
	Rotate NOTCH.							The dip point should be located somewhere between 11:00 to 1:00, and audio level 0.1V/8Ω or less.	
	NOTCH OFF								
25. Neutralization trimmer adjustment	BAND 28, + 0.5 SHIFT ON VFO 300 SG SW ON STBY SEND Tune the DRIVE, PLATE and LOAD	Power meter Sync'd scope	Rear panel	ANT					
	SG SW OFF							The output must be 0.	
	Set the ALC to maximum with the DRIVE control. Increase oscilloscope sensitivity.					Neutrazation trimmer TC1	Minimum		
	Reduce oscilloscope sensitivity (5V/div.). SG SW ON							The normal power must be obtained. The signal waveform must be normal.	
26. Side tone semi-break-in function adjustment	Connect a power meter to the ANT terminal. Plug key into the rear Key jack to transmit in any band.	Oscilloscope AF VTVM	Rear panel	EXT SP	AF	VR1	0.63V/8Ω		
	Operate the key							The power must be intermittant.	
	STBY REC VOX ON Operated the key.							Semi-break-in operation should be available.	
27. Transmission spurious adjustment	Ground pin 4 of connector ⑥ on the AF unit. Set the BAND switch to 18 and VFO to 125. Connect a power meter to the ANT terminal. Set the STBY switch to SEND and tune up.	Spectrum analyzer (receive 17.66MHz with a monitor receiver.)	Rear panel	ANT	RF	VR2	Minimum (Monitor level)	Less than -40 dB	
	STBY REC								
28. RF meter adjustment	BAND 14 VFO 175 METER RF Connect a power meter to the ANT terminal. Tune up.				Rear panel	RF VOLT	Set the IP meter reading to 250.		
	STBY REC								
29. Carrier suppression adjustment	BAND 14 VFO 175 MODE CW Connect power meter to ANT. STBY SEND Tune up.	Sync'ro scope	Rear panel	ANT	IF	VR4 TC3	Adjust alternately until the minimum point is obtained.		
	MODE USB ↓ MODE LSB						Adjust until no level difference exists between LSB and USB.		

# ADJUSTMENTS

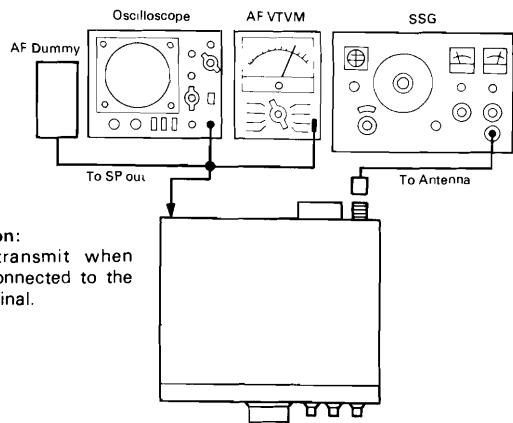
Item	Condition	Measurement			Adjustment			Specification	Remarks
		Test equipment	Unit	Terminal	Unit	Parts	Method		
	MODE CW Sync'ed scope level calibration								
	MODE USB, LSB							Less than - 50 dB	Compare with CW
	STBY REC								
30. SSB frequency response adjustment	BAND 14 VFO 175 MODE USB Connect the AG (1500Hz, 7mV) to the MIC input connector STBY SEND Tune up. Set to 50W with MIC GAIN control.	Power meter Sync'ed scope	Rear panel	ANT					
	AG 300Hz ↓ 2700Hz				PLL	TC3	Adjust until the same level is obtained for both 300 Hz and 2700Hz (equal audio rolloff).		
	MODE LSB same as above					TC2			
	AG 400Hz AG 2600 Hz							More than 1/2 with respect to the 1500Hz signal level observed on the scope.	
	After completing the above adjustment, readjust the carrier suppression (see item 29.)				IF	VR4 TC3	Minimum	Less than -50dB	
31 ALC adjustment	BAND 14, VFO 175 MIC GAIN MIN METER ALC Connect power meter to the ANT terminal. STBY SEND				(When misaligned.) IF	VR6	Set to the deflection start point.	The ALC meter must be aligned to its exact zero point.	
	Connect an AG output (1.5 kHz, 5 mV) to the MIC jack. Set the MIC GAIN control to maximum. Tune up. Reduce the power by 5 watts with the MIC GAIN control.							No ALC deflection	
	Increase the AG output to 10 mV.				IF	VR7	Obtain the maximum ALC on-scale reading.		
	Repeat the above three adjustment steps several times.								
32. Speech processor adjustment	SG SW OFF MODE USB METER COMP MIC GAIN MIN PROC ON Connect the AG output (1.5 kHz, 5 mV) to the MIC jack. Set the STBY switch to SEND. Adjust the COMP LEVEL control until the meter reading is obtained.				IF	L26	Max. meter reading		
	Set VR5 on the IF unit fully clockwise. Adjust the COMP LEVEL control until the meter indicates S-1. Set the AG output to 50 mV.					VR5	Meter indicator 20 dB		
	METER ALC Adjust the MIC GAIN control until the maximum meter reading is obtained.					L27	Max. meter reading		

Item	Condition	Measurement			Adjustment			Specification	Remarks
		Test equipment	Unit	Terminal	Unit	Parts	Method		
	Set the PROC to OFF and the COMP LEVEL control to maximum. Set the AG output to 10 mV. Adjust the MIC GAIN control until the meter indicates the maximum on-scale ALC reading. Set the PROC to ON.					L27	Adjust until the same meter reading is obtained (MAX ALC on-scale).	MIC input providing the same ALC meter reading: 10mV±3 dB	NOTE: L27 should be adjusted while it is turned counterclockwise.
	STBY REC								
33. Monitor level adjustment	BAND 14 VFO 175 AGC FAST CAL ON Set the marker level to 0.63V with the AF GAIN control.	Oscilloscope	Rear panel	EXT. SP					
	Connect a power meter to the ANT terminal. SG SW ON STBY SEND Tune up MODE USB Connect the AG (1 kHz, 10 mV) to the MIC jack. METER ALC Deflect ALC meter by MIC GAIN control. MONI ON				IF	VR8	Monitor output 0.63V/8Ω.		
	Disconnect AG. AF GAIN MAX.							Less than 8mV/8Ω	Monitor hum
	MONI OFF, STBY REC								

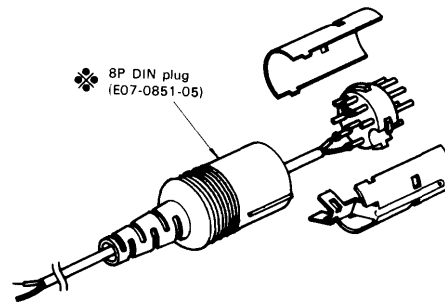


**Fig. 9**  
 (10) BPF-A, (11) BPF-B, (12) BPF-C  
 (13) VFO MIX SPURIOUS

**Fig. 10 (27) TX SPURIOUS**



☆ **Caution:**  
**NEVER** transmit when SSG is connected to the ANT terminal.

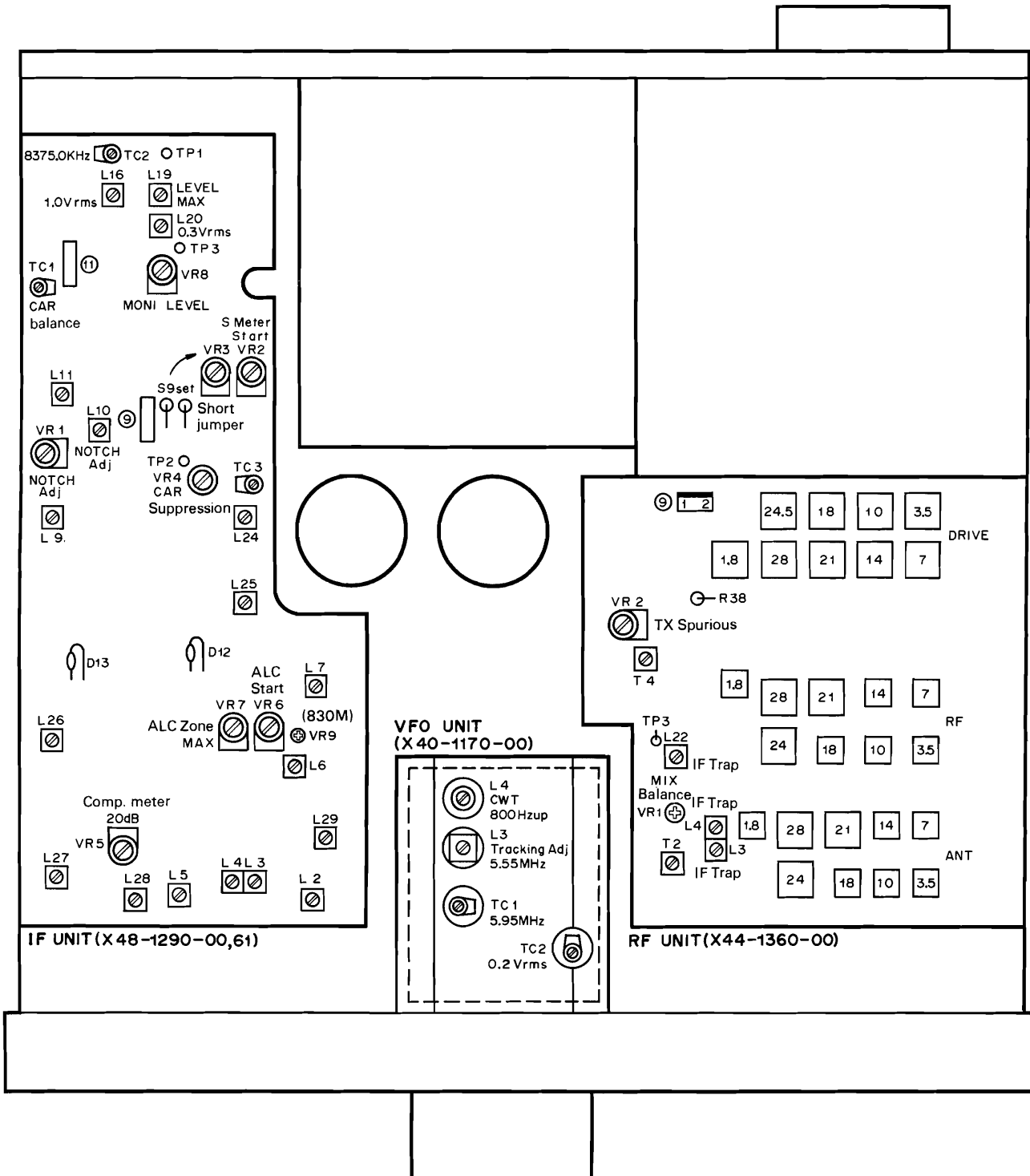


**Fig. 11 8P DIN connector**

**Fig. 12 (15) IF AMP, (16) COIL PACK, (20) IF TRAP,**

# LOCATION OF ADJUSTMENTS

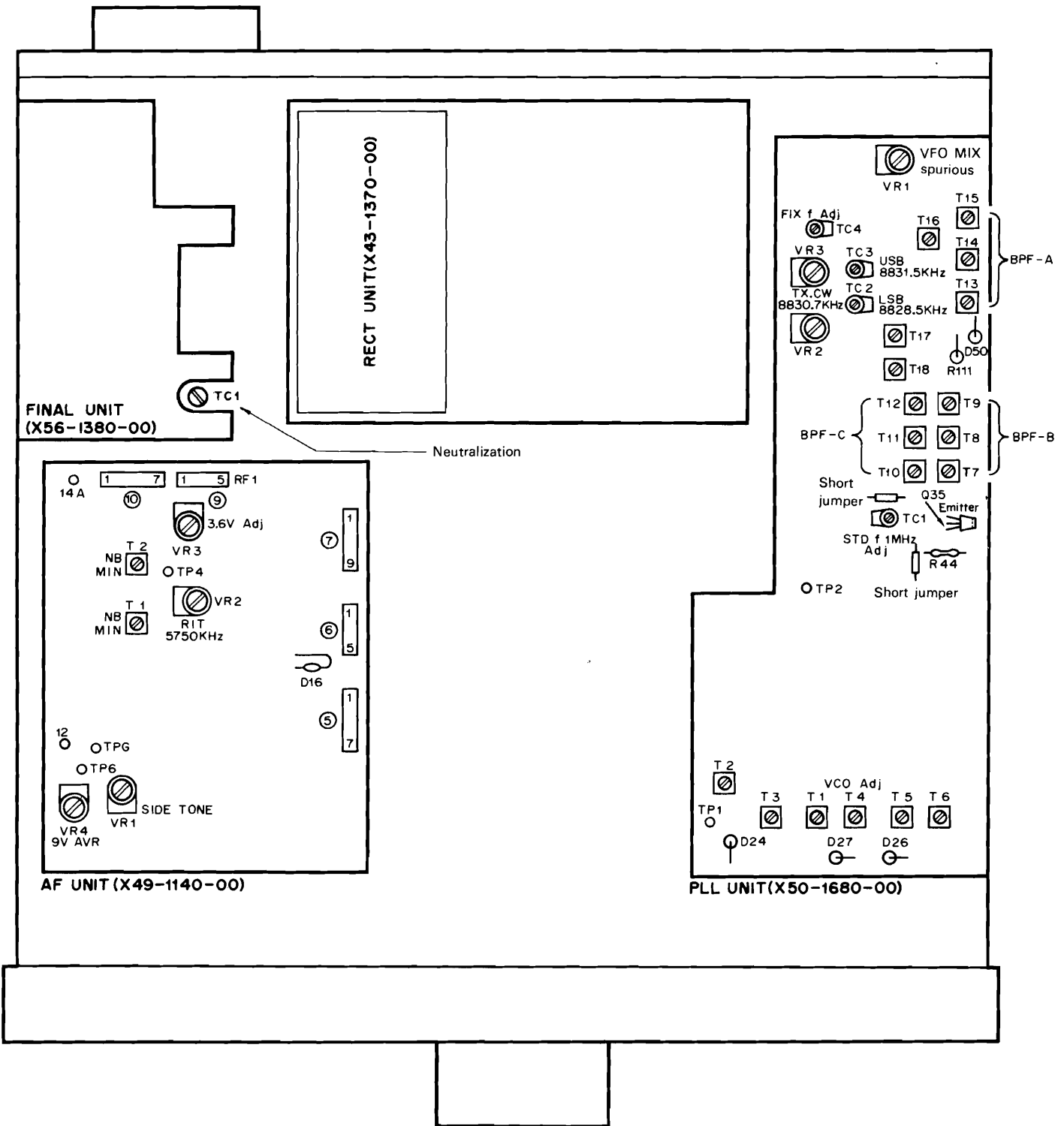
▼ TOP VIEW



# LOCATION OF ADJUSTMENTS

TS-830S, M

▼ BOTTOM VIEW

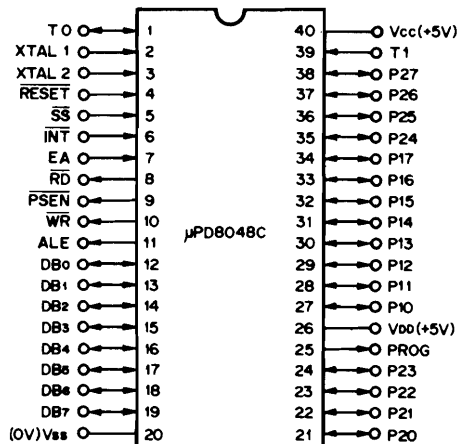
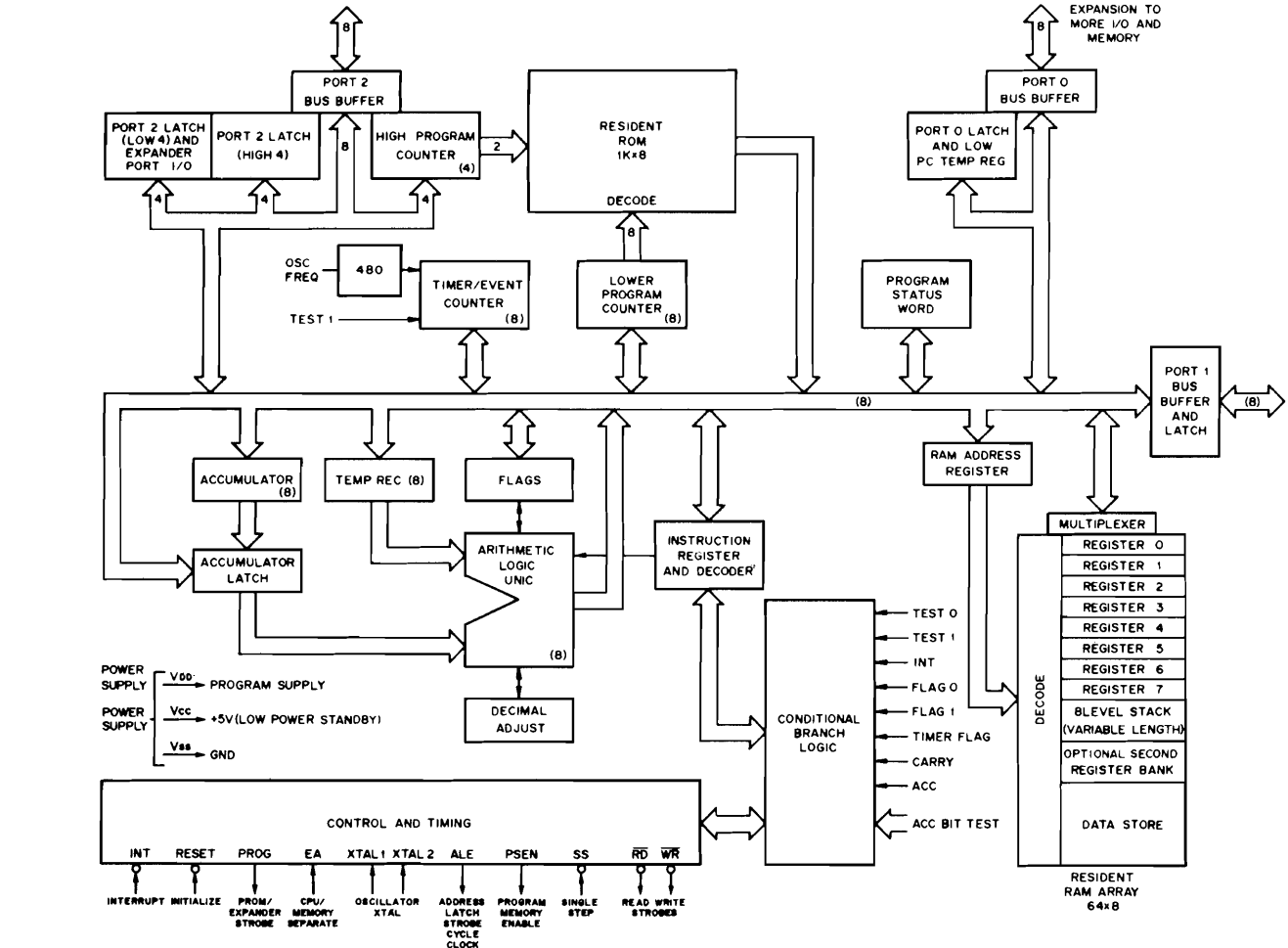


# VFO-230

The frequency display resolution is identical to that of the main unit (down to 100 Hz) except for the RIT and CW transmission frequency display. This is accomplished by dynamically driving the fluorescent display tube based on the display and column data furnished by the microprocessor. The power to the VFO-230 is interlocked with that of the main unit. If, however, the VFO-230 is plugged into an AC outlet, the display, memory and output of the VFO remain live even when the power switch on the main unit is OFF. Therefore, when the main unit is again powered-on, the operating state set prior to power-off will reappear. Back-up power consumption for the VFO-230 is approximately 10 mA at 5V.

Item	Rating
Center frequency	470 kHz
6 dB bandwidth	± 12.5 kHz or more
50 dB bandwidth	± 25 kHz or less
Ripple (within 455 ± 8 kHz)	3 dB or less
Loss	4 dB or less
Guaranteed attenuation	35 dB or less within 455 ± 100 kHz
Input and output impedance	1.5 kΩ

Fig. 11 Ceramic filter (L71-0321-05) CFW470C (DIGITAL UNIT, CF 1)



- Terminals**
- P10 ~ P17 Input and output port (PORT 1)
  - P20 ~ P27 Input and output port (PORT 2)
  - DB<sub>0</sub> ~ DB<sub>7</sub> Data bus
  - T0, T1 Test
  - INT Interrupt
  - RD Read
  - WR Write
  - ALE Address latch enable
  - PSEN Program store enable
  - RESET Reset
  - SS Single step
  - EA External access
  - XTAL 1, 2 Crystal input

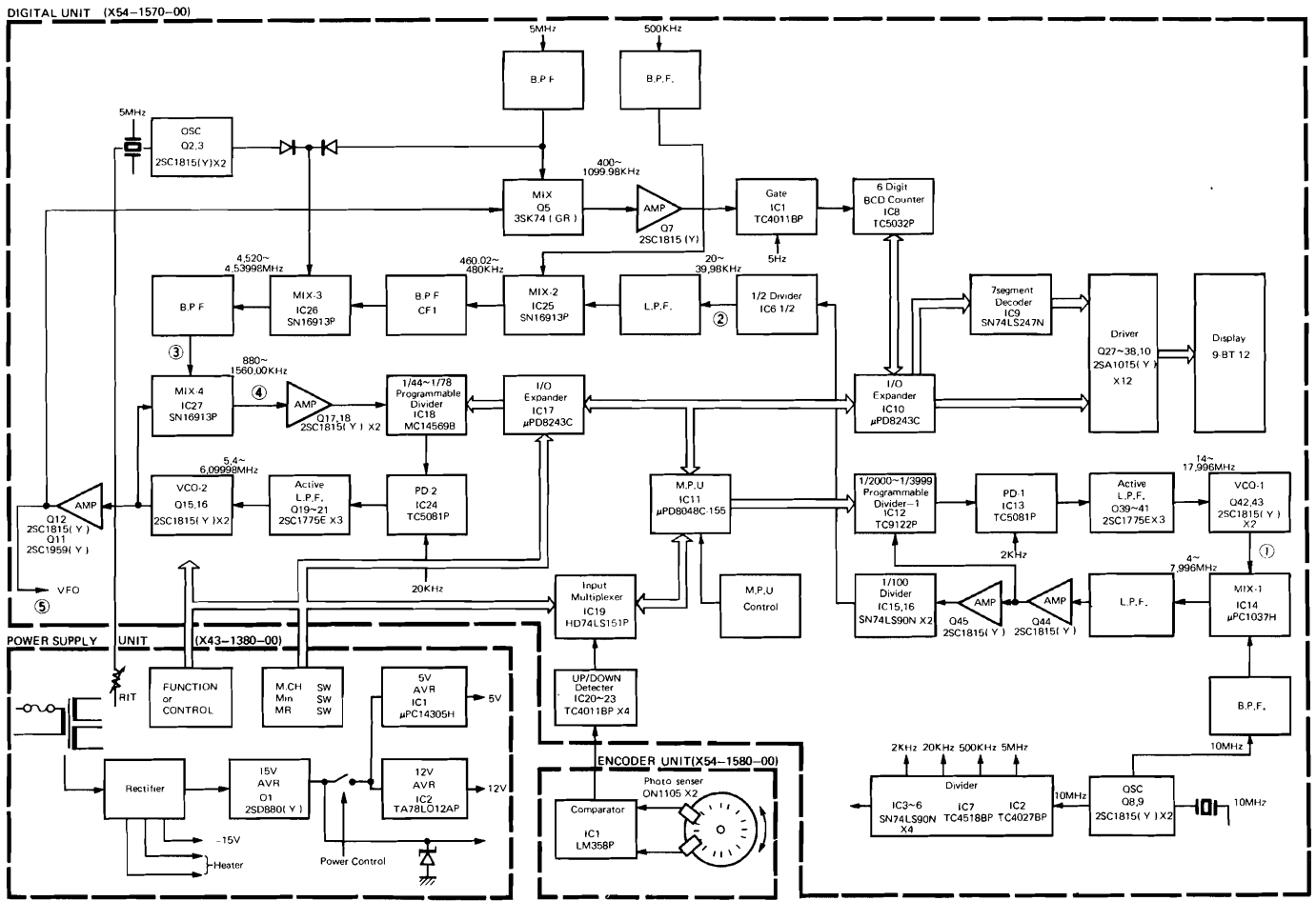
**Maximum rating (Ta = 25°C)**

Item	Symbol	Rating
Operating voltage	V <sub>CC</sub>	-0.5 ~ +7.0V
	V <sub>DD</sub>	-0.5 ~ +7.0V
Input voltage	V <sub>i</sub>	-0.5 ~ +7.0V
Output voltage	V <sub>o</sub>	-0.5 ~ +7.0V
Operating temperature	T <sub>opt</sub>	0 ~ +70°C
Storage temperature	T <sub>stg</sub>	-65 ~ +150°C

Fig. 13 μPD8048C-155 (DIGITAL UNIT, IC11)



# VFO-230



VFO-230 BLOCK DIAGRAM

Refer to Block Diagram

Display f. (kHz)	VFO f. (MHz) ⑤	IC12 14 Bit BCD data (I/M)	Q42VCO f. (MHz) ①	IC6 (Pin 12) output f. (kHz) ②	IC27 (Pin 5) input f. (kHz) ③	IC18 7 Bit binary (I/N)	IC27 output f. (kHz) ④
		M				N B <sub>3</sub> B <sub>2</sub> B <sub>1</sub> A <sub>4</sub> A <sub>3</sub> A <sub>2</sub> A <sub>1</sub>	
L. 900.0	5,400.00	2 0 0 0	14.000	20.00	4520.00	44 0 1 0 1 1 0 0 0	880
L. 900.0	5,400.02	2 0 0 2	14.004	20.02	4520.02	44 0 1 0 1 1 0 0 0	880
...	...	...	...	...	...	...	...
L. 900.1	5,400.10	2 0 1 0	14.020	20.10	4520.10	44 0 1 0 1 1 0 0 0	880
...	...	...	...	...	...	...	...
L. 900.8	5,401.60	2 0 8 0	14.160	20.80	4520.80	44 0 1 0 1 1 0 0 0	880
...	...	...	...	...	...	...	...
L. 901.0	5,401.00	2 1 0 0	14.200	21.00	4521.00	44 0 1 0 1 1 0 0 0	880
...	...	...	...	...	...	...	...
L. 909.9	5,409.98	2 9 9 8	15.896	29.98	4529.98	44 0 1 0 1 1 0 0 0	880
...	...	...	...	...	...	...	...
L. 915.0	5,415.00	3 5 0 0	17.000	35.00	4535.00	44 0 1 0 1 1 0 0 0	880
...	...	...	...	...	...	...	...
L. 919.9	5,419.98	3 9 9 8	17.996	39.98	4539.98	44 0 1 0 1 1 0 0 0	880
L. 920.0	5,420.00	2 0 0 0	14.000	20.00	4520.00	45 0 1 0 1 1 0 0 1	900
...	...	...	...	...	...	...	...
L. 950.0	5,450.00	3 0 0 0	16.000	30.00	4530.00	46 0 1 0 1 1 1 1 0	920
...	...	...	...	...	...	...	...
L. 999.0	5,499.98	3 9 9 8	17.996	39.98	4539.98	48 0 1 1 0 0 0 0 0	960
0.0	5,500.00	2 0 0 0	14.000	20.00	4520.00	49 0 1 1 0 0 0 0 1	980
...	...	...	...	...	...	...	...
10.0	5,510.00	3 0 0 0	16.000	30.00	4530.00	49 0 1 1 0 0 0 0 1	980
...	...	...	...	...	...	...	...
100.0	5,600.00	2 0 0 0	14.000	20.00	4520.00	54 0 1 1 0 1 1 1 0	1080
...	...	...	...	...	...	...	...
200.0	5,700.00	2 0 0 0	14.000	20.00	4520.00	59 0 1 1 1 0 0 1 1	1180
...	...	...	...	...	...	...	...
300.0	5,800.00	2 0 0 0	14.000	20.00	4520.00	64 1 0 0 0 0 0 0 0	1280
...	...	...	...	...	...	...	...
400.0	5,900.00	2 0 0 0	14.000	20.00	4520.00	69 1 0 0 0 1 0 0 1	1380
...	...	...	...	...	...	...	...
500.0	6,000.00	2 0 0 0	14.000	20.00	4520.00	74 1 0 0 1 0 1 0 0	1480
...	...	...	...	...	...	...	...
599.9	6,099.98	3 9 9 8	17.996	39.98	4539.98	78 1 0 0 1 1 1 1 0	1560

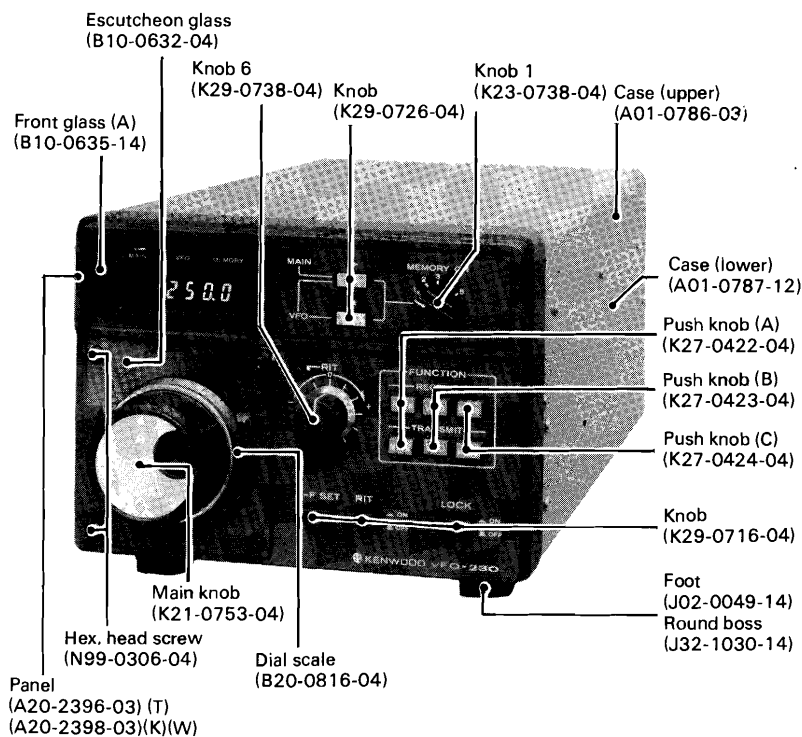
(Note) BAND: ○ ○ .0 MHz (ex. 14.0 MHz)

Table 13. Frequency chart

# VFO-230

## SPECIFICATIONS

Oscillation frequency ...	5.40 ~ 6.10 MHz	
Output voltage .....	0.2V $\pm 1$ dB	
Frequency stability .....	Within $\pm 1 \times 10^{-5}$ at 0 - 50°C within $\pm 3 \times 10^{-5}$ at room temp.	
Power consumption .....	13W	
Power requirement .....	AC 120V 50/60Hz (in U.S.A.) AC 220V/240V (Selectable) 50/60Hz (in Europe)	
Semiconductors used ...	CPU LSI .....	1
	FET .....	1
	IC .....	29
	Transistors .....	55
	Diodes .....	57
Dimensions .....	180 (182) W	7.09"
	133 (147) H	5.24"
	287 (330) D mm	11.30"
	(Figures in ( ) include projections.)	
Weight .....	Approx. 3 kg (6.61 Lbs.)	



## CIRCUIT CONFIGURATION

The VFO-230 consists of a double PLL loop: the 1st loop covering a 20 kHz bandwidth at 20 Hz step, and the 2nd loop covering a 700 kHz bandwidth at 20 kHz step.

As the tuning dial is turned, an optical encoder (using a photo sensor) converts the dial rotation and its direction of rotation into an electrical signal, which is coupled to microprocessor IC11 ( $\mu$ PD8048C-155)

The microprocessor internally processes this dial signal and outputs the processed result as frequency-division data for the PLL and, at the same time, provides the corresponding dial display data

In the 1st PLL loop, MIXER-1 (IC14  $\mu$ PC1037H) combines the output of VCO-1 (Q42, 43) at 14~17 998 MHz with a 10 MHz reference frequency to convert the output to 4.0~7 996 MHz. This output is amplified and coupled to Programmable Divider 1 (IC12), where it is frequency-divided according to the division data from the microprocessor into a 2 kHz signal

The phase of this 2 kHz signal is compared with that of the reference 2 kHz signal by phase comparator PD-1 (IC13), and this output is fed back to control the output frequency of VCO-1

The 4~7 998 MHz signal (at 4 kHz steps) generated in the 1st PLL loop is further frequency-divided by a 1/100 (IC15, 16) and 1/2 (IC6 1/2) divider into a 20~39.98 kHz signal (at a 20 Hz step) This signal is coupled to MIXER-2 (IC25), where it is mixed with a reference 500 kHz signal which converts the signal to 480~460.02 kHz. The output of the second mixer goes through a narrow-band ceramic filter (CF1), then couples to a third mixer, MIX-3 (IC27), where it is further mixed with a 5 MHz signal The signal is now converted to 4520~4539.98 kHz. A reference 5 MHz signal is usually used for the other input of this third mixer

However, it is supplied from the crystal oscillator (Q2) for RIT operation or CW transmission. When the RIT feature is ON, the voltage applied across the varicap diode in the crystal oscillator is varied by the RIT control to obtain a frequency variation range of  $\pm 900$  Hz. During CW transmission, the voltage across the varicap diode is adjusted by variable resistor VR1 on the digital unit to provide this oscillator with an output frequency 800 Hz higher than its original frequency The output of MIX-3 goes through a band-pass filter (T2, T3, T4), and then couples to a fourth mixer, MIX-4 (IC-26). Here it is mixed with the output of VCO-2 (5.4~6.09998 MHz) and is converted to 880~1560 kHz. This output, after amplification, is coupled to Programmable Divider 2 where it is frequency-divided to an output frequency of 20 kHz according to the division data supplied from the microprocessor. This output goes to phase detector PD-2 (IC24), where its phase is compared with the 20 kHz reference signal to create the frequency control signal for VCO-2

All the circuits hitherto described are always operating. However, the digital VFO provides its output intermittently to control the buffer amplifier. When the VFO in the main unit is operating, this VFO output is mixed with a 5 MHz reference signal by MIX-5 (Q5), of which output at 400 kHz to 1099.98 kHz is amplified, then counted up by a 6-digit frequency counter (IC8) The output data of this counter is stored into the microprocessor's memory.

As seen above, all frequencies except the RIT and CW transmission shift frequencies are composed of combinations of reference frequencies. As a result, the accuracy and stability of the digital VFO output frequency is identical to that of the 10 MHz reference oscillator.

# VFO-230

The frequency display resolution is identical to that of the main unit (down to 100 Hz) except for the RIT and CW transmission frequency display. This is accomplished by dynamically driving the fluorescent display tube based on the display and column data furnished by the microprocessor. The power to the VFO-230 is interlocked with that of the main unit. If, however, the VFO-230 is plugged into an AC outlet, the display, memory and output of the VFO remain live even when the power switch on the main unit is OFF. Therefore, when the main unit is again powered-on, the operating state set prior to power-off will reappear. Back-up power consumption for the VFO-230 is approximately 10 mA at 5V.

Item	Rating
Center frequency	470 kHz
6 dB bandwidth	± 12.5 kHz or more
50 dB bandwidth	± 25 kHz or less
Ripple (within 455±8 kHz)	3 dB or less
Loss	4 dB or less
Guaranteed attenuation	35 dB or less within 455±100 kHz
Input and output impedance	1.5 kΩ

Fig. 11 Ceramic filter (L71-0321-05) CFW470C (DIGITAL UNIT, CF 1)

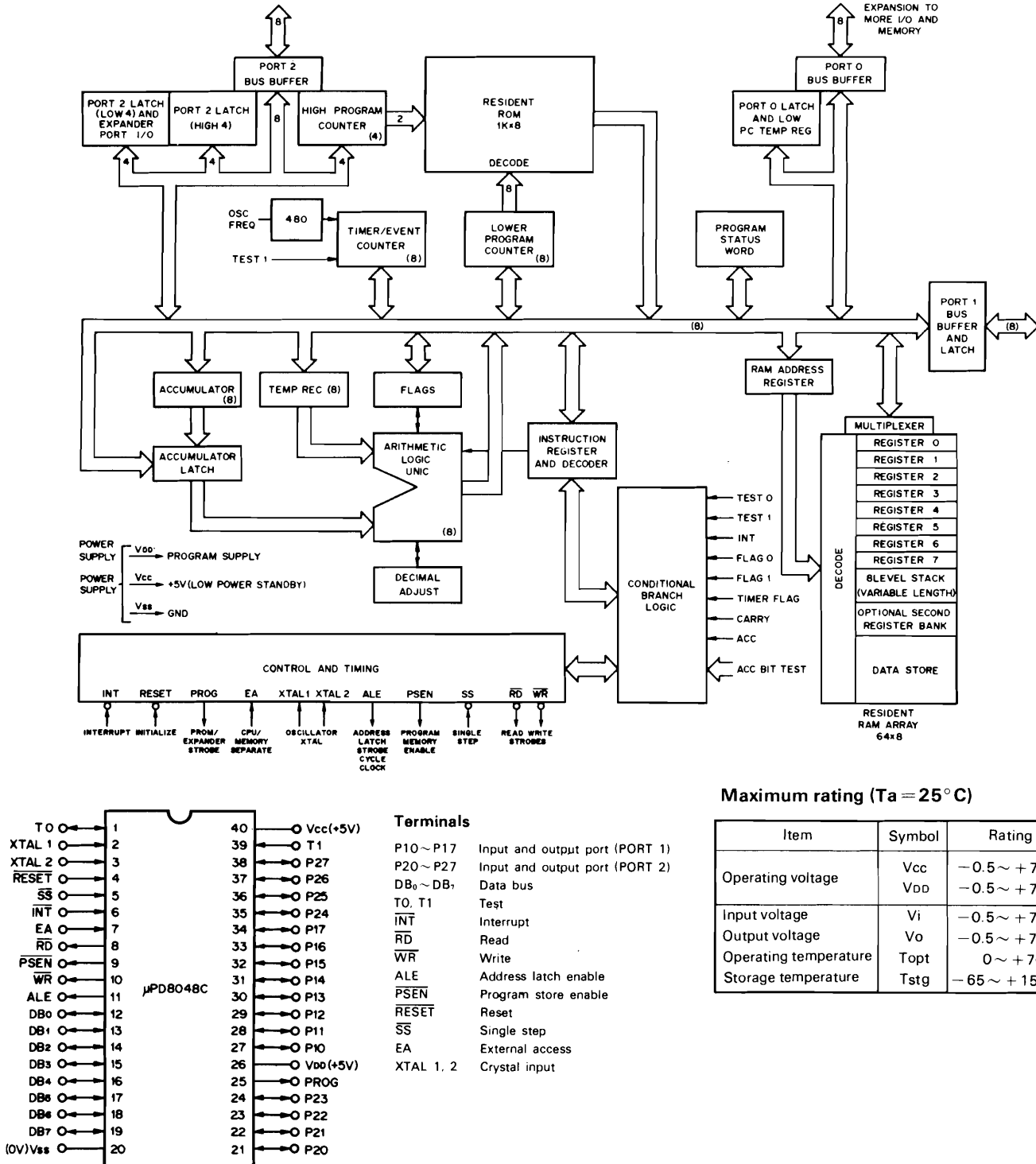
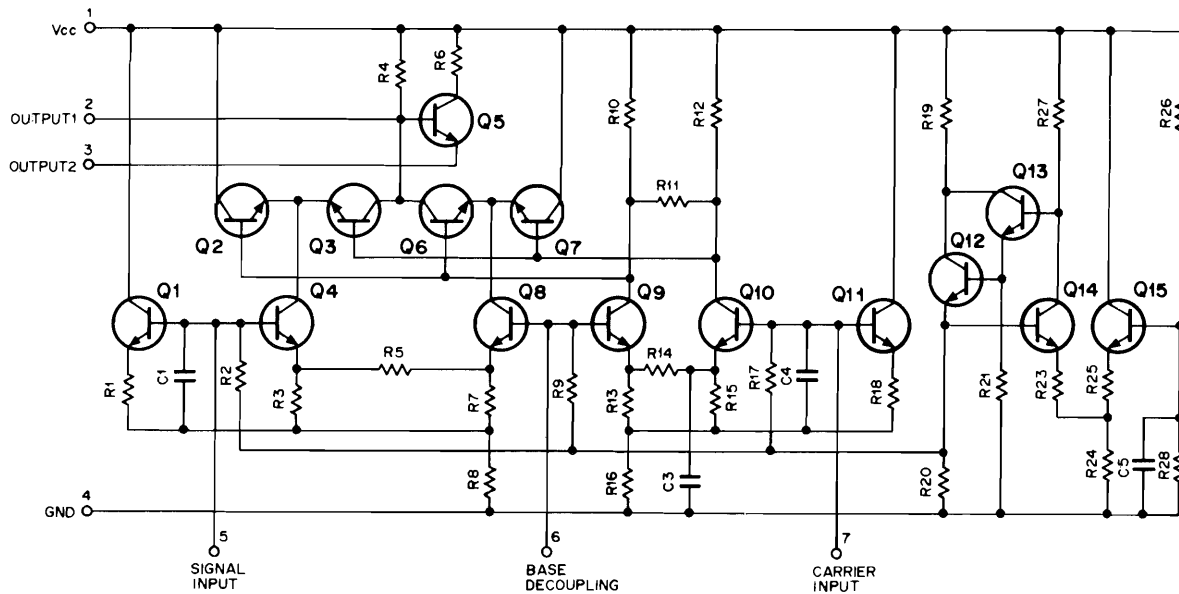


Fig. 13 μPD8048C-155 (DIGITAL UNIT, IC11)

## Maximum rating (Ta = 25°C)

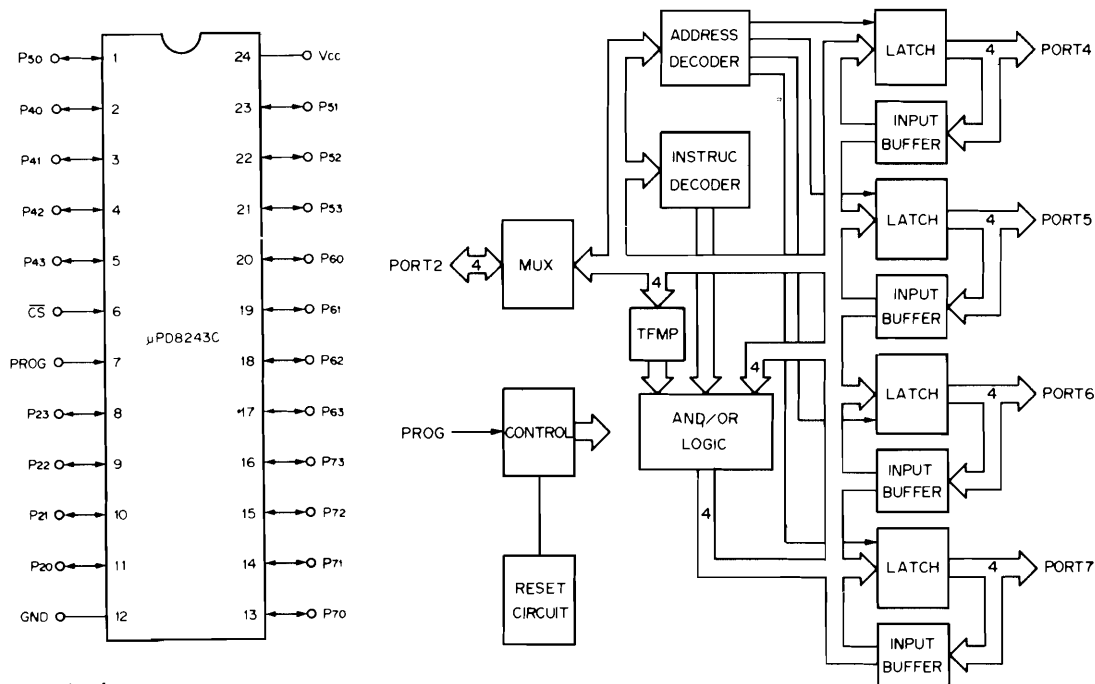
Item	Symbol	Rating
Operating voltage	V <sub>CC</sub>	-0.5 ~ +7.0V
	V <sub>DD</sub>	-0.5 ~ +7.0V
Input voltage	V <sub>i</sub>	-0.5 ~ +7.0V
Output voltage	V <sub>o</sub>	-0.5 ~ +7.0V
Operating temperature	T <sub>opt</sub>	0 ~ +70°C
Storage temperature	T <sub>stg</sub>	-65 ~ +150°C

# VFO-230



Item	Symbol	Rating
Operating voltage	Vcc	9.0V
Dissipation	Pd	270 mW (Ta = 75°C)
Operating temperature	Topt	-30 ~ +75°C
Storage temperature	Tstg	-40 ~ +125°C

Fig. 14  $\mu$ PC1037H Double Balanced Modulator (DIGITAL UNIT, IC14)



## Terminals

P <sub>20</sub> ~ P <sub>23</sub>	Input Output (Port 2)
P <sub>40</sub> ~ P <sub>43</sub>	Input Output port (Port 4)
P <sub>50</sub> ~ P <sub>53</sub>	Input Output port (Port 5)
P <sub>60</sub> ~ P <sub>63</sub>	Input Output port (Port 6)
P <sub>70</sub> ~ P <sub>73</sub>	Input Output port (Port 7)
$\overline{CS}$	Chip Select
PROG	Program pulse
	Input Output port (Port 2)

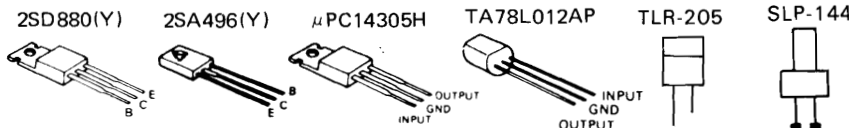
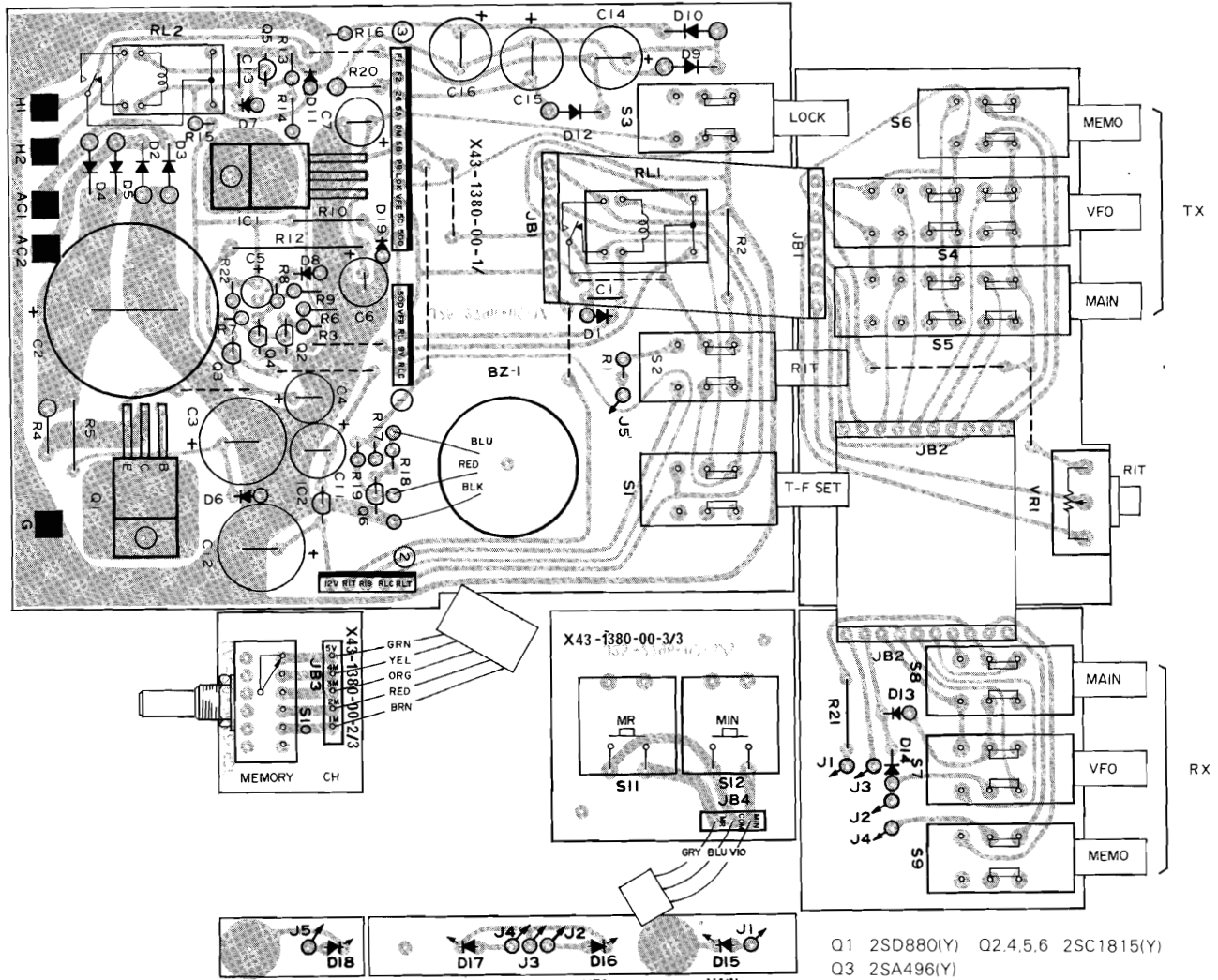
## Maximum Rating (Ta = 25°C)

Item	Symbol	Rating
Operating voltage	Vcc	-0.5 ~ +7V
Input voltage	Vi	-0.5 ~ +7V
Output voltage	Vo	-0.5 ~ +7V
Operating temperature	Topt	0 ~ +70°C
Storage temperature	Tstg	-60 ~ +150°C

Fig. 15  $\mu$ PD8243C (DIGITAL UNIT, IC10, 17)

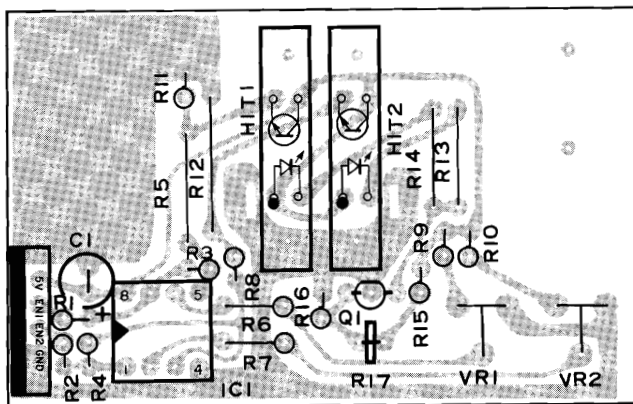
# VFO-230

## ▼ POWER SUPPLY UNIT (X43-1380-00)

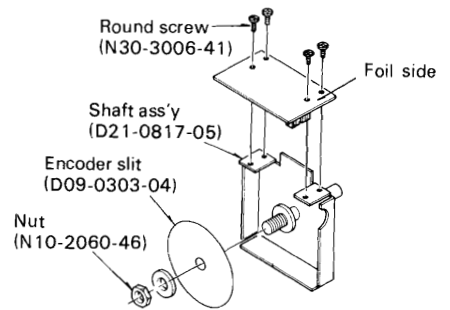


- Q1 2SD880(Y) Q2 4.5.6 2SC1815(Y)  
 Q3 2SA496(Y)  
 IC1 μPC14305H IC2 TA78L012AP  
 D1,7,8,13,14 1S1555 D2~5,9,10,12 V06B  
 D6 WZ-150 D19 XZ-049 D15~17 TLR-205  
 D18 SLP-144

## ▼ ENCODER UNIT (X54-1580-00)



- Q1 2SA1015(Y)  
 IC1 LM358P  
 HIT1,2 ON1105

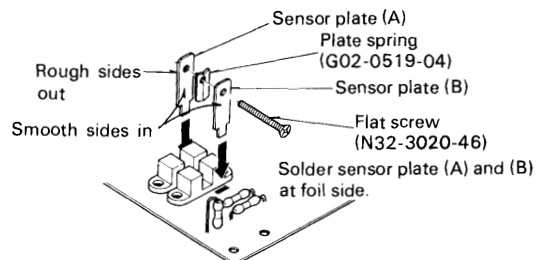
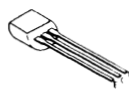


ON1105

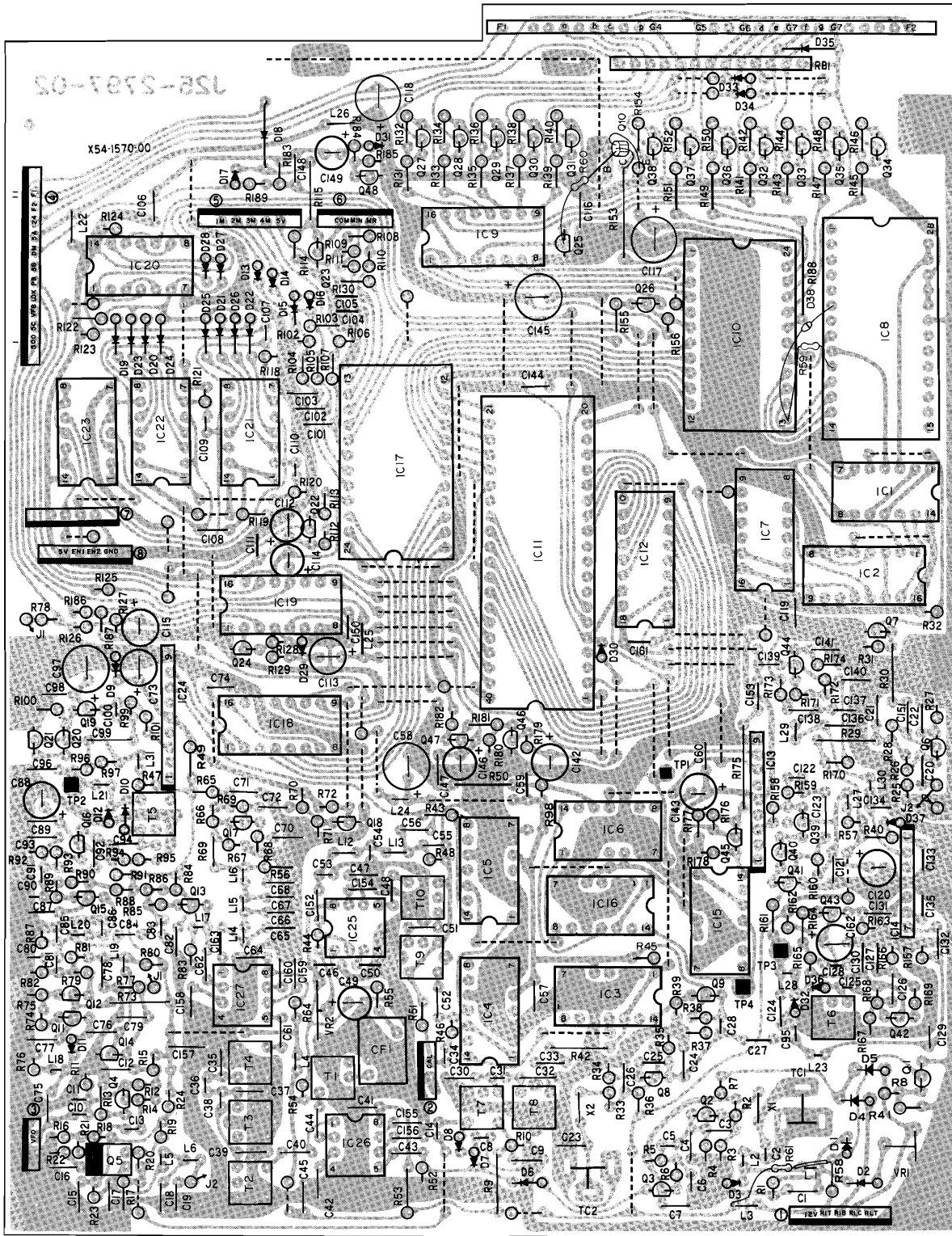
Max. Rating

VR	IF	PD	IC	V <sub>CEO</sub>	V <sub>ECO</sub>	PC	T <sub>OP</sub>
3V	50mA	75mW	20mA	30V	5V	100mW	-25 ~ +85°C

2SA1015 (Y)



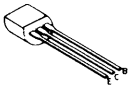
# VFO-230



▼ DIGITAL UNIT (X54-1570-00)

Q1~4.6~9.12.13.15~18.23~26.42~46. 2SC1815(Y) Q5 3SK73(GR) Q10.22.27~38.47.48: 2SA1015(Y) Q11.14 2SC1959(Y)  
 Q19~21.39~41 2SC1775(E)  
 IC1.20~23 TC4011BP IC2 TC4027BP IC3~6.15.16 SN74LS90N IC7 TC4518BP IC8. TC5032P IC9 SN74LS247N IC10.17  $\mu$ PD8243C  
 IC11  $\mu$ PD8048C 155 IC12 TC9122P IC13.24 TC5081P IC14  $\mu$ PC1037H IC18 MC14569B IC19 HD74LS151P IC25~27 SN16913P  
 D1.2.4.5.13~31.33~35.38 1S1555 D3.10.12.32.36 1SV54GC D6~8.11 1S1587 D9 WZ-050 D37 WZ-061

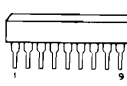
2SA1015(Y)  
 2SC1775(E)  
 2SC1815(Y)  
 2SC1959(Y)



3SK73(GR)



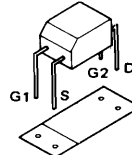
TC5081P



$\mu$ PC1037H



Attachment direction of  
 Q5 3SK73(GR)



# VFO-230

## VFO-230 Semiconductor

☆: New Parts

## VFO-230 General

Item	Name	Parts No.	Re- marks
Diode	1S1555	V11-0076-05	
	1S1587	V11-0370-05	
	V06B	V11-0219-05	
Vari-cap diode	1SV54GC	V11-4173-46	☆
Thermistor	25D29	V11-3360-16 500Ω at 25°C	
Zener diode	XZ-049	V11-4175-46	
	WZ-050	V11-4102-10	
	WZ-061	V11-0243-05	
	WZ-110	V11-4161-46	☆
	WZ-150	V11-0307-05	
LED	SLP-144	V11-6172-76	
	TLR-205	V11-3162-96	
Photo interruptor	ON 1105	V11-1173-76	☆
Display tube	9-BT-12	V40-7760-86	
TR	2SA496 (Y)	V01-0113-05	
	2SA1015 (Y)	V01-1015-06	
	2SC1775 (E)	V03-1775-06	
	2SC1815 (Y)	V03-1815-06	
	2SC1959 (Y)	V03-1959-06	
FET	2SD880 (Y)	V04-0880-16	
	3SK73 (GR)	V09-1002-46	
	IC	HD74LS151P	V30-1008-26
IC	LM358P	V30-1024-56	
	MC14569B	V30-1100-06	
	SN16913P	V30-1048-06	
	SN74LS90N	V30-1005-26	
	SN74LS247N	V30-1030-56	
	TA78L012AP	V30-1189-16	
	TC4011BP	V30-0301-70	
	TC4027BP	V30-1050-06	
	TC4518BP	V30-1039-06	
	TC5032P	V30-1091-06	
	TC5081P	V30-1132-06	
	TC9122P	V30-1036-16	
	μPC1037H	V30-1179-16	☆
	μPC14305H	V30-1029-36	
	μPD8048C-155	V30-1176-26	☆
μPD8243C	V30-1177-16	☆	

Ref. No.	Parts No.	Description	Re- marks
	A01-0786-03	Case (Upper)	☆
	A01-0787-12	Case (Lower)	☆
	A20-2398-03	Panel (K)(W)	☆
	A20-2396-03	Panel (T)	☆
	B09-0011-04	Cap	
	B10-0632-04	Escutcheon glass	
	B10-0635-14	Front glass (A)	☆
	B10-0636-04	Front glass (B)	☆
	B20-0816-04	Dial scale (B)	
	B46-0058-10	Warranty card (K)	
	B50-2753-00	Operating manual (K)(W)	☆
	B50-2754-00	Operating manual (T)	☆
	E06-0852-05	8P DIN socket	
	E14-0101-05	Pin plug	
	E13-0101-05	Pin jack	
	E30-0181-05	AC cord with plug (K)	
	E30-0585-05	AC cord with plug (W)	
	E30-0602-05	AC cord with plug (T)	
	E30-1632-05	Gnd cable	
	E30-1672-05	VFO cable	☆
	F05-3011-05	Fuse 0.3A (T)(W)	☆
	F05-5011-05	Fuse 0.5A (K)	
	G01-0804-04	Coil spring	
	G09-0410-05	D spring	
	H01-2711-04	Carton case (inside) (K)(W)	☆
	H01-2712-04	Carton case (inside)(T)	☆
	H10-2545-02	Packing fixture (F)	
	H10-2525-02	Packing fixture (R)	
	H20-0276-03	Protective cover	
	H25-0117-04	Accessories bag	
	J02-0049-14	Foot (large)	
	J13-0407-15	Fuse holder	
	J32-0714-04	Hex. boss	
	J32-1030-14	Round boss (foot)	
	J41-0006-05	Cord bush (K)	
	J41-0024-15	Cord bush (T)(W)	
	K21-0753-04	Main knob	
	K23-0738-04	Knob 1	
	K27-0422-04	Push knob (A), Main	☆
	K27-0423-04	Push knob (B), VFO	☆
	K27-0424-04	Push knob (C), Memo	☆
	K29-0716-04	Knob	
	K29-0726-04	Knob, Memo	
	K29-0738-04	Knob 6	
	L01-8044-05	Power trans	☆
L2. 4	L40-1011-04	Ferri-inductor 100μH	
L1. 3, 5	L40-1511-03	Ferri-inductor 150μH	
L5.6	L40-6891-13	Ferri-inductor 6.8μH	
	N09-0256-05	Gnd screw	
	N14-0115-05	Flange nut (Hex. bolt)	
	N14-0404-04	Flange nut (Pow trans)	
	N14-0509-05	Wing nut. GND	
	N14-0519-05	Fastener (Hex bolt)	☆

Ref No
N
N
S
X
X
X

### Power su

Ref No.
C2
C3
C4
C5
C6
C7
C11
C12
C14
C15
C16
R4
R12
R20
VR1
S1~3
S4~6
S7~9
S10
S11, 12
RL1, 2
BZ1

### Digital u

Ref. No.
C2
C4
C5, 6
C8
C10, 11
C14
C15, 16
C17
C18
C19
C23
C24
C25

# VFO-230

Ref No	Parts No.	Description	Re marks
	N19-0608-04	Washer (encoder)	
	N99-0306-04	Hex. head screw	
	S31-2027-05	Slide switch (T)(W)	
	X43-1380-00	Power supply unit	☆
	X54-1570-00	Digital unit	☆
	X54-1580-00	Encoder unit	☆

## Power supply unit (X43-1380-00)

Ref. No.	Parts No.	Description	Re- marks
C2	C90-0829-05	E 4700 $\mu$ F 35V	☆
C3	CE04W1C102M	E 1000 $\mu$ F 16V	
C4	CE04W1C101Q	E 100 $\mu$ F 16V	
C5	CE04W1C220M	E 22 $\mu$ F 16V	
C6	CE04W1E100M	E 10 $\mu$ F 25V	
C7	CE04W1A470M	E 47 $\mu$ F 10V	
C11	CE04W1C101Q	E 100 $\mu$ F 16V	
C12	CE04W1C102M	E 1000 $\mu$ F 16V	
C14	CE04W1E221M	E 220 $\mu$ F 25V	
C15	CE04W1C221M	E 220 $\mu$ F 16V	
C16	CE04W1E221M	E 220 $\mu$ F 25V	
	E23-0046-04	Square terminal	
R4	RS14AB3A4R7J	Metal film 4.7 $\Omega$ 1W	
R12	RS14GB3D270J	Metal film 27 $\Omega$ 2W	
R20	RS14AB3A221J	Metal film 220 $\Omega$ 1W	
	R92-0150-05	Short jumper	
VR1	R01-2406-05	Pot. 5k $\Omega$ (B)	☆
S1~3	S40-2420-05	Push switch (C) T-F set. RIT. LOCK	☆
S4~6	S42-3403-05	Push switch (B) TX-VFO, MAIN, MEMO	☆
S7~9	S42-3402-05	Push switch (A) RX-VFO, MAIN, MEMO	☆
S10	S01-2425-05	Rotary switch M. CH	☆
S11, 12	S50-1403-05	Tact switch MR, MIN	
RL1, 2	S51-1404-05	Relay	
BZ1	T95-0051-05	Transducer	

## Digital unit (X54-1570-00)

Ref. No.	Parts No.	Description	Re marks
C2	CC45UJ1H330J	C 33pF	
C4	CC45SL1H151J	C 150pF	
C5, 6	CC45SL1H100D	C 10pF $\pm 0.5$ pF	
C8	CC45SL1H220J	C 22pF	
C10, 11	CC45CH1H050C	C 5pF $\pm 0.25$ pF	
C14	CC45SL1H220J	C 22pF	
C15, 16	C91-0456-05	C 0.047 $\mu$ F	
C17	CC45SL1H101J	C 100pF	
C18	CC45SL1H221J	C 220pF	
C19	CC45SL1H101J	C 100pF	
C23	CC45SL1H390J	C 39pF	
C24	CC45SL1H470J	C 47pF	
C25	CC45SL1H331J	C 330pF	

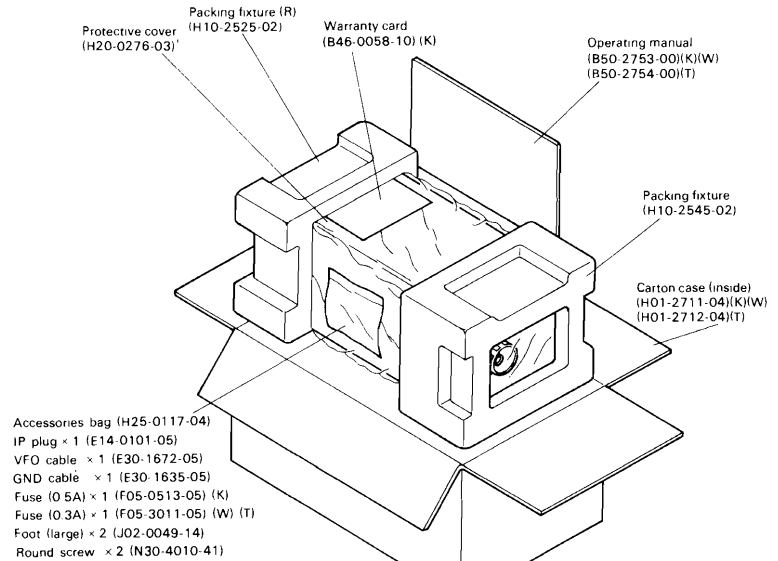
Ref. No.	Parts No.	Description	re- marks
C27	CC45CH1H070D	C 7pF $\pm 0.5$ pF	
C28	CC45SL1H150J	C 15pF	
C30	CC45RH1H820J	C 82pF	
C31	CC45RH1H020C	C 2pF $\pm 0.25$ pF	
C32	CC45RH1H820J	C 82pF	
C33	CC45SL1H221J	C 220pF	
C34	CC45CH1H010C	C 1pF $\pm 0.25$ pF	
C35	CC45RH1H101J	C 100pF	
C36	CC45RH1H020C	C 2pF $\pm 0.25$ pF	
C37	CC45RH1H101J	C 100pF	
C38	CC45RH1H020C	C 2pF $\pm 0.25$ pF	
C39	CC45RH1H101J	C 100pF	
C49	CE04W1C470M	E 47 $\mu$ F 16V	
C51	CC45RH1H050C	C 5pF $\pm 0.25$ pF	
C52	CC45SL1H101J	C 100pF	
C53	CQ92M1H562K	ML 0.0056 $\mu$ F 50V	
C54	CQ92M1H123K	ML 0.012 $\mu$ F 50V	
C55	CQ92M1H562K	ML 0.0056 $\mu$ F 50V	
C56	CQ92M1H473K	ML 0.047 $\mu$ F 50V	
C57	C91-0456-05	C 0.047 $\mu$ F	
C58	CE04W1A221M	E 220 $\mu$ F 10V	
C59, 60	C91-0456-05	C 0.047 $\mu$ F	
C65	CC45SL1H151J	C 150pF	
C66, 67	CC45SL1H271J	C 270pF	
C68	CC45SL1H151J	C 150pF	
C69	CC45SL1H101J	C 100pF	
C72	CC45SL1H101J	C 100pF	
C73	CE04W1A101M	E 100 $\mu$ F 10V	
C74	C91-0456-05	C 0.047 $\mu$ F	
C80	CC45SL1H150J	C 15pF	
C81	CC45SL1H100D	C 10pF $\pm 0.5$ pF	
C83	CC45SL1H220J	C 22pF	
C84	CC45CH1H070D	C 7pF $\pm 0.5$ pF	
C85, 86	CC45SL1H330J	C 33pF	
C88	CE04W1E100Q	E 10 $\mu$ F 25V	
C90	CC45RH1H050C	C 5pF $\pm 0.25$ pF	
C91	CC45RH1H120J	C 12pF	
C93	CC45RH1H470J	C 47pF	
C94	CC45RH1H390J	C 39pF	
C95	CC45SL1H330J	C 33pF	
C97	CE04W1C101Q	E 100 $\mu$ F 16V	
C98	C91-0456-05	C 0.047 $\mu$ F	
C99	CQ92M1H104K	ML 0.1 $\mu$ F 50V	
C100	CQ92M1H102K	ML 1000pF 50V	
C106	C91-0456-05	C 0.047 $\mu$ F	
C111	C91-0456-05	C 0.047 $\mu$ F	
C112, 113	CE04W1A470Q	E 47 $\mu$ F 10V	
C114, 115	CE04W1H010M	E 1 $\mu$ F 50V	
C116	C91-0456-05	C 0.047 $\mu$ F	
C117	CE04W1A101M	E 100 $\mu$ F 10V	
C118	CE04W1E470Q	E 47 $\mu$ F 25V	
C119	C91-0456-05	C 0.047 $\mu$ F	
C120	CE04W1C101Q	E 100 $\mu$ F 16V	
C121	C91-0456-05	C 0.047 $\mu$ F	
C123	CQ92M1H104K	ML 0.1 $\mu$ F 50V	
C125	CC45RH1H120J	C 12pF	
C126	CC45RH1H470J	C 47pF	
C127	CC45RH1H680J	C 68pF	
C128	CC45RH1H050C	C 5pF $\pm 0.25$ pF	
C129	CC45SL1H330J	C 33pF	
C134	CC45SL1H470J	C 47pF	
C136	CC45SL1H101J	C 100pF	



Ref. No.	Parts No.	Description	Re- marks
C137	CC45SL1H470J	C 47pF	
C142	CE04W1H2R2M	E 2.2μF 50V	
C143	CE04W1A101M	E 100μF 10V	
C144	C91-0456-05	C 0.047μF	
C145	CE04W1A221M	E 220μF 10V	
C146	CE04W1A470Q	E 47μF 10V	
C147	C91-0456-05	C 0.047μF	
C149	CE04W1H4R7Q	E 4.7μF 50V	
C152	CQ92M1H473K	ML 0.047μF 50V	
C153	CC45SL1H150J	C 15pF	
C161	C91-0456-05	C 0.0047μF	
C162	CE04W1C470M	E 47μF 16V	
	E23-0046-04	Square terminal	
	G13-0635-04	Cushion	☆
TC1	C05-0048-05	Ceramic trimmer 70pF	
TC2	C05-0035-05	Ceramic trimmer 50pF	
L1	L40-1021-03	Ferri-inductor 1mH	
L2	L40-4701-03	Ferri-inductor 47μH	
L3	L40-1511-03	Ferri-inductor 150μH	
L4	L40-4711-03	Ferri-inductor 470μH	
L5, 6	L40-2211-03	Ferri-inductor 220μH	
L7~11	Not Used		
L12-13	L40-3325-04	Ferri-inductor 3.3mH	
L14~16	L40-1011-03	Ferri-inductor 100μH	
L17~19	L40-4711-03	Ferri-inductor 470μH	
L20	L40-1501-03	Ferri-inductor 15μH	
L21	L40-4711-03	Ferri-inductor 470μH	
L22	L40-1511-04	Ferri-inductor 150μH	
L23	L40-1501-03	Ferri-inductor 15μH	
L24, 25	L40-1511-03	Ferri-inductor 150μH	
L26	L40-1511-04	Ferri-inductor 150μH	
L27	L40-1021-03	Ferri-inductor 1mH	
L28	L40-1511-03	Ferri-inductor 150μH	
L29, 30	L40-1001-03	Ferri-inductor 10μH	
L31	L40-1021-03	Ferri-inductor 1mH	
T1	L34-0991-05	Tuning coil 470kHz	☆
T2~4	L34-0996-15	Tuning Coil 4.5 MHz	☆
T5	L32-0636-05	Oscillating Coil	☆
T6	L32-0193-05	Oscillating coil	
T7, 8	L34-0996-15	Tuning coil 4.5MHz	☆
T9, 10	L34-0991-05	Tuning coil 470kHz	☆
CF1	L72-0321-05	Ceramic filter CFW470C	☆
X1	L77-0874-05	Crystal 5MHz	☆
X2	L77-0482-05	Crystal 10MHz	☆
VR1	R12-3045-05	Trim. pot 10kΩ (B)	
VR2	R12-5014-05	Trim. pot 100kΩ (B)	
RB1	R90-0523-05	Rosistor block 47kΩ × 12	
	R92-0150-05	Short jumper	

Ref. No.	Parts No.	Description	re- marks
C1	CE04W1A470Q	E 47μF 10V	
	D09-0303-04	Encoder slit	☆
	D21-0817-05	Shaft ass'y	☆
	G02-0519-04	Plate spring	☆
VR1, 2	R12-1040-05	Trim pot 4.7 kΩ (B)	

### PACKING



### ADJUSTMENTS

### TEST EQUIPMENT REQUIRED

#### 1. VTVM or DVM

- 1) Input resistance More than 1 MΩ
- 2) Voltage range 15 to 1000V AC/DC

#### NOTE:

A high-precision voltmeter may be used. However, accurate readings can not be obtained for high-impedance circuits.

#### 2. RF VTVM

- 1) Input impedance 1 MΩ and less than 3 pF
- 2) Voltage range 10 mV to 300V
- 3) Frequency range 50 MHz or greater

#### 3. OSCILLOSCOPE

Requires high sensitivity and external synchronization capability

#### 4. STANDARD SIGNAL GENERATOR (SSG)

- 1) Frequency range 1.8 to 30 MHz
  - 2) Output -20dB/0.1 μV ~ 120 dB/1V
  - 3) Output Z = 50Ω
- Generator must be frequency stable

#### 5. FREQUENCY COUNTER

- 1) Minimum input voltage 50 mV
- 2) Frequency range Greater than 50 MHz

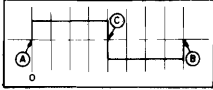
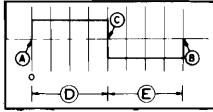
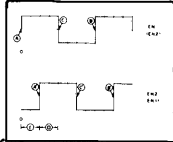
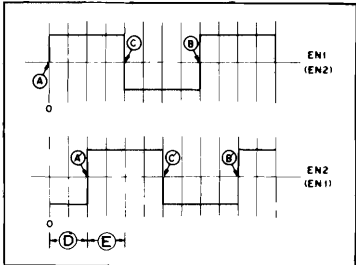
# VFO-230

## ADJUSTMENTS

Item	Condition	Measurement			Adjustment			Specification	Remarks
		Test equipment	Unit	Terminal	Unit	Parts	Method		
Setting	VFO-230: Front panel • MEMORY CH 1 • FUNCTION RECEIVE : VFO TRANSMIT : VFO • RIT : Centered • RIT SW : OFF • LOCK SW : OFF • T.F SET : OFF TS-830S • BAND : 14 • MODE : CW • POWER : ON • SG SW rear panel : OFF • CAL SW : OFF								
Use an insulated tuning tool for adjusting trimmer capacitors, coil slugs, etc.									

Item	Condition	Measurement			Adjustment			Specification	Remarks	
		Test equipment	Unit	Terminal	Unit	Parts	Method			
1 Reference oscillator adjustment		F.counter	Digital	TP1	Digital	TC2		5.000MHz ± 5 Hz		
	[Calibration using the TS-830S] Interconnect the TS-830S ANT terminal and the VFO-230 CAL terminal. Set the FUNCTION (REC) switch on the VFO-230 to MAIN. With the TS-830, receive a beat frequency at around 14.000, then set the CAL switch to ON (a double beat will be obtained.).							Obtain a zero beat between the double beats.		
	VFO-230: Set the FUNCTION (REC) switch to VFO. Turn the dial to check the following frequencies: L900.0, 0.0, 100.0, 200.0, 300.0, 400.0, 500.0							Check the frequency departure from the display on the TS-830.	Within ± 100 Hz.	Check
2. PLL-1 adjustment	Turn the control until 19.9 is obtained on the display.	F.counter	Digital	TP4				798 kHz	Check	
	Turn the control to scan the displayed frequency from 0.0 to 19.9.	DVM	Digital	TP3	Digital	T6	Set to 9.5V			
3. PLL-2 adjustment	Set the dial to display a frequency of 10.0.	RF VTVM	Digital	IC26 ②	Digital	T9 T10	Maximum (There should be a peak.)			
				IC26 ①		T1 T7 T8	Maximum (Broad at T1)			
				Q17 ③		T2 T3 T4	Maximum			
	Set the dial to a frequency display of 599.9.	DVM	Digital	TP2		T5	Set to 9.5V			
								2.0 ~ 9.5V ± 0.5V	Check	
	Turn the dial to scan displayed frequency from L900.0 to 599.9.	F.counter	Rear panel	DIN connector ①					5.4 ~ 6.1 MHz	
RF VTVM		Digital	Q17 ③	Digital	T4	Reset to maximum				

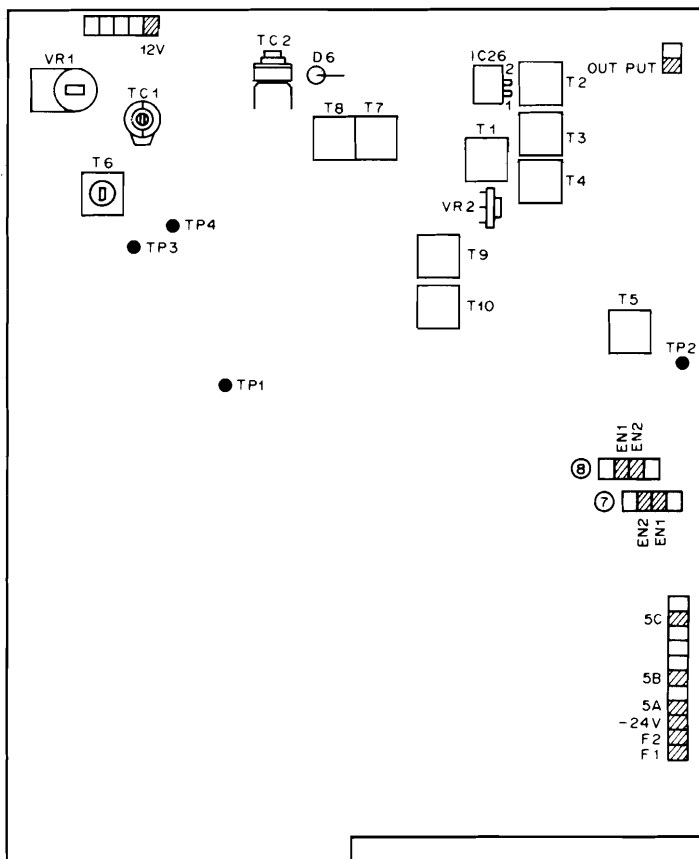
# VFO-230

Item	Condition	Measurement			Adjustment			Specification	Remarks
		Test equipment	Unit	Terminal	Unit	Parts	Method		
4. RIT adjustment	RIT control: Centered DISPLAY: 500.0	F.counter	Digital	Cathode of D6	Digital	TC1	Adjust so that the frequency counter reading does not change at RIT SW ON/OFF		
	RIT SW : ON RIT Control: Fully clockwise						Bracketed values are the TS-830S display indication.	More than 5,000.9 kHz (More than 14,500.9)	Check
	RIT SW : ON RIT Control: Fully counterclockwise							Less than 4,999.1 kHz (Less than 14,499.1)	
	RIT SW : OFF							5,000.0 kHz (14,500.0)	
5. CW SHIFT adjustment	TS-830 MODE : TUN VFO-230 RIT : OFF FUNCTION (REC) : VFO	F.counter	Digital	Cathode of D6	Digital	VR1	TS-830 MODE: Adjust until a frequency 800 Hz higher than the CW frequency is obtained.	800Hz ± 50 Hz	
	TS-830 MODE : CW.N STBY SW : SEND VFO-230 RIT : OFF FUNCTION (TRA) : VFO						TS-830 STBY: The frequency is shifted by 800 Hz with respect to REC freq.		
	TS-830 STBY SW REC								
6. Encoder adjustment	Remove the VFO knob and motor-drive the encoder at approx 300 rpm.	Oscilloscope	Digital	EN 1 terminal of Connectors ⑦ or ⑧					Point ③ may be located anywhere. When a motor is not available, manually turn the VFO control to check the duty ratio.
	EN 1 duty ratio adjustment: Turn a motor clockwise and counterclockwise.				Encoder	VR1			After adjusting with the VFO control turned clockwise, check that intervals ④ and ⑤ are also identical when the VFO control is turned counterclockwise.
	EN 2 duty ratio adjustment: Turn a motor in the both direction.			EN2 terminal of Connectors ⑦ or ⑧		VR2	Adjust until intervals ④ and ⑤ are equal to each other with point ③ placed at the center		
	EN1-EN2 phase difference alignment: Same as above.			EN1 and EN2 terminals of Connectors ⑦ or ⑧		Phase adjustment screw		EN1 (EN2): Within 90 deg ± 10%. (The difference between clockwise and counterclockwise rotation must also be within this specification.)	The phases of EN 1 and EN 2 may be replaced with each other as indicated in the brackets.
								Adjust until intervals ④ and ⑤ are equal to each other (point A' on EN2 is located in the middle of points A and C on EN1.)	

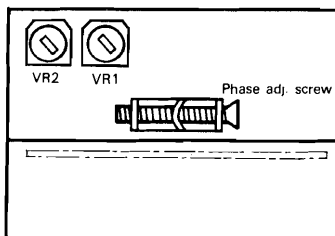
# VFO-230 PARTS LAYOUT/AC VOLTAGE CONVERSION

Item	Condition	Measurement			Adjustment		Specification	Remarks
		Test equipment	Unit	Terminal	Unit	Parts		
7 Beat adjustment	TS-830 AGC FAST RIT OFF RF ATT OFF VBT NORM IF SHIFT Centered MODE USB						Adjust the SSG output frequency until a maximum S-meter reading is obtained on the TS-830S	
	VFO-230 FUNCTION (REC) VFO DISPLAY (Dial) 20.0 Connect the SSG output to the ANT terminal on the TS-830S							
	Adjust the SSG attenuator until the S meter on the TS-830S indicates 20 dB.							
	Set the VFO-230's dial to 20.8 (zero beat)	Obtain a beat from the TS-830		Digital	VR2	Adjust to the minimum beat level.		
Turn the dial on the VFO-230 from 0.0 to around 50.0 while listening to the signals							An abnormal beat should not be heard	Check

## ▼ DIGITAL UNIT (X54-1570-00)



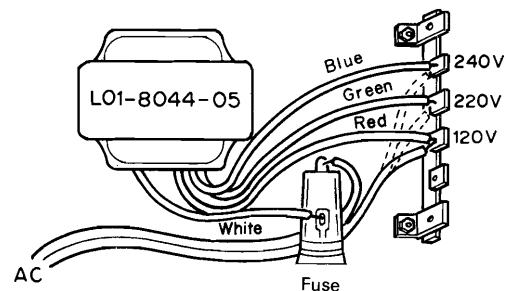
## ▼ ENCODER UNIT (X54-1580-00)

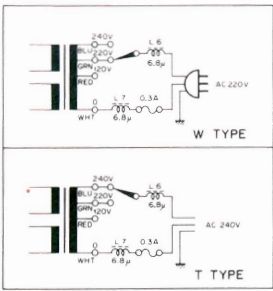


## VFO-230 (K) AC Voltage conversion

To operate the VFO-230 (K) on 240V AC, the power transformer primary tap must be rewired from 120V to either the 220V or 240V tap.

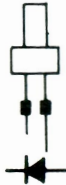
- 1 Unplug the AC power cable and VFO interconnecting cable.
- 2 Remove the top cover
- 3 Move the AC line from the 120V (Red) to either the 220V (Green) or 240V (Blue) transformer winding.
- 4 Change the AC fuse from 0.5A to 0.3A. Tag the power cord at the back of the unit to indicate that the transformer is wired for 240V AC, and the power fuse should be 0.3A and not 0.5A.
- 5 Replace the top cover and cable up to verify your work.





- Q1 : 2SD880(Y)    D1,7,8,13,14 : 1S1555    D15~17 : TLR-205  
 Q2,4~6 : 2SC1815(Y)    D2~5,9,10,12 : V06B    D18 : SLP-144  
 Q3 : 2SA496(Y)    D6 : WZ-150    D19 : XZ-049
- IC1 : µPC14305H  
 IC2 : TA78L012AP

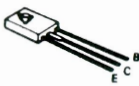
SLP-144



TLR-205



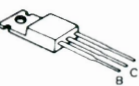
2SA496(Y)



2SA1015(Y)  
 2SC1775(E)  
 2SC1815(Y)  
 2SC1959(Y)



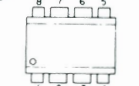
2SD880(Y)



3SK73(GR)



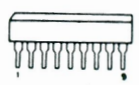
LM358P  
 SN16913P



TA78L012AP



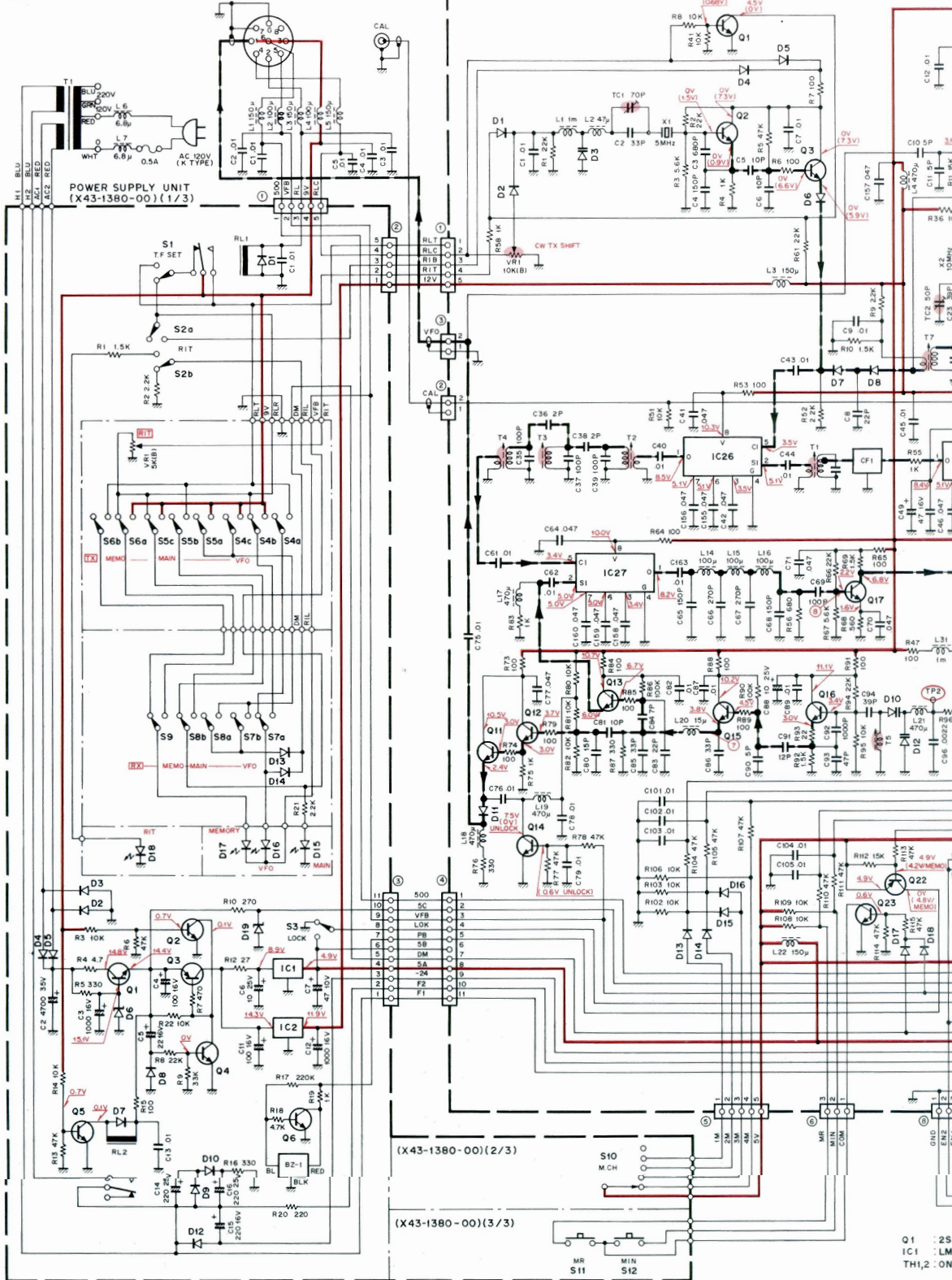
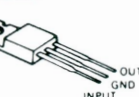
TC5081P



µPC1037H

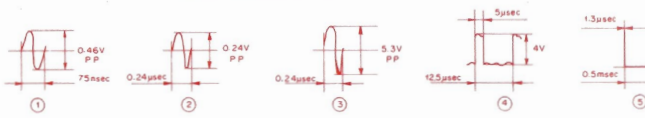


µPC14305H

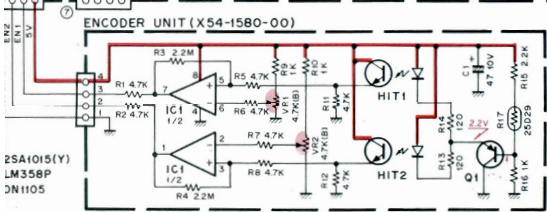
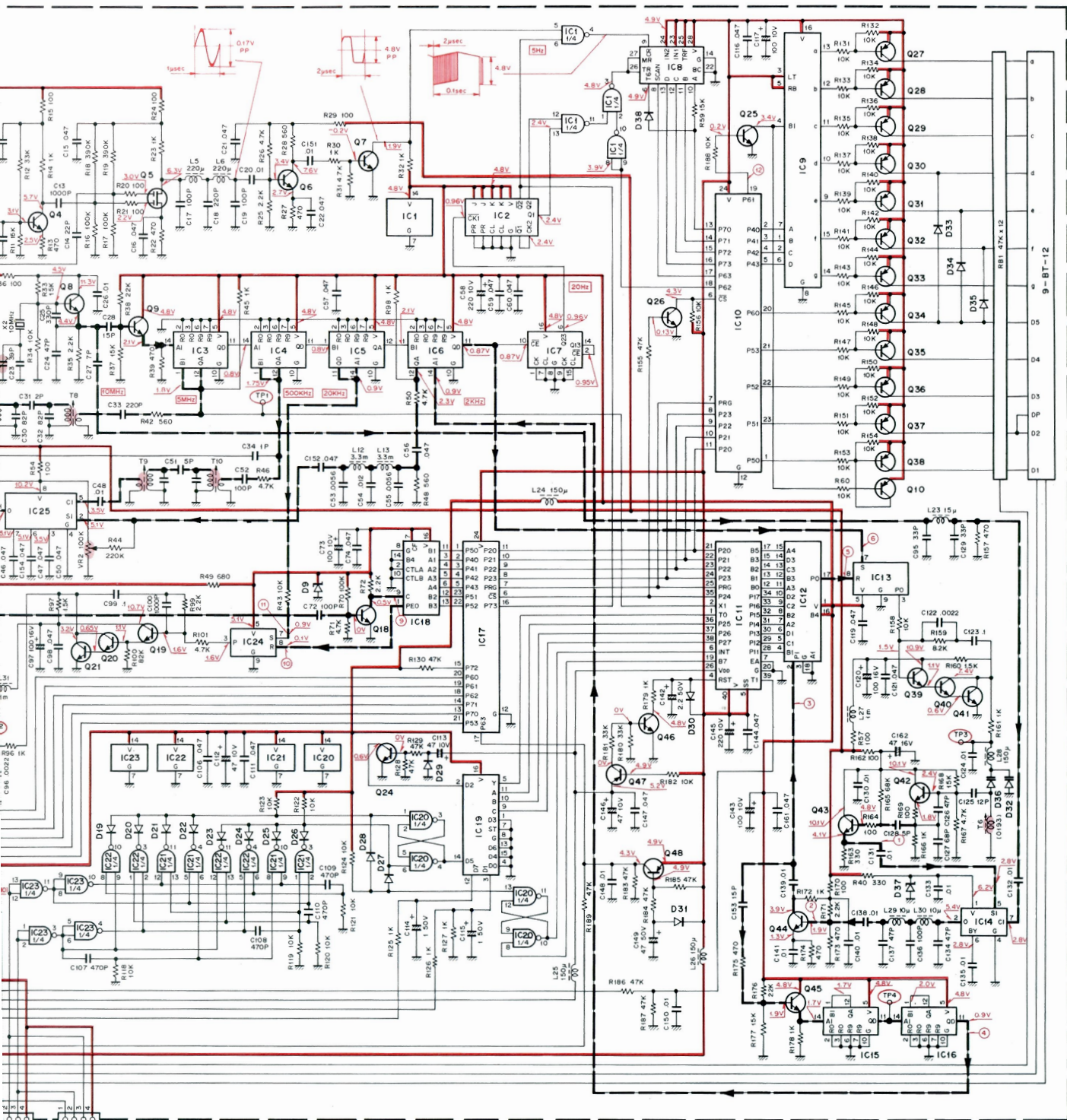


(X43-1380-00) (2/3)

(X43-1380-00) (3/3)

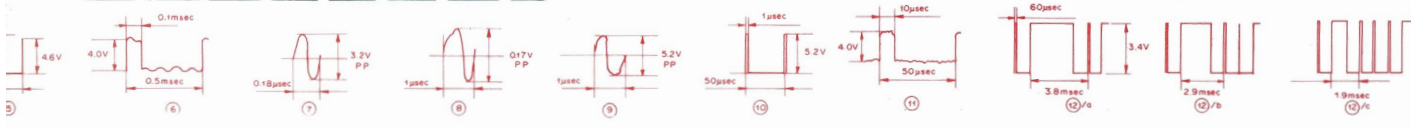






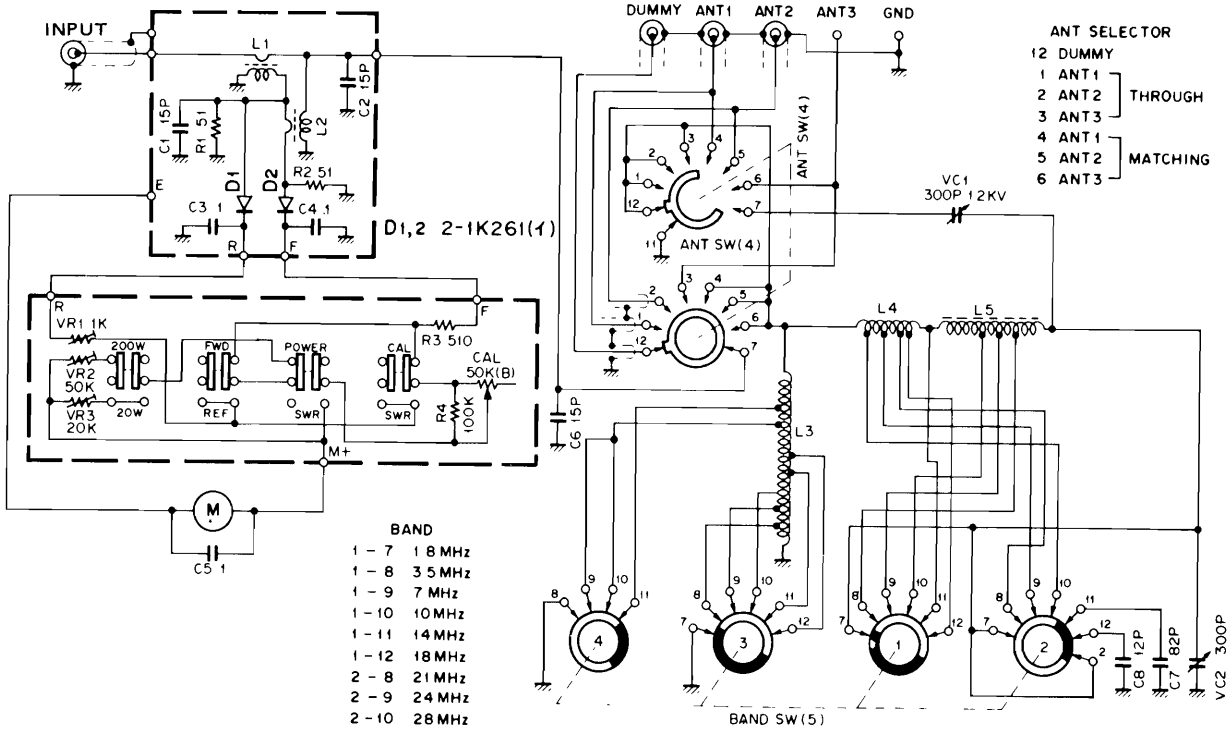
- Q 1~4, 6~9, 12, 13, 15~18, 23~26, 42~46
- Q 5
- Q 11, 14
- Q 19~21, 39~41
- Q 10, 22, 27~38, 47, 48: 2SA1015(Y)
- IC 1, 20~23
- IC 2
- IC 3~6, 15, 16
- IC 7
- IC 8
- IC 9
- IC 10, 17
- IC 11
- IC 12
- IC 13, 24
- IC 14
- IC 18
- IC 19
- IC 25~27
- D 1, 2, 4, 5, 13~31, 33~35, 38
- D 3, 10, 12, 32, 36
- D 6~8, 11
- D 9
- D 37
- IC 1: TC4011BP
- IC 2: TC4027BP
- IC 3: SN74LS90N
- IC 7: TC4518BP
- IC 8: TC5032P
- IC 9: SN74LS247N
- IC 10, 17:  $\mu$ PD8243C
- IC 11:  $\mu$ PD8048C-155
- IC 12: TC9122P
- IC 13, 24: TC5081P
- IC 14:  $\mu$ PC1037H
- IC 18: MC14569B
- IC 19: HD74LS151P
- IC 25~27: SN16913P
- D 1, 2, 4, 5, 13~31, 33~35, 38: 1S1555
- D 3, 10, 12, 32, 36: 1SV54BC
- D 6~8, 11: 1S1587
- D 9: WZ-U50
- D 37: WZ-O61

Display



< Note > Wave forms are displayed at 0.0 (VFO output 5.5 MHz).

# AT-230



## SPECIFICATIONS

### ANTENNA COUPLER

**Frequency Range** ... 9 amateur bands from 1.8 to 29.7 MHz  
**Input Impedance** ... 50Ω  
**Output Impedance** ... 10 to 500Ω, unbalanced  
**Through Power** ... 200W at max.  
**Insertion Loss** ... Less than 0.5 dB in matched state

**Pi-L** ... 1.8 MHz only  
**Output Impedance** ... 20 to 500Ω, unbalanced  
**Through Power** ... 100W at max.

### WATTMETER

**Type** ... Through-line wattmeter  
**Frequency Range** ... 1.8 to 30 MHz  
**Measurable RF Power** ... Up to 20/200W, switched Forward or reflected power switched

**Net weight** ... 3.4 kg (7.5 lbs.) approx.

**Impedance** ... 50Ω  
**Accuracy** ... Better than ±10% of full scale

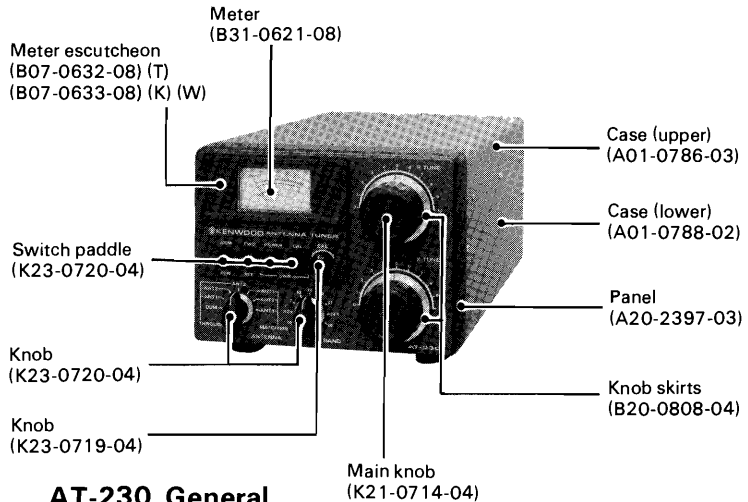
### SWR METER

**SWR Detection** ... Toroid core direction coupler  
**Measurable Range** ... 1:1 to 10  
**Min. Power Required** ... 4W

### GENERAL

#### Connectors

**INPUT** ... UHF type, 50Ω  
**ANT-1** ... UHF type  
**ANT-2** ... UHF type  
**ANT-3** ... Stud and wing nut  
**Dimensions** ...  
 W 180 mm (7-3/32")  
 H 133 mm (5-15/64")  
 D 288 mm (11-11/32")



### AT-230 General

Ref. No.	Parts No.	Description	Re- marks
	A01-0786-03	Case (upper)	☆
	A01-0788-02	Case (lower)	☆
	A20-2397-02	Panel	☆
	B07-0632-08	Meter escutcheon (T)	☆
	B07-0633-08	Meter escutcheon (K)(W)	☆
	B20-0808-04	Knob skirt	
	B31-0621-08	Meter	
	B46-0058-00	Warranty card (K)	
	B50-2756-08	Operating manual (K)(W)	☆
	B50-2757-08	Operating manual (T)	☆
VC1, 2	C02-0016-08	Variable cap 300pF 1.2kV	
C7	C91-0419-05	C 82pF 3kV	☆
C8	C91-0402-05	C 12pF 3kV	☆
	D23-0061-04	Bearing	

Ref. No.  
 L3  
 L4  
 L5  
 Switch  
 Ref. No.  
 VR1  
 VR2  
 VR3  
 VR4  
 R3  
 R4  
 Detect  
 Ref. No.  
 C1, 2  
 C6  
 R1, 2  
 D1, 2  
 L1, 2

# AT-230

Ref. No.	Parts No.	Description	Re- marks
	E04-0102-05	UHF type receptacle	
	E23-0015-04	Gnd lug $\phi 3$	
	E23-0408-05	Terminal	
	F09-0402-05	Insulating cover	
	F29-0402-08	Insulator	
	G13-0621-04	Cushion	
	H01-2714-04	Carton case (inside)(K)(W)	☆
	H01-2715-04	Carton case (inside)(T)	☆
	H10-2525-02	Packing fixture (R)	☆
	H10-2545-02	Packing fixture (F)	☆
	J02-0049-14	Foot (large)	
	J32-1030-04	Round boss	
	K21-0715-04	Main knob R, X Tune	
	K21-0745-08	Knob, BAND, ANT	
	K23-0719-04	Knob, CAL	
	K23-0720-04	Switch paddle	
L3	L34-0992-08	Coil	☆
L4	L34-0993-08	Coil	☆
L5	L34-0994-08	Coil	☆
	N14-0506-08	Wing nut, M5 ANT3, GND	
	S01-2418-08	Rotary switch, ANT	
	S01-5404-08	Rotary switch, BAND	☆
	W02-0302-08	Switch module	
	W02-0303-08	Detector module	

## Switch module (W02-0302-08)

Ref. No.	Parts No.	Description	Re- marks
VR1	R12-1024-05	Trim. pot 1k $\Omega$ (B)	
VR2	R12-4020-05	Trim. pot 50k $\Omega$ (B)	
VR3	R12-3420-08	Trim. pot 20k $\Omega$ (B)	
VR4	R05-3407-08	Pot. 50k $\Omega$ (B) CAL	
R3	RD14BB2E511J	Carbon resistor 510 $\Omega$ $\pm 5\%$ 1/4W	
R4	RD14BB2E104J	Carbon resistor 100k $\Omega$ $\pm 5\%$ 1/4W	
	S36-2026-15	Paddle switch $\times 4$	

## Detector module (W02-0303-08)

Ref. No.	Parts No.	Description	Re- marks
C1, 2	FM05ZC150J5	Mica 15pF 500V	
C6	FM05ZC150J5	Mica 15pF 500V	
R1, 2	RD14BB2E510J	Carbon resistor 51 $\Omega$ $\pm 5\%$ 1/4W	
D1, 2	V11-7763-26	Diode 2-1K261 $\times 2$	
L1, 2	L39-0403-08	Detector coil	

## 1. INSTRUMENTS

### 1) Terminated Power Meter

- Frequency range 50 MHz or more
- Input impedance 50 $\Omega$
- Power range 20W and 200W

### 2) HF Transmitter or Transceiver

- Output 100W CW  
Variable to 10W  
Example TS-830, TS-820S

## 2. POWER METER ADJUSTMENT

### 1) Test Equipment Connection

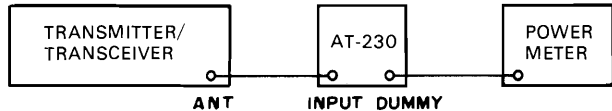


Fig. 1

### 2) Adjustment

- Connect as in Fig. 1
- Unless otherwise specified, controls should be set as follows

ANT SW	DUMMY
BAND SW	14
200W/20W SW	200W
FWD/REF SW	FWD
POWER/SWR SW	POWER
CAL/SWR SW	SWR

Tune up the transceiver at 14 175 MHz.

- Adjust the transceiver for 100W output at the power meter (adjusted by the carrier level control)  
Adjust VR2 on the switch unit for a meter reading of 100 on the AT-230.

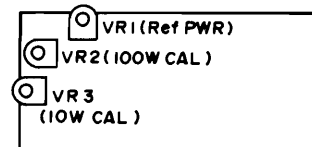


Fig. 2

- As in step 3, lower transceiver output to 10W and adjust VR3 for a meter indication of 10 on the 20W scale.

## 3. CALIBRATION OF REF POWER

### 1) Connection

As in Fig. 1

### 2) Adjustment

- Set controls as described in 2.2  
Confirm 100W CW output reading
- Unkey the transceiver and reverse the coaxial cable between the INPUT and DUMMY terminals on the AT-230. Move the FWD/REF switch to the REF position
- Transmit and adjust VR1 for previously confirmed 100W reading



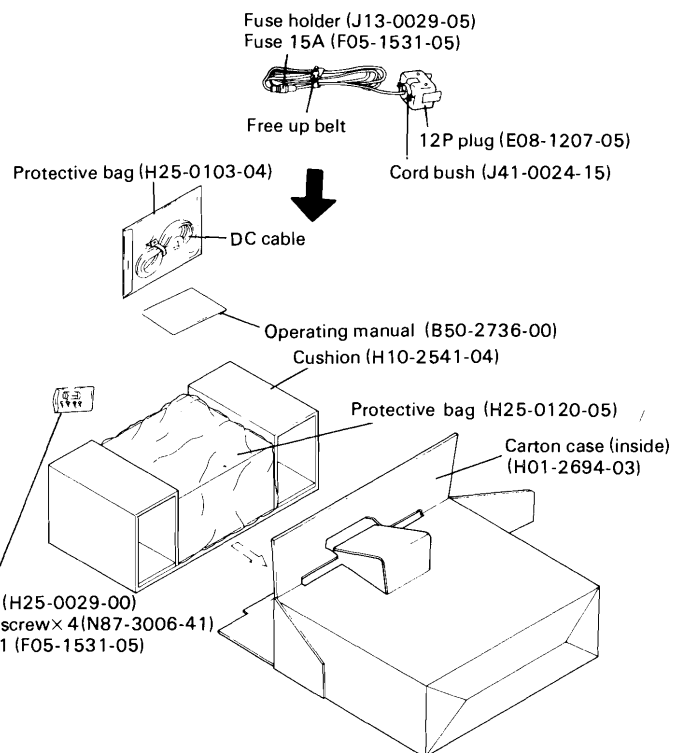
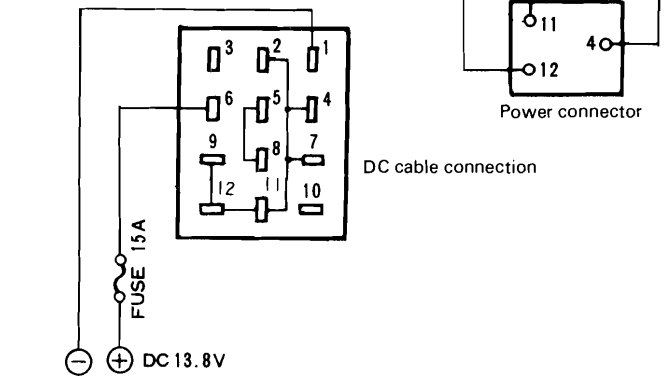
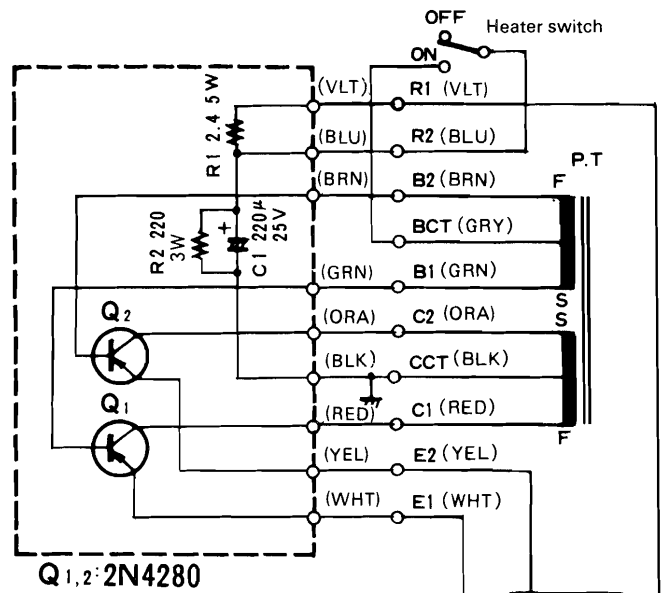
# DS-2 (W type only)

## SPECIFICATIONS

Semiconductor.. 2N4280 × 2  
 Rated Final Stage Input Power at 13.8 VDC.  
 SSB 130W PEP  
 CW 100W  
 Power Consumption  
 Receive:  
 Heaters OFF 0.8A  
 Heaters ON 4.5A  
 Transmit 15A  
 Power Supply 12–16 VDC (standard 13.8V)  
 Dimensions  
 W 80 mm ( 3 15" )  
 H 37 mm ( 1 46" )  
 D 69 mm ( 2 72" )  
 Weight 240g

## PARTS LIST

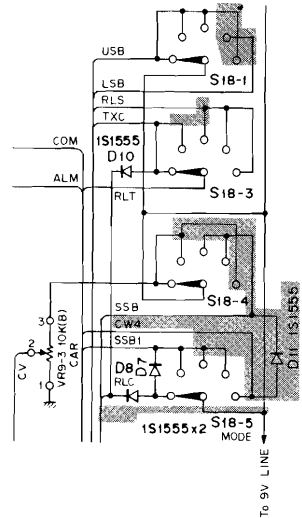
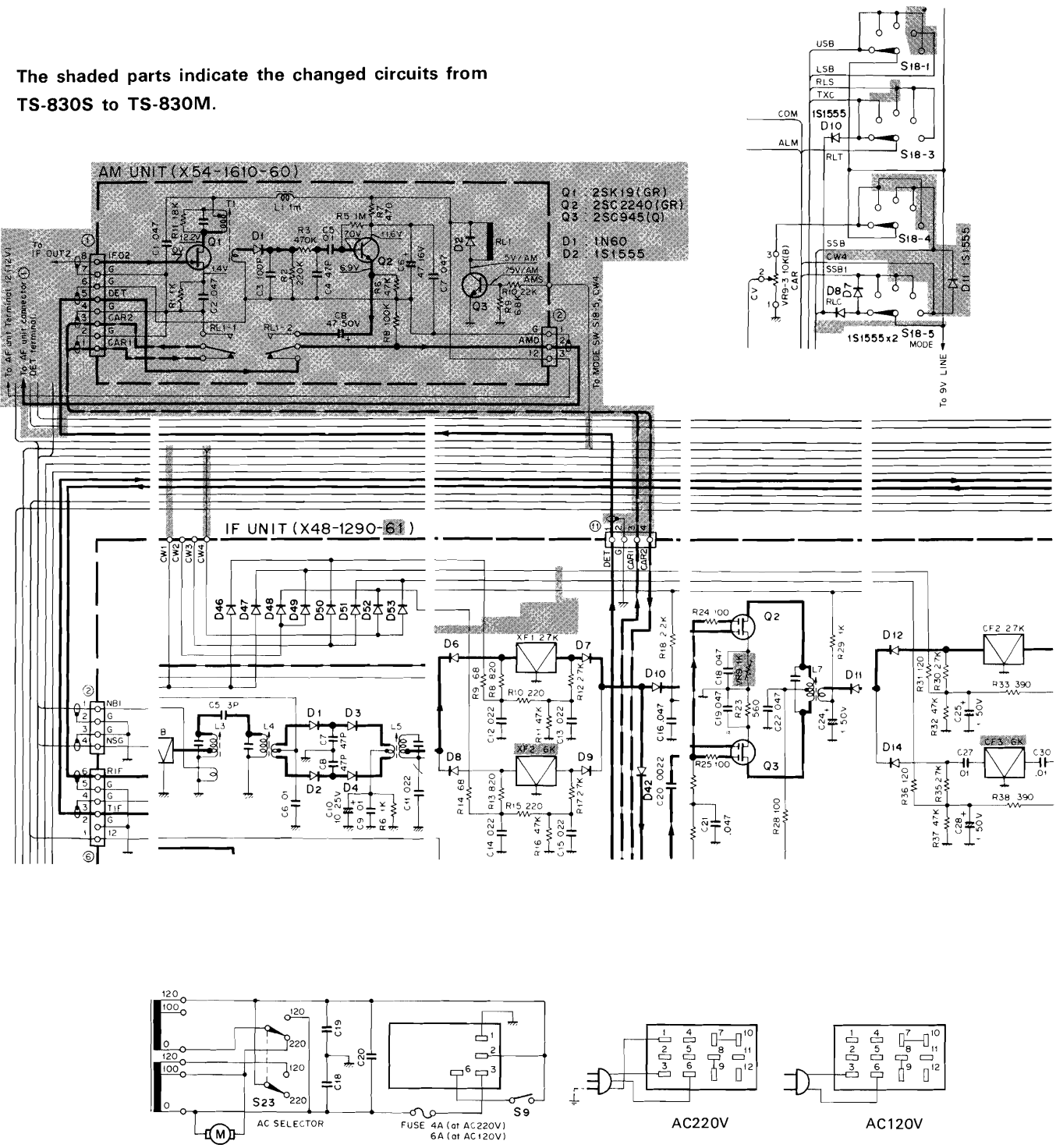
Ref. No.	Parts No.	Description	Re- marks
	B50-2736-00	Operating manual	☆
C1	CE02W1E221	C 220μF 25V	
	E08-1207-05	12P plug	
	E20-0513-05	5P terminal	
	F05-1531-05	Fuse 15A	
	F29-0414-04	Insulating washer	
	H01-2694-03	Carton case (inside)	☆
	H10-2541-04	Cushion	☆
	H25-0029-04	Protective bag	
	H25-0103-04	Protective bag	
	H25-0120-04	Protective bag	
	J13-0029-05	Fuse holder	
	J41-0024-15	Cord bush	
R1	R92-0121-05	Cement resistor 2.4Ω 5W	
R2	R92-0120-05	Cement resistor 220Ω 2.5W	
Q1,2	V30-1161-06	TR 2N4280	



Protective bag (H25-0029-00)  
 Self tapping screw × 4 (N87-3006-41)  
 Fuse 15A × 1 (F05-1531-05)

# TS-830M SCHEMATIC DIAGRAM (EXCEPT U.S.A. MARKET)

The shaded parts indicate the changed circuits from TS-830S to TS-830M.



AF Unit (X49-1140-00)

Con- nector No.	Termi- nal No.	Termi- nal	Remarks	Destination				
				Unit/switch	Con- nector No.	Termi- nal No.	Termi- nal	
①	1	GND	Detector input Bias voltage for SSB	IF unit	⑪	1	DET	
	2	DET						
	3	SSB						
	4	GND	VOX input Noise blanker input	IF unit	⑨	3	VXI	
	5	VXI						
	6	NBI STB						
②	1	AV2	Arm of AF gain control	AF gain control				
	2	GND	Top of AF gain control	AF gain control				
	3	AV1						
	4	GND	To ground in CW and CW NAR	MODE SW S18-6			STE	
	5	STE						
	6	KEY			MODE SW S18-6		KEY	
③	1	SP	Speaker internal	REMOTE socket		1	SP	
	2	GND	Side tone SW	KEY Jack		7	STS	
	3	STS						
④	1	SS	Stand by SW VOX switch to ground VOX on	REMOTE socket VOX SW		3	SS	
	2	VXS						
	3	VXD	VOX delay control	VOX delay control				
	4	VXG	VOX gain control	VOX gain control				
	5	GND	Speaker output	Phone jack			2	
	6	SP						
⑤	1	VR3	Final bias control	Bias control		3	VR3	
	2	KEY	Key jack	KEY jack		2	KEY	
	3	VR1	Final bias control	Bias control		1	VR1	
	4	AV	Anti VOX arm	Anti VOX control		2	AV	
	5	SS	Stand by SW	Stand by SW S17			SS	
	6	RL	Relay Voltage + 12.3V on TX + 9V	IF unit	⑩	3	RL	
	7	9		EXT VFO socket		3	9	
⑥	1	RB1	Bias for Q1 RF amp on RF unit	RF unit	⑧	2	RB1	
	2	GND	From Q18 on AF unit bias to MIXer	RF unit	⑥	3	MXB	
	3	MXB						
	4	TOF	TX stop signal for WARC	RF unit	⑥	1	TOF	
	5	DRB	Bias for control grid V1	RF unit	⑧	1	DRB	
⑦	1	XIT	Transmitter incremental tuning	XIT SW S2-1			XIT	
	2	TM	Meter select switch S13 arm	Meter SW S13			TM	
	3	RLT	Relay + 9V on TX	MODE SW S18-3			RLT	
	4	RSC	Receiver RIT ON	RIT SW S3-1			RSC	
	5	RLR	Relay + 9V on RX	MODE SW S18-5			RLR	
	6	M	Meter voltage	Meter				
	7	-6	Bias voltage -6V	RIT SW S3-1			RTI	
	8	RTI	RIT SW	VFO unit		2	RIT	
	9	RIT	RIT to VFO					
		FG	Bias for control grid Final	Final unit			FG	
⑧	1	XAL	Transmitter ALC	X.VTER socket		6	XAL	
	2	RAL	ALC input remote socket	REMOTE socket		6	RAL	
	3	VR2	Arm of TX bias control	Bias control				
⑨	1	NBV	Top of noise blanker VR	NB control				
	2	NBS	Noise blanker SW + 9V	NB SW S16				
	3	9	+ 9V in USB/LSB	MODE SW S18-4			SSB	
	4	SSB	Top of RF gain control	RF gain control				
	5	RF1						
⑩	1	NSG	Noise blanker gate signal	IF unit	②	4	NSG	
	2	GND	ALC voltage from Q19 on AF unit	IF unit	⑤	3	ALC	
	3	ALC						
	4	RB2	Receiver bias for IF unit	IF unit	⑨	5	RB2	
	5	TB	TX bias	IF unit	⑤	1	TB	
	6	SM	S meter signal	IF unit	⑨	2	SM	
	7	RS	Ground on RX	IF unit	⑤	2	RS	

IF unit (X48-1290-00)

①	1	IFO1		IF OUT 1 jack			IFO1
②	1	NBI	Noise blanker input	AF unit	①	6	NBI
	2	G	Noise blanker gate signal	AF unit	⑩	1	NSG
	3	G					
4	NSG						
③	1	-6	-6V	Processor SW S15-1			PRO
	2	PRO	Processor SW	VR9-2			COT
	3	COT	Arm of VR9-2 processor gain control				
	4	COM	Compression meter signal	Meter SW S13			COM

Con- nector No.	Termi- nal No.	Termi- nal	Remarks	Destination	
				Unit/switch	Con- nector No.
④	1	RLT	ALC meter DC signal + 9V	MODE SW S18-3 MODE SW S18-5 Meter SW S13	
	2	SSB1			
	3	ALM			
	4	9			
⑤	1	TB	Transmit bias Ground on TX ALC input from AF unit Q19	AF unit AF unit AF unit	
	2	RS			
	3	ALC			
		CW1		MODE SW S 18-5	
⑥	1	12	+ 12V		
	2	G	TX IF output	RF unit	
	3	TIF			
	4	G			
	5	G	RX IF input	RF unit	
	6	RIF			
⑦	1	MIC	MIC input  Top of MIC gain control Arm of MIC gain control	MIC jack  MIC gain control VR9-  PRO SW S15-2	
	2	G			
	3	G			
	4	MV1			
	5	MV2			
	6	G			
⑧	1	CV	Arm of carrier control	CAR control VR9-3	
	2	RFG	Arm of RF gain control	RF gain control VR3-1	
	3	AGS	AGC SW slow	AGC SW S11-2	
	4	AGO	AGC OFF	AGC SW S11-1	
	5	NCH	Notch frequency control voltage	Notch SW S1-1	
⑨	1	SSB	Bias voltage for SSB Smeter DC signal To VOX circuit	AF unit AF unit AF unit	
	2	SM			
	3	VXI			
	4	G			
	5	RB2			RX bias
⑩	1	IFO2	IF output for monitor	IF OUT 2 jack	
	2	G	TX bias for Q22 on IF unit from relay drive voltage		
	3	RL			
⑪	1	DET	Detector output	AF unit	
	2	G			
	3	CAR1			
	4	CAR2			
⑫	1	MX	Monitor ON SW	Monitor SW S5	
	2	MOE	Monitor signal ground	AF gain control VR3-2	
	3	MO	Monitor signal output	VBT control VR1-1	
	4	VBT	Arm of VR1-1		
⑬	1	CAR	CAR input	PLL unit	
	2	G			
⑭	1	210A	210 B +	Rectifier unit	
	2	G	210 B + 300 B +	Rectifier unit Rectifier unit	
	3	210B			
	4	300B			
⑮	1	300A	300 B +	RF unit	
	2	G	Output for AGC	RF unit	
	3	AGC			

PLL Unit (X50-1680-00)

①				Counter unit
②				Counter unit
③				Counter unit
④	1	G	Marker output	RF unit RF unit
	2	MKR		
⑤	1	G	VFO input	VFO unit VFO unit
	2	VFO		
		VCO	VCO output	RF unit
⑥	1	VFO	VFO input	EXT VFO socket
	2	G	EXT VFO Socket	EXT VFO Socket
	3	TXC		
⑦	1	G	Carrier output	IF unit
	2	CAR		
⑧	1	9	+ 9V	CAL SW S10 MODE SW S18-1 MODE SW S18-1 IF SHIFT VR2-2
	2	RLR	Relay + 9V on RX	
	3	MS	Calibrator SW S10	
	4	LSB	+ 9V on LSB mode	
	5	USB	+ 9V on TUN~USB	
	6	IFS	Arm of VR2-2 IF shift control	
	7	TXC	MODE SW S18-3	
	8	FXB	For FIX indicator	
	9	RLS	MODE SW S18-3	

# ABBREVIATION

## Counter Unit (X54-1540-00)

Unit/switch	Destination		
	Con- nector No.	Termi- nal No.	Termi- nal
MODE SW S18-3 MODE SW S18-5 Meter SW S13			RLT SSB1 ALM
AF unit	⑩	5	TB
AF unit	⑩	7	RS
AF unit	⑩	3	ALC
MODE SW S 18-5			CW1
RF unit	⑦	2	TIF
RF unit	⑤	2	RIF
MIC jack		1	
MIC gain control VR9-1 PRO SW S15-2			
CAR control VR9-3 RF gain control VR3-1 AGC SW S11-2 AGC SW S11-1 Notch SW S1-1			CV RFG AGS AGO NCH
AF unit AF unit AF unit	① ⑩ ①	3 6 5	SSB SM VXI
AF unit	⑩	4	RB2
IF OUT 2 jack			IFO2
AF unit	①	2	DET
Monitor SW S5 AF gain control VR3-2 VBT control VR1-1			MO VBT
PLL unit	⑦	2	CAR
Rectifier unit			210A
Rectifier unit Rectifier unit			210B 300B
RF unit	⑦	4	300A
RF unit	⑤	1	AGC

Con- nector No.	Termi- nal No.	Termi- nal	Remarks	Destination			
				Unit/switch	Con- nector No.	Termi- nal No.	Termi- nal
①	1 2 3	DH 0.5 12	Display hold 0.5 MHz shift +12V	DH SW S12 EXT VFO socket		6	0.5
②				PLL unit	②		
③				PLL unit	①		
④				RF unit	①		
⑤	1 2 3 4	28 28.5 29 29.5	To +0.5 SW S7-1 To +0.5 SW S7-2	RF unit RF unit	② ②	1 2	28 29

## VFO Unit (X40-1170-00)

	1 2 3 4 5	RLC RIT VFB GND VFO	From MODE SW S18-5 RIT Voltage input VFO B +9V VFO output	MODE SW S18-5 AF unit FIX SW S4 PLL unit	⑦ ⑤	9 2	RLC RIT VFB VFO
--	-----------------------	---------------------------------	--	---	--------	--------	--------------------------

## FINAL Unit (X56-1380-00)

		FG H SG IPM DRV	Control grid bias Heater voltage AC 12.3V Screen grid voltage IP meter voltage Drive input	AF unit Rectifier unit Meter SW S13 RF unit			FG PD2 DRV
--	--	-----------------------------	--	--	--	--	------------------

## RF unit (X44-1360-00)

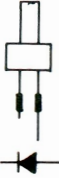
①				Counter unit	④		
②	1 2 3	28 29 9V	To + 0.5 SW S7-1 To + 0.5 SW S7-2 +9V	+ 0.5 SW S7-1 + 0.5 SW S7-2			
③	1 2 3	RLR G ANT	+ 9V on RX Receiver antenna input	RLR Line RF ATT SW S6-1			
④	1 2	G MKR	Marker input	PLL unit	④	2	MKR
⑤	1 2 3	AGC RIF G	AGC voltage RX IF output	IF unit IF unit	⑬ ⑥	3 6	AGC RIF
⑥	1 2 3	TOF 12 MXB	TX turn off signal +12V Bias for TX MIXer	AF unit AF unit	⑥ ⑥	4 3	TOF MXB
⑦	1 2 3 4	12 TIF G 300A	+12V TX IF input 300 B +	IF unit IF unit	⑥ ⑬	3 1	TIF 300A
⑧	1 2	DRB RB1	Control grid bias for V1 Bias for Q1 RF amp	AF unit AF unit	⑥ ⑥	5 1	DRB RB1
⑨	1 2	H 210A	Heater voltage AC 12.3V 210 B +				
⑩	1 2	G UV	Transverter output	X. VTER socket		7	UV
		NC DRV VCO NFB	Neutralization Drive output VCO input Negative feed back	Final tank circuit Final unit PLL unit Final tank circuit			DRV VCO

## Rectifier unit (X43-1370-00)

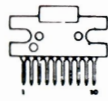
		HV	High voltage signal to METER	METER SW S13			HV
		800 300B 210B 210A STB -C	800 B + 300 B + 210 B + 210 B + Side tone voltage Common B -	AF unit			STB
		SG2 TUN	Screen grid voltage Screen grid low voltage for TUN	MODE SW S18-2 MODE SW S18-2			SG2 TUN
		12 SGS SG1 PD2 PD1	+12V To SG SW To MODE SW Screen grid voltage	SG SW S20 MODE SW S18-2 Final unit			SGS SG1 SG

Counter unit	③		
Counter unit	②		
Counter unit	②		
RF unit	④	1	G
RF unit	④	2	MKR
VFO unit		4	GND
VFO unit		5	VFO
RF unit			VCO
EXT VFO socket		1	VFO
EXT VFO Socket		4	TXC
IF unit	⑬	1	CAR
CAL SW S10 MODE SW S18-1 MODE SW S18-1 IF SHIFT VR2-2			LSB USB IFS
MODE SW S18-3 FIX IND. D2 MODE SW S18-3			TXC RLS

SLP-144



HA1368R



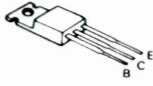
TLR-205



TA7302P



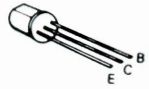
2SA473 (Y)



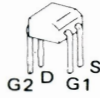
MV-13



2SA562 (Y)



3SK73 (GR)



2SA1015 (Y)

2SC945 (Q)

2SC1515 (K)

2SC1675 (L)

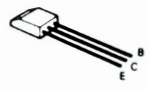
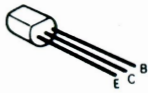
2SC1775 (E)

2SC1815 (BL) (GR) (Y)

2SC1923 (O)

2SC1959 (Y)

2SC2240 (GR)

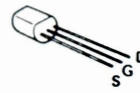


2SK19 (BL) (GR) (Y)

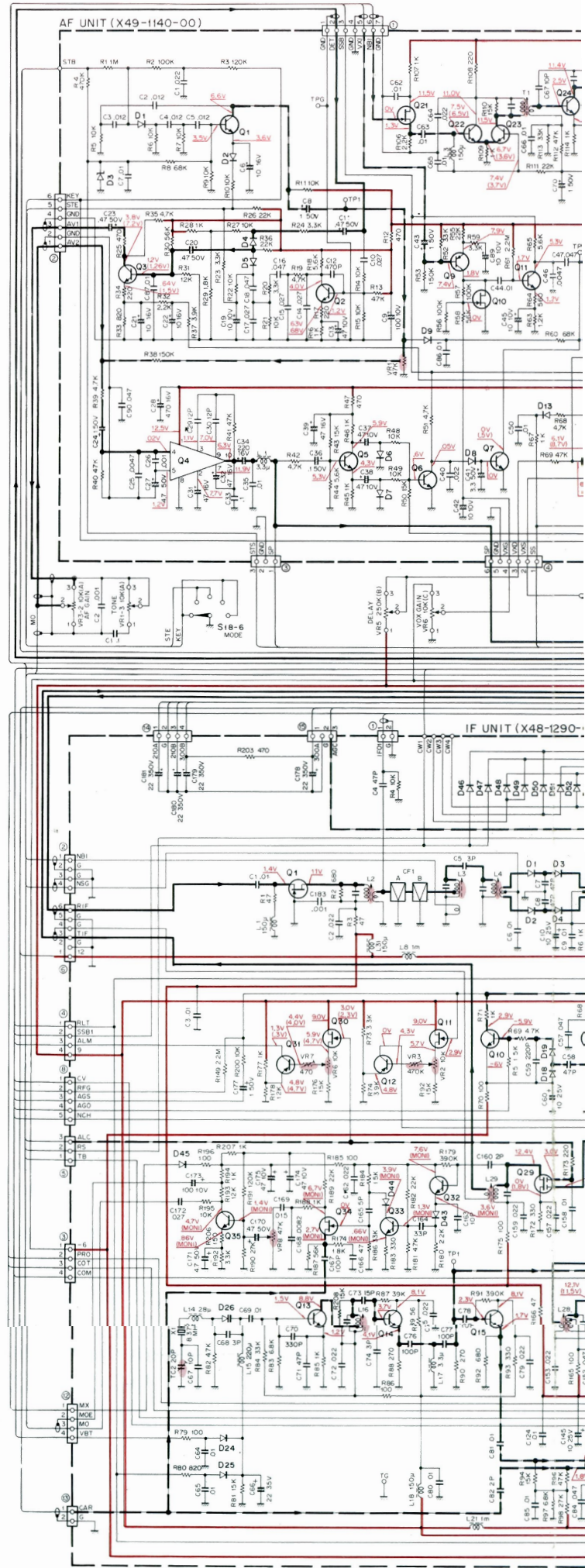
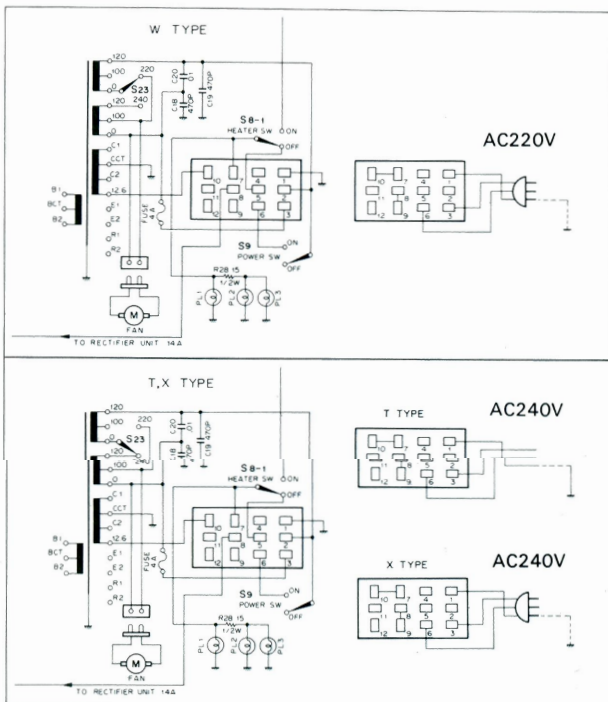
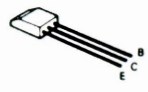


2SK30A (GR) (O)

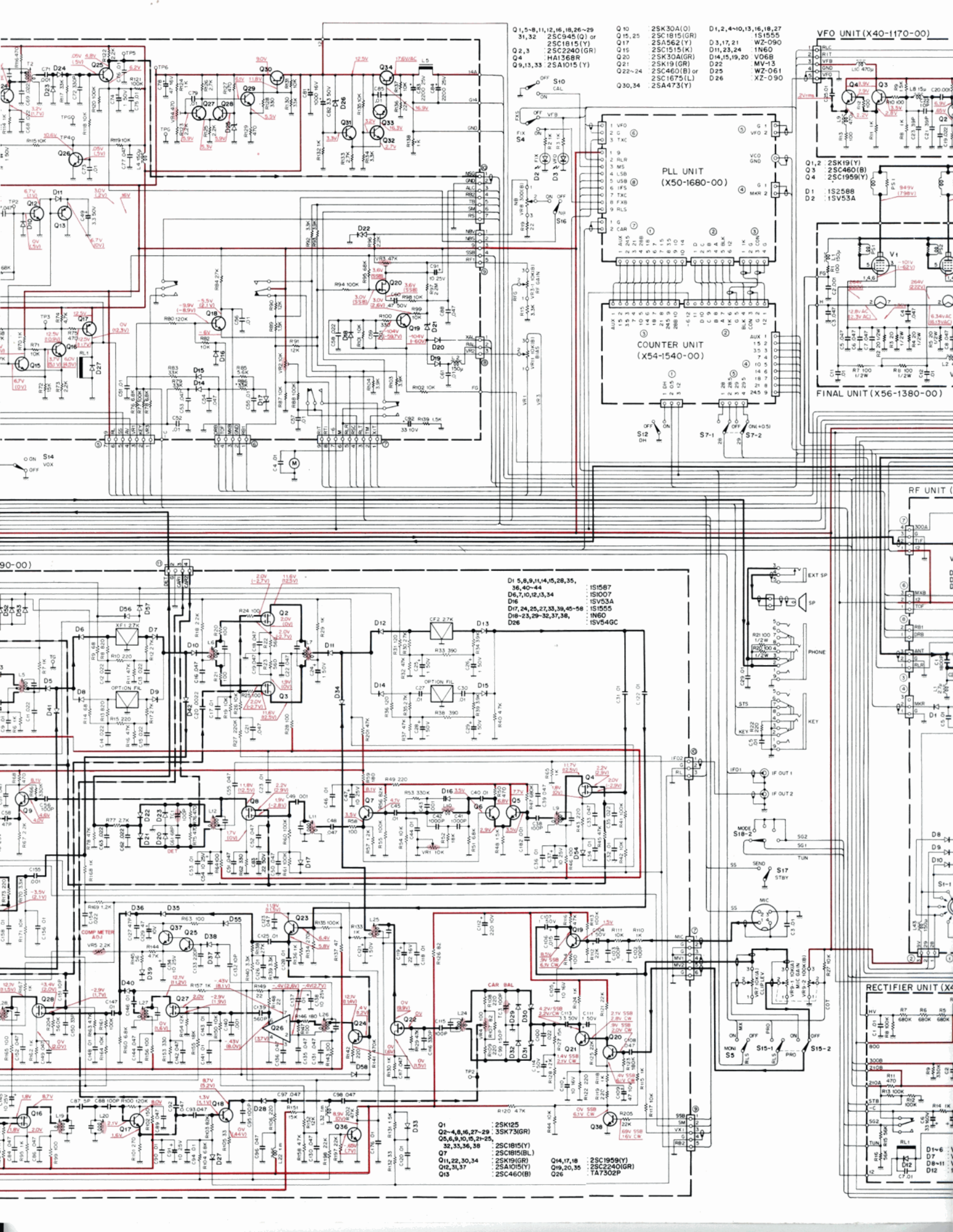
2SK125



2SC460 (B)



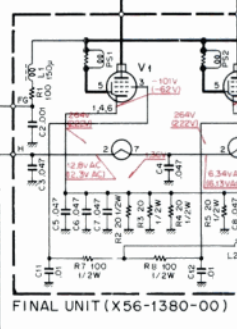
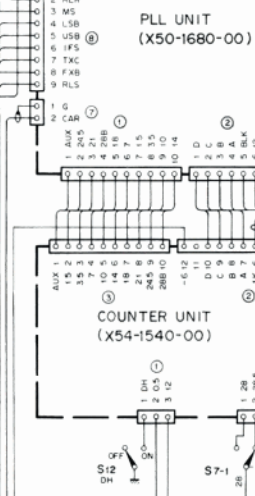
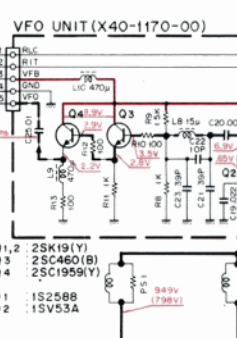




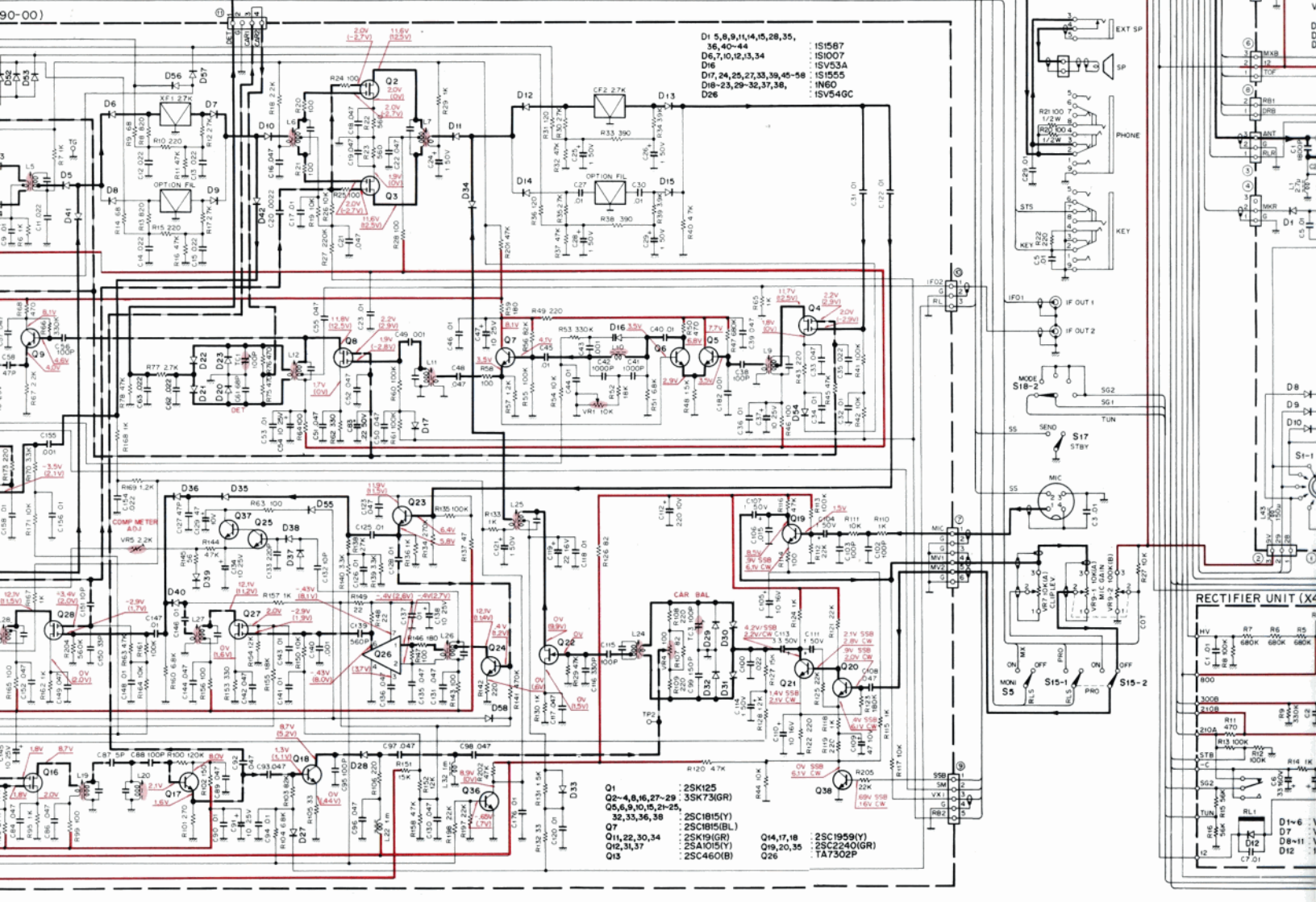
Q 1,5-8,11,12,16,18,26-29, 31,32 2SK30A(O)  
 Q 2,3 2SC1815(GR)  
 Q 4 2SC1815(Y)  
 Q 9,13,33 2SA1015(Y)

Q 10 2SK30A(O)  
 Q 15,25 2SC1815(GR)  
 Q 17 2SA562(Y)  
 Q 18 2SC1815(K)  
 Q 20 2SK30A(GR)  
 Q 21 2SK19(GR)  
 Q 22-24 2SC460(B) or 2SC1675(L)  
 Q 30,34 2SA473(Y)

D 1,2,4-10,13,16,18,27 1S1555  
 D 3,17,21 WZ-090  
 D 11,23,24 1N60  
 D 14,15,19,20 V06B  
 D 22 MV-13  
 D 25 WZ-061  
 D 26 XZ-090

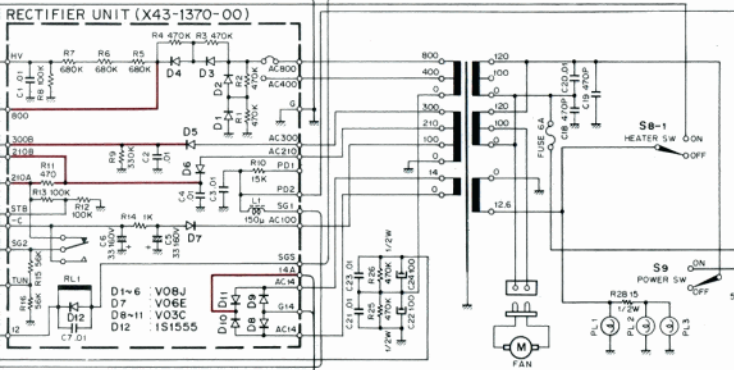
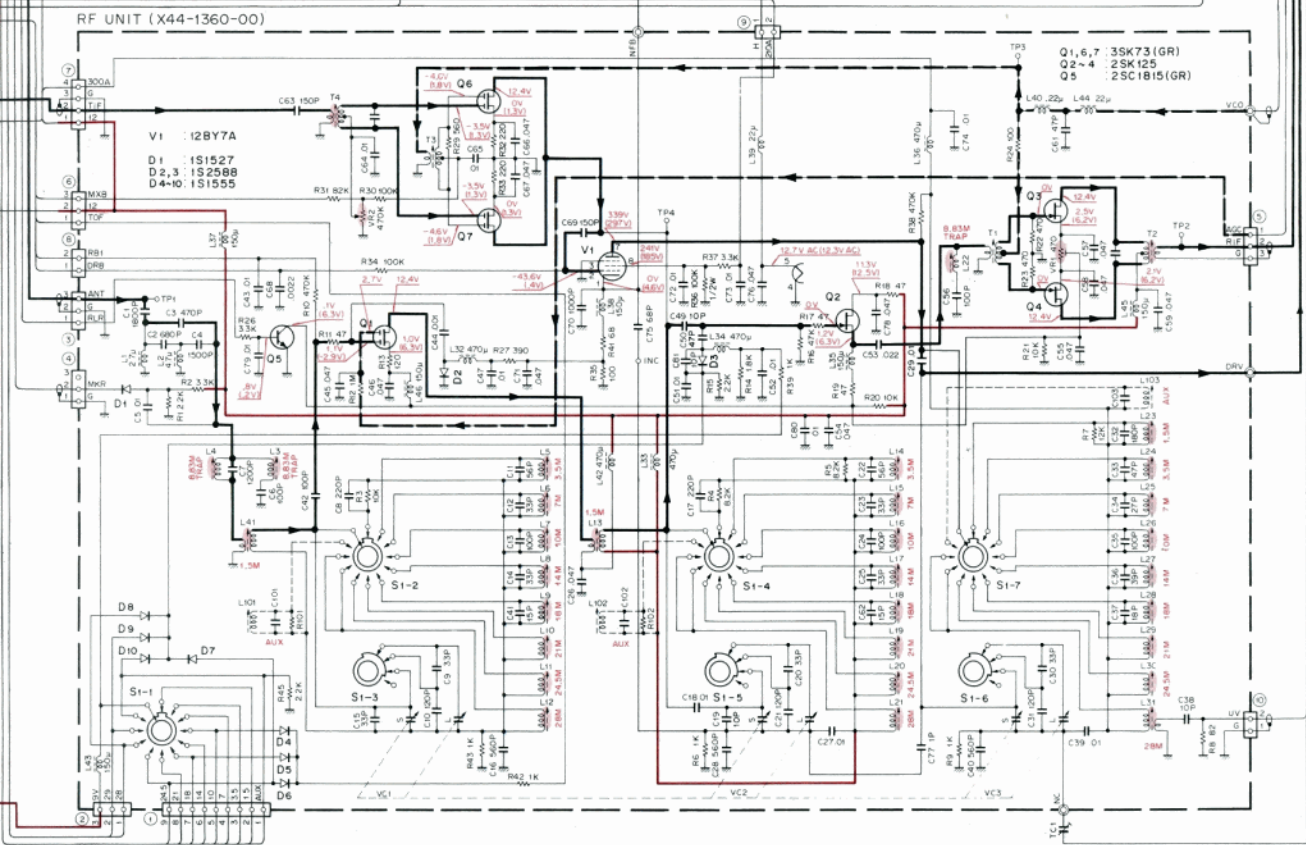
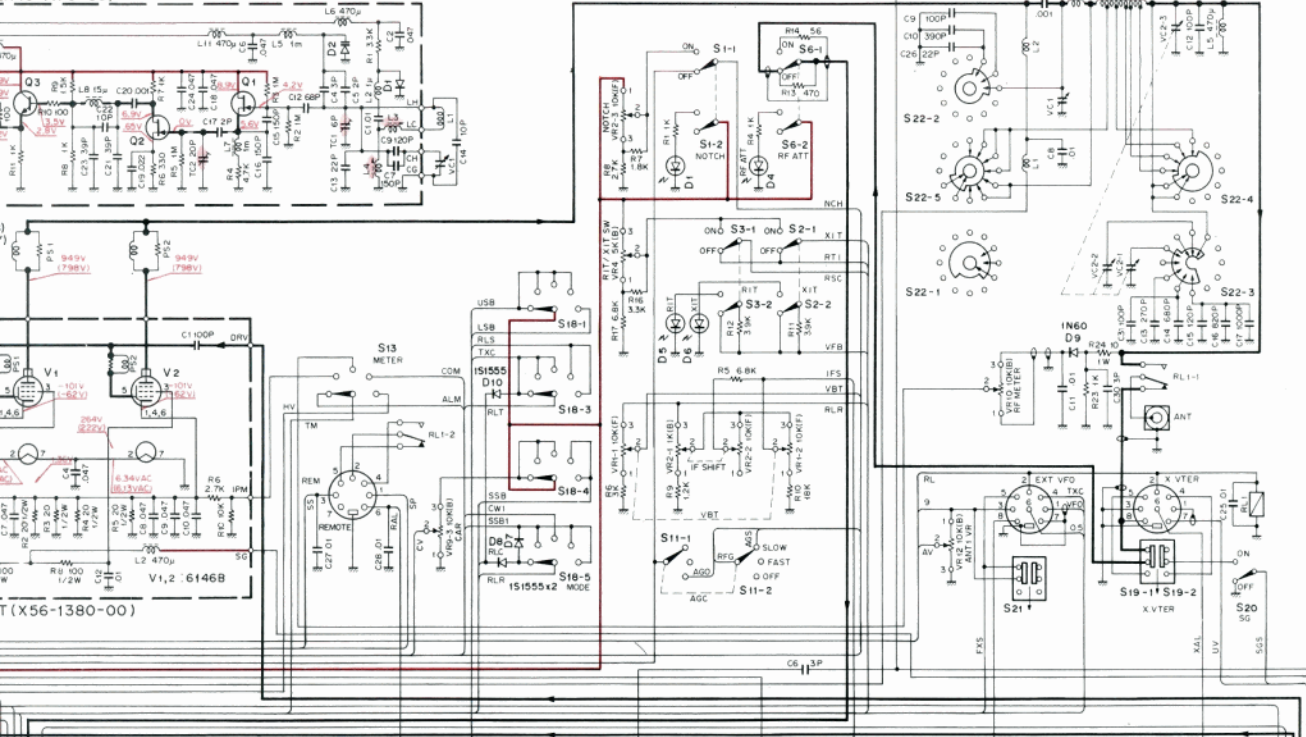


D 1,5,9,9,11,4,15,28,35, 36,40-44 1S1567  
 D 6,7,10,12,13,34 1S1007  
 D 17, 24,25,27,33,39,45-58 1S1555  
 D 18-23,29-32,37,38, D26 1N60  
 1S1549C





(X40-1170-00)

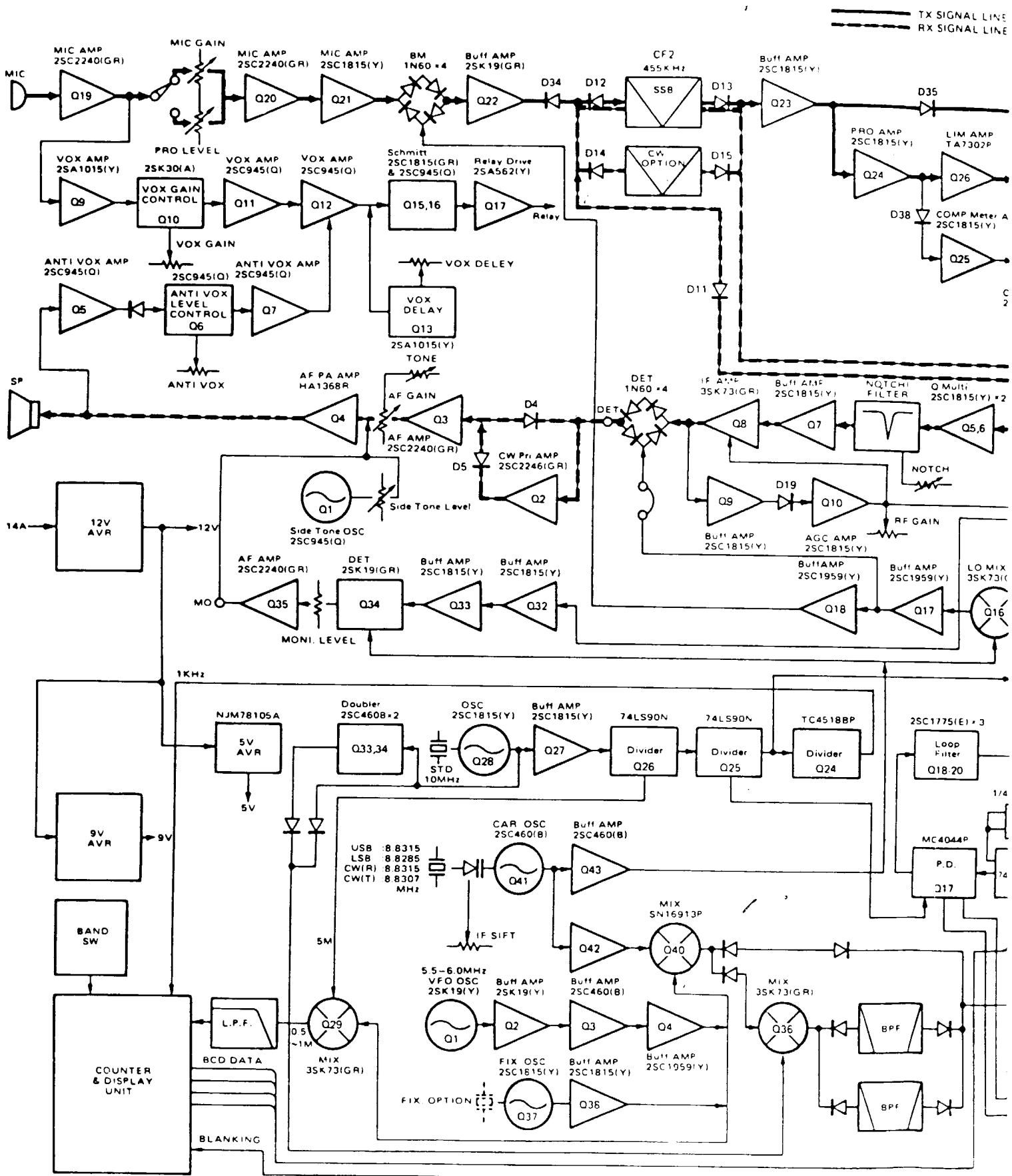


NOTE: Circuit and ratings may change without notice due to developments in technology.

- Signal line
- - - Control line
- Common DC line

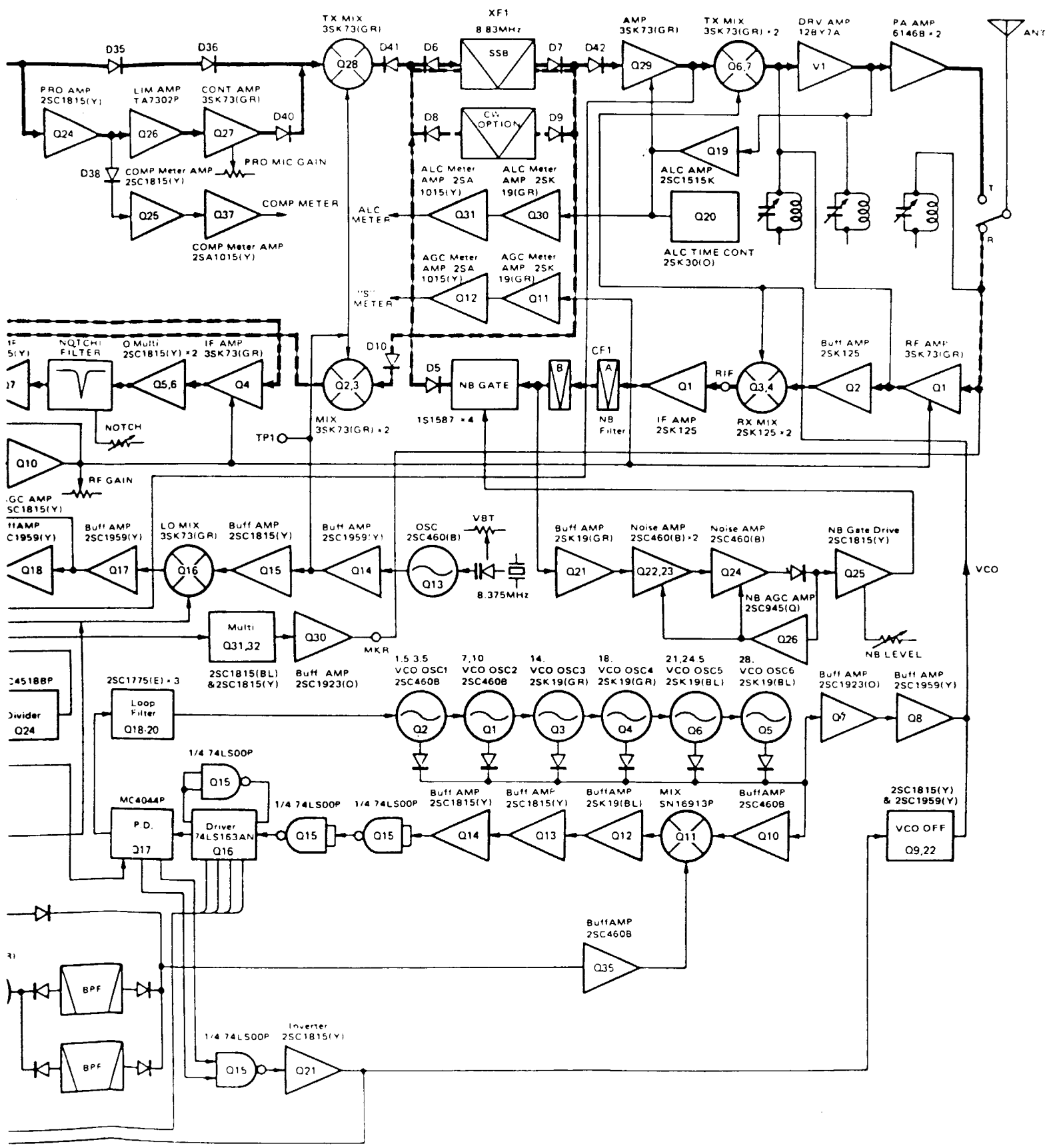
Voltage measurement conditions  
 $f = 14.175 \text{ MHz}$   
 RX no signal  
 ( ) in TX





# S-830S BLOCK DIAGRAM

— TX SIGNAL LINE  
- - - RX SIGNAL LINE



# SP-230

## SPECIFICATIONS

**Speaker used:** 12 cm dia.  
**Rated Input:** 2 Watts  
**Impedance:** 8 $\Omega$   
**Frequency response:** 100Hz to 5kHz.  
**Filter cut-off frequency,**  
**LOW:** 400Hz, -3dB.  
**HIGH 1:** 3kHz, -3dB.  
**HIGH 2:** 1.5kHz, -3dB.  
**HIGH 1 + HIGH 2:** 1 kHz, -3dB.  
**Filter attenuation:** -6dB/oct.  
**Dimensions:**  
W 180 mm (7-1/16")  
H 133 mm (5-1/4")  
D 287 mm (11-5/16")  
**Net weight:** 1.8 kg. (4.0 lbs.)  
**Accessories furnished:** Speaker cord, 1 pc.  
(E14-0101-05)  
Extension foot, 2 pcs.  
(J02-0049-14)  
Screw, M4 x 12, 2 pcs.  
(N30-4012-41)  
1 pin plug, 2 pcs.  
(E20-1610-05)

## PARTS LIST

Ref No.	Parts No.	Description	Re- marks
	A01-0786-03	Case (upper)	
	A01-0789-02	Case (lower)	☆
	A20-2399-05	Panel (T)	☆
	A20-2400-05	Panel (K)(W)	☆
	B46-0058-00	Warranty card (K)	
	B50-2759-00	Operating manual (K)(W)	☆
	B50-2760-00	Operating manual (T)	☆
	E11-0404-05	Phone jack	
	E12-0001-05	Phone plug	
	E13-0361-05	3P Pin jack	
	E14-0101-05	1P Pin plug	
	E30-1610-05	Connector with lead	
	G53-0502-04	Packing	
	H01-2723-04	Carton (inside)(K)(W)	☆
	H01-2724-04	Carton case (inside)(T)	☆
	H10-2523-02	Packing fixture (F)	
	H10-2525-02	Packing fixture (R)	
	H20-0276-03	Protective cover	
	H25-0049-03	Protective bag	
	J02-0049-14	Foot	
	K29-0716-04	Push knob	
	L79-0443-25	Filter	
	RS14AB3D8R2J	Solid 8.2 $\Omega$ 2W	
	S40-2414-05	Push switch INPUT	
	S42-3401-05	Push switch LOW, HIGH 1, 2	
	T06-0011-05	Speaker	

A product of  
**TRIO-KENWOOD CORPORATION**  
17-5, 2-chome, Shibuya, Shibuya-ku, Tokyo 150, Japan

**TRIO-KENWOOD COMMUNICATIONS, INC.**  
1111, West Walnut Street, Compton, California, 90220, U.S.A.  
**TRIO-KENWOOD COMMUNICATIONS, GmbH**  
D-6374 Steinbach TS, Industriestrasse 8A, West Germany  
**TRIO-KENWOOD(AUSTRALIA)PTY. LTD.**  
30 Whiting Street, Artarmon, Sydney N.S.W Australia 2064

# TS-830S,M SERVICE MANUAL ERRATA

Voltages in this Schematic Diagram are correct. (Refer to TS-830S, M page 63.)

