

**ICOM**

**SERVICE  
MANUAL**

TRIBAND FM TRANSCEIVER

**IC-4100H**

---

---

---

---

---

---

---

---

Icom Inc.

---

# ADJUSTMENT PROCEDURES

## PLL ADJUSTMENT

ADJUSTMENT		ADJUSTMENT CONDITIONS	MEASUREMENT		VALUE	ADJUSTMENT POINT	
			UNIT	LOCATION		UNIT	ADJUST
144 MHz LOCK VOLTAGE	1	<ul style="list-style-type: none"> <li>• Displayed frequency: 145.000 MHz</li> <li>• Simplex</li> <li>• Transmitting and receiving</li> </ul>	VCO-A	Connect the digital multimeter or oscilloscope to CP-A1.	11 V	VCO-A	L4
144 MHz REFERENCE FREQUENCY	1	<ul style="list-style-type: none"> <li>• Displayed frequency: 145.000 MHz</li> <li>• Connect the RF power meter or a 50 <math>\Omega</math> dummy load to [144 MHz ANT].</li> </ul>	Rear panel	Loosely couple the frequency counter to the power meter.	145.0000 MHz	VCO-A	C1
430 (440) MHz LOCK VOLTAGE	1	<ul style="list-style-type: none"> <li>• Push and hold the 430 (440) MHz band's tuning dial until "-140-" appears.</li> <li>• Displayed frequency: 145.000 MHz</li> <li>• Receiving</li> </ul>	VCO-B	Connect the digital multimeter or oscilloscope to CP-B1.	11 V	VCO-B	L4
430 (440) MHz REFERENCE FREQUENCY	1	<ul style="list-style-type: none"> <li>• Displayed frequency: 440.000 MHz</li> <li>• Connect the RF power meter or a 50 <math>\Omega</math> dummy load to [430 (440) MHz ANT].</li> </ul>	Rear panel	Loosely couple the frequency counter to the power meter.	440.0000 MHz	—	Confirm
1200 MHz REFERENCE FREQUENCY	1	<ul style="list-style-type: none"> <li>• Displayed frequency: 1280.000 MHz</li> <li>• Connect the RF power meter or a 50 <math>\Omega</math> dummy load to [1200 MHz ANT].</li> </ul>	Rear panel	Loosely couple the frequency counter to the power meter.	1280.0000 MHz	VCO-C	R81

\* This output level is indicated as SSG's open circuit.

CCW: Counterclockwise.

# RECEIVER ADJUSTMENT

ADJUSTMENT	ADJUSTMENT CONDITIONS	MEASUREMENT		VALUE	ADJUSTMENT POINT	
		UNIT	LOCATION		UNIT	ADJUST
144 MHz SENSITIVITY	<ul style="list-style-type: none"> <li>• Displayed frequency: 145.000 MHz</li> <li>• Connect the SSG to the antenna connector and set as:  Level : 1.0 <math>\mu</math>V*  (-107 dBm)  Modulation: 1 kHz  Deviation : <math>\pm</math>3.5 kHz</li> <li>• Receiving</li> <li>• Squelch: Open</li> </ul>	MAIN-A	Connect the digital multimeter or oscilloscope to CP-A2.	Max. voltage	MAIN-A	R51 max. clockwise
				Max. voltage		Adjust in sequence L17, L16, L15
				Max. voltage		L13
144 MHz S-INDICATOR	<ul style="list-style-type: none"> <li>• Displayed frequency: 145.000 MHz</li> <li>• Connect the SSG to the antenna connector and set as:  Level : 1.0 <math>\mu</math>V*  (-107 dBm)  Modulation: 1 kHz  Deviation : <math>\pm</math>3.5 kHz</li> <li>• Receiving</li> </ul>	Function display	144 MHz S/RF indicator	4 dots	MAIN-A	R51
430 (440) MHz SENSITIVITY	<ul style="list-style-type: none"> <li>• Displayed frequency:  445.000 MHz (U.S.A.)  435.000 MHz (non-U.S.A.)</li> <li>• Connect the SSG to the antenna connector and set as:  Level : 1.0 <math>\mu</math>V*  (-107 dBm)  Modulation: 1 kHz  Deviation : <math>\pm</math>3.5 kHz</li> <li>• Receiving</li> </ul>	MAIN-B	Connect the digital multimeter or oscilloscope to CP-B2.	Max. voltage	MAIN-B	Adjust in sequence C96, L12
				Max. voltage		Adjust in sequence L30, L29
430 (440) MHz S-INDICATOR	<ul style="list-style-type: none"> <li>• Displayed frequency:  445.000 MHz (U.S.A.)  435.000 MHz (non-U.S.A.)</li> <li>• Connect the SSG to the antenna connector and set as:  Level : 1.0 <math>\mu</math>V*  (-107 dBm)  Modulation: 1 kHz  Deviation : <math>\pm</math>3.5 kHz</li> <li>• Receiving</li> </ul>	Function display	430 (440) MHz S/RF indicator	4 dots	MAIN-B	R53
1200 MHz SENSITIVITY	<ul style="list-style-type: none"> <li>• Displayed frequency: 1280.00 MHz</li> <li>• Connect the SSG to the antenna connector and set as:  Level : 1.0 <math>\mu</math>V*  (-107 dBm)  Modulation: 1 kHz  Deviation : <math>\pm</math>3.5 kHz</li> <li>• Receiving</li> <li>• Squelch: Open</li> </ul>	MAIN-C	Connect the digital multimeter or oscilloscope to CP-C1.	Max. voltage	MAIN-C	Adjust in sequence L4, L3, L2
1200 MHz S-INDICATOR	<ul style="list-style-type: none"> <li>• Displayed frequency: 1280.000 MHz</li> <li>• Connect the SSG to the antenna connector and set as:  Level : 1.0 <math>\mu</math>V*  (-107 dBm)  Modulation: 1 kHz  Deviation : <math>\pm</math>3.5 kHz</li> <li>• Receiving</li> </ul>	Function display	1200 MHz S/RF indicator	10 dots	MAIN-C	R120

\* This output level is indicated as SSG's open circuit.

CCW: Counterclockwise.

# TRANSMITTER ADJUSTMENT

ADJUSTMENT	ADJUSTMENT CONDITIONS	MEASUREMENT		VALUE	ADJUSTMENT POINT		
		UNIT	LOCATION		UNIT	ADJUST	
144 MHz OUTPUT POWER	1	<ul style="list-style-type: none"> <li>• Displayed frequency: 145.000 MHz</li> <li>• Output power : High</li> <li>• Simplex</li> <li>• Transmitting</li> </ul>	Top panel	Connect the RF power meter to [144 MHz ANT].	50 W	MAIN-A	R40
	2						<ul style="list-style-type: none"> <li>• Output power : Low 1</li> </ul>
144 MHz DEVIATION	1	<ul style="list-style-type: none"> <li>• Displayed frequency: 145.000 MHz</li> <li>• Connect the audio generator to the microphone connector (pin 4) and set as: 100 mV/1.0 kHz</li> <li>• Connect the FM deviation meter to the antenna connector and set as: HPF : 50 Hz LPF : 20 kHz De-emphasis : OFF Detector : (P – P)/2</li> <li>• Transmitting</li> </ul>	Rear panel	Connect the FM deviation meter to [144 MHz ANT] through the attenuator.	± 4.8 kHz	MAIN-A	R19
430 (440) MHz OUTPUT POWER	1	<ul style="list-style-type: none"> <li>• Displayed frequency: 445.000 MHz (U.S.A. ) 435.000 MHz (non-U.S.A. )</li> <li>• Output power : High</li> <li>• Simplex</li> <li>• Transmitting</li> </ul>	Top panel	Connect the RF power meter to [430 (440) MHz ANT].	35 W	MAIN-B	R42
	2						<ul style="list-style-type: none"> <li>• Output power : Low 1</li> </ul>
430 (440) MHz DEVIATION	1	<ul style="list-style-type: none"> <li>• Displayed frequency: 145.000 MHz</li> <li>• Connect the audio generator to the microphone connector (pin 4) and set as: 100 mV/1.0 kHz</li> <li>• Connect the FM deviation meter to the antenna connector and set as: HPF : 50 Hz LPF : 20 kHz De-emphasis : OFF Detector : (P – P)/2</li> <li>• Transmitting</li> </ul>	Rear panel	Connect the FM deviation meter to [430 (440) MHz ANT] through the attenuator.	± 4.8 kHz	MAIN-B	R19
1200 MHz OUTPUT POWER	1	<ul style="list-style-type: none"> <li>• Displayed frequency: 1280.000 MHz</li> <li>• Output power : High</li> <li>• Simplex</li> <li>• Transmitting</li> </ul>	Top panel	Connect the RF power meter to [1200 MHz ANT].	10 W	MAIN-C	R42
	2						<ul style="list-style-type: none"> <li>• Output power : Low 1</li> </ul>
1200 MHz DEVIATION	1	<ul style="list-style-type: none"> <li>• Displayed frequency: 1280.000 MHz</li> <li>• Connect the audio generator to the microphone connector (pin 4) and set as: 100 mV/1.0 kHz</li> <li>• Connect the FM deviation meter to the antenna connector and set as: HPF : 50 Hz LPF : 20 kHz De-emphasis : OFF Detector : (P – P)/2</li> <li>• Transmitting</li> </ul>	Rear panel	Connect the FM deviation meter to [1200 MHz ANT] through the attenuator.	± 4.8 kHz	MAIN-C	R2

CW: Clockwise.

## TRANSMITTER ADJUSTMENT (continued)

ADJUSTMENT	ADJUSTMENT CONDITIONS	MEASUREMENT		VALUE	ADJUSTMENT POINT	
		UNIT	LOCATION		UNIT	ADJUST
EXTERNAL EQUIPMENT DEVIATION	<ul style="list-style-type: none"> <li>• Displayed frequency: 445.000 MHz (U.S.A.) 435.000 MHz (non-U.S.A.)</li> <li>• Connect the audio generator to the "I" terminal on the LOGIC unit and set as: 20 mV/1 kHz</li> <li>• Connect "P" terminal and "G" terminal on the logic unit to transmit.</li> </ul>	Rear panel	Connect the FM deviation meter to [430 MHz ANT].	$\pm 1.5$ kHz	LOGIC	R52
88.5 Hz TONE DEVIATION (non-U.S.A.)	<ul style="list-style-type: none"> <li>• Displayed frequency: 435.000 MHz (non-U.S.A.)</li> <li>• Push and hold [DUP/TONE] several times until "T" appears.</li> </ul>	Rear panel	Connect the FM deviation meter to [430 MHz ANT].	$\pm 0.8$ kHz	LOGIC	R25
SUB-AUDIBLE TONE DEVIATION (U.S.A.)	<ul style="list-style-type: none"> <li>• Displayed frequency: 445.000 MHz (U.S.A.)</li> <li>• Push and hold [DUP/TONE] several times until "T" appears.</li> </ul>	Rear panel	Connect the FM deviation meter to [440 MHz ANT].	$\pm 0.8$ kHz	LOGIC	R15
Optional UT-76 TONE DEVIATION	<ul style="list-style-type: none"> <li>• Displayed frequency: 445.000 MHz (U.S.A.) 435.000 MHz (non-U.S.A.)</li> <li>• Push and hold [DUP/TONE] several times until "T" appears.</li> </ul>	Rear panel	Connect the FM deviation meter to [430 (440) MHz ANT].	$\pm 0.8$ kHz	Optional UT-76	R35
An optional UT-76 TONE SQUELCH UNIT is required.						

# PARTS LIST

## [DISPLAY UNIT]

REF. NO.	ORDER NO.	DESCRIPTION	
IC1	1130004190	S.IC	LC7582A
IC2	1130004190	S.IC	LC7582A
IC3	1130004190	S.IC	LC7582A
D1	1750000270	S.DIODE	1SS301 (TE85R)
D2	1750000270	S.DIODE	1SS301 (TE85R)
D3	1750000270	S.DIODE	1SS301 (TE85R)
D4	1750000270	S.DIODE	1SS301 (TE85R)
D5	1750000270	S.DIODE	1SS301 (TE85R)
D6	1750000270	S.DIODE	1SS301 (TE85R)
D7	1750000270	S.DIODE	1SS301 (TE85R)
D8	1750000270	S.DIODE	1SS301 (TE85R)
R1	7030003650	S.RESISTOR	ERJ3GEYJ 563 V (56 kΩ)
R2	7030003650	S.RESISTOR	ERJ3GEYJ 563 V (56 kΩ)
R3	7030003650	S.RESISTOR	ERJ3GEYJ 563 V (56 kΩ)
C1	4030006830	S.CERAMIC	C1808 SL 1H 331J-T-A
C2	4030006830	S.CERAMIC	C1808 SL 1H 331J-T-A
C3	4030006830	S.CERAMIC	C1808 SL 1H 331J-T-A
C4	4030006830	S.CERAMIC	C1808 JF 1C 104Z-T-A
C5	4030006830	S.CERAMIC	C1808 JF 1C 104Z-T-A
C6	4030006830	S.CERAMIC	C1808 JF 1C 104Z-T-A
DS1	5080000150	LAMP	HRS-7219A
DS2	5080000150	LAMP	HRS-7219A
DS3	5080000150	LAMP	HRS-7219A
DS4	5080000150	LAMP	HRS-7219A
DS5	5080000150	LAMP	HRS-7219A
DS6	5080000150	LAMP	HRS-7219A
DS7	5030000870	LCD	FTD-10854AAH
W1	7030000010	S.JUMPER	MCR10EZHZ JPW (000)
W2	7030000010	S.JUMPER	MCR10EZHZ JPW (000)
W3	7030000010	S.JUMPER	MCR10EZHZ JPW (000)
W4	7030000010	S.JUMPER	MCR10EZHZ JPW (000)
J1	6510014950	S.CONNECTOR	52271-1890
S1	2260001680	S.SWITCH	SKQDPB [SPCH/MW]
S2	2260001680	S.SWITCH	SKQDPB [SET/LOCK]
S3	2260001680	S.SWITCH	SKQDPB 144 MHz [SQL/M.SQL]
S4	2260001680	S.SWITCH	SKQDPB 144 MHz [M/CALL/PRI0]
S5	2260001680	S.SWITCH	SKQDPB 144 MHz [V/MHz]
S6	2260001680	S.SWITCH	SKQDPB [DTMF/MON]
S7	2260001680	S.SWITCH	SKQDPB [DUP/TONE]
S8	2260001680	S.SWITCH	SKQDPB 430 (440) MHz [SQL/M.SQL]
S9	2260001680	S.SWITCH	SKQDPB 430 (440) MHz [M/CALL/PRI0]
S10	2260001680	S.SWITCH	SKQDPB 430 (440) MHz [V/MHz]
S11	2260001680	S.SWITCH	SKQDPB [LOW/ATT/AFC]
S12	2260001680	S.SWITCH	SKQDPB 1200 MHz [SQL/M.SQL]
S13	2260001680	S.SWITCH	SKQDPB 1200 MHz [M/CALL/PRI0]
S14	2260001680	S.SWITCH	SKQDPB 1200 MHz [V/MHz]

## [DISPLAY UNIT]

REF. NO.	ORDER NO.	DESCRIPTION	
EP1	0910036223	PCB	B 3532C
EP3	8930027580	LCD CONTACT	SRCN-1126W
MP1	8010012800	HOLDER	1126 LCD holder
MP2	8010012791	PANEL	1126 LCD reflector-1
MP4	8310026780	SCREEN	1126 LCD filter
MP5	8930025160	RUBBER	1126 LCD rubber
MP6	8930018940	SPACER	Lamp spacer (A)
MP7	8930025120	RUBBER	1126 lamp rubber
MP8	8930027030	PLATE	1126 lamp cover
MP9	8510008320	PLATE	1126 ground contact

## [CONTROL UNIT]

REF. NO.	ORDER NO.	DESCRIPTION	
IC1	1110001550	S.IC	S-8054ALB-LM-T1
IC2	1130005820	S.IC	TC4S584F (TE85R)
IC3	1140002900	S.IC	μPD78214GC-202-AB8
IC4	1130005810	S.IC	BU4094BF-T1
IC5	1180000970	S.IC	AN78L05M-(E1)
IC6	1130005720	S.IC	TC7W04F (TE12L)
IC7	1180000990	S.IC	AN78L08M-(E1)
IC8	1130006900	S.IC	MC74HC373AF
IC9	1130003920	S.IC	TC4S68F (TE85R)
IC10	1130006010	S.IC	HM8264ALFP-L
IC11	1140002910	S.IC	μPD7564AG-530
IC13	1110000960	S.IC	NJM4558M (T1)
IC18	1130005820	S.IC	TC4S584F (TE85R)
IC21	1110002410	S.IC	NJM2406F (TE1)
IC24	1130005820	S.IC	TC4S584F(TE85R)
Q1	1520000270	S.TRANSISTOR	2SB1182 TL Q
Q3	1530002840	S.TRANSISTOR	2SC4116-Y (TE85R)
Q5	1530002840	S.TRANSISTOR	2SC4116-Y (TE85R)
Q6	1540000250	S.TRANSISTOR	2SD999-T2 CK
Q7	1510000700	S.TRANSISTOR	2SA1736 (TE12R)
Q8	1590000430	S.TRANSISTOR	DTC144EU T107
Q9	1530002840	S.TRANSISTOR	2SC4116-Y (TE85R)
Q10	1530002840	S.TRANSISTOR	2SC4116-Y (TE85R)
Q12	1590000430	S.TRANSISTOR	DTC144EU T107
Q14	1590001390	S.FET	2SJ144-Y (TE85R)
Q20	1590000720	S.TRANSISTOR	DTA144EU T107
Q21	1590000430	S.TRANSISTOR	DTC144EU T107
D1	1750000260	S.DIODE	1SS352 (TPH3)
D2	1750000260	S.DIODE	1SS352 (TPH3)
D3	1750000260	S.DIODE	1SS352 (TPH3)
D4	1750000260	S.DIODE	1SS352 (TPH3)
D5	1750000260	S.DIODE	1SS352 (TPH3)
D6	1750000260	S.DIODE	1SS352 (TPH3)
D7	1750000260	S.DIODE	1SS352 (TPH3)
D8	1750000260	S.DIODE	1SS352 (TPH3)
D9	1750000260	S.DIODE	1SS352 (TPH3)
D10	1750000260	S.DIODE	1SS352 (TPH3)
D12	1750000260	S.DIODE	1SS352 (TPH3) (EUR)
D13	1750000260	S.DIODE	1SS352 (TPH3) (AUS, SEA)
D14	1750000260	S.DIODE	1SS352 (TPH3) (EUR, USA, SEA)
D15	1710000600	DIODE	1SS254 (USA, SEA)
D16	1710000600	DIODE	1SS254 (USA, SEA)
D17	1710000600	DIODE	1SS254 (USA, SEA)
D18	1710000600	DIODE	1SS254 (USA, SEA)
D20	1710000600	DIODE	1SS254 (EUR, AUS, SEA)

S.=Surface mount

[CONTROL UNIT]

REF. NO.	ORDER NO.	DESCRIPTION	
D21	1710000600	DIODE	1SS254 (EUR, AUS)
D22	1750000280	S.DIODE	1SS352 (TPH3)
D23	1750000280	S.DIODE	1SS352 (TPH3)
D24	1750000280	S.DIODE	1SS352 (TPH3)
D25	1750000270	S.DIODE	1SS301 (TE85R)
D28	1750000280	S.DIODE	1SS352 (TPH3)
D27	1750000280	S.DIODE	1SS352 (TPH3)
D28	1750000270	S.DIODE	1SS301 (TE85R)
D29	1750000280	S.DIODE	1SS352 (TPH3)
D32	1730002280	S.ZENER	MA8091-M (TX)
D33	1750000280	S.DIODE	1SS352 (TPH3)
X1	6050008160	S.XTAL	CR-410 MA-416 9.8304 MHz
X2	6080000530	S.CERAMIC	CSB800J200T
L9	6200001270	S.COIL	MLF2012A 2R2M-T
L10	6200001270	S.COIL	MLF2012A 2R2M-T
L11	6200001270	S.COIL	MLF2012A 2R2M-T
L12	6200001270	S.COIL	MLF2012A 2R2M-T
R1	7030001170	S.RESISTOR	MCR50JZHJ 220 Ω (221)
R2	7030003490	S.RESISTOR	ERJ3GEYJ 272 V (2.7 kΩ)
R3	7030003440	S.RESISTOR	ERJ3GEYJ 102 V (1 kΩ)
R4	7030003600	S.RESISTOR	ERJ3GEYJ 223 V (22 kΩ)
R5	7030003320	S.RESISTOR	ERJ3GEYJ 101 V (100 Ω)
R6	7030003680	S.RESISTOR	ERJ3GEYJ 104 V (100 kΩ)
R7	7030003680	S.RESISTOR	ERJ3GEYJ 104 V (100 kΩ)
R12	7030003650	S.RESISTOR	ERJ3GEYJ 563 V (56 kΩ)
R13	7030003680	S.RESISTOR	ERJ3GEYJ 104 V (100 kΩ)
R14	7030003800	S.RESISTOR	ERJ3GEYJ 105 V (1 MΩ)
R15	7030003640	S.RESISTOR	ERJ3GEYJ 473 V (47 kΩ)
R16	7030003640	S.RESISTOR	ERJ3GEYJ 473 V (47 kΩ)
R17	7030003640	S.RESISTOR	ERJ3GEYJ 473 V (47 kΩ)
R18	7030003640	S.RESISTOR	ERJ3GEYJ 473 V (47 kΩ)
R19	7030003640	S.RESISTOR	ERJ3GEYJ 473 V (47 kΩ)
R20	7030003640	S.RESISTOR	ERJ3GEYJ 473 V (47 kΩ)
R21	7030003640	S.RESISTOR	ERJ3GEYJ 473 V (47 kΩ)
R22	7030003640	S.RESISTOR	ERJ3GEYJ 473 V (47 kΩ)
R23	7030003640	S.RESISTOR	ERJ3GEYJ 473 V (47 kΩ)
R24	7030003640	S.RESISTOR	ERJ3GEYJ 473 V (47 kΩ)
R25	7030003640	S.RESISTOR	ERJ3GEYJ 473 V (47 kΩ)
R26	7030003640	S.RESISTOR	ERJ3GEYJ 473 V (47 kΩ)
R27	7030003640	S.RESISTOR	ERJ3GEYJ 473 V (47 kΩ)
R28	7030003640	S.RESISTOR	ERJ3GEYJ 473 V (47 kΩ)
R29	7030003640	S.RESISTOR	ERJ3GEYJ 473 V (47 kΩ)
R30	7030003640	S.RESISTOR	ERJ3GEYJ 473 V (47 kΩ)
R31	7030003640	S.RESISTOR	ERJ3GEYJ 473 V (47 kΩ)
R32	7030003640	S.RESISTOR	ERJ3GEYJ 473 V (47 kΩ)
R33	7030003640	S.RESISTOR	ERJ3GEYJ 473 V (47 kΩ)
R34	7030003680	S.RESISTOR	ERJ3GEYJ 104 V (100 kΩ)
R37	7030003640	S.RESISTOR	ERJ3GEYJ 473 V (47 kΩ)
R38	7030003440	S.RESISTOR	ERJ3GEYJ 102 V (1 kΩ)
R39	7030003390	S.RESISTOR	ERJ3GEYJ 391 V (390 Ω)
R40	7030001040	S.RESISTOR	MCR50JZHJ 18 Ω (180)
R41	7030000380	S.RESISTOR	MCR10EZJH 1 kΩ (102)
R42	7030001220	S.RESISTOR	MCR50JZHJ 560 Ω (561)
R43	7030003560	S.RESISTOR	ERJ3GEYJ 103 V (10 kΩ)
R44	7030003680	S.RESISTOR	ERJ3GEYJ 104 V (100 kΩ)
R45	7030003520	S.RESISTOR	ERJ3GEYJ 472 V (4.7 kΩ)
R46	7030003560	S.RESISTOR	ERJ3GEYJ 103 V (10 kΩ)
R47	7030003640	S.RESISTOR	ERJ3GEYJ 473 V (47 kΩ)
R48	7030003540	S.RESISTOR	ERJ3GEYJ 682 V (6.8 kΩ)
R49	7030003640	S.RESISTOR	ERJ3GEYJ 473 V (47 kΩ)
R50	7030003560	S.RESISTOR	ERJ3GEYJ 103 V (10 kΩ)
R51	7030003600	S.RESISTOR	ERJ3GEYJ 223 V (22 kΩ)
R52	7030003440	S.RESISTOR	ERJ3GEYJ 102 V (1 kΩ)
R58	7030003640	S.RESISTOR	ERJ3GEYJ 473 V (47 kΩ)
R59	7030003560	S.RESISTOR	ERJ3GEYJ 103 V (10 kΩ)
R60	7030003800	S.RESISTOR	ERJ3GEYJ 105 V (1 MΩ)
R69	7030003800	S.RESISTOR	ERJ3GEYJ 105 V (1 MΩ)
R71	7030003360	S.RESISTOR	ERJ3GEYJ 221 V (220 Ω)
R72	7030003640	S.RESISTOR	ERJ3GEYJ 225 V (2.2 MΩ)
R73	7030003560	S.RESISTOR	ERJ3GEYJ 103 V (10 kΩ)

[CONTROL UNIT]

REF. NO.	ORDER NO.	DESCRIPTION	
R75	7030003430	S.RESISTOR	ERJ3GEYJ 821 V (820 Ω)
R76	7030003680	S.RESISTOR	ERJ3GEYJ 104 V (100 kΩ)
R77	7030003690	S.RESISTOR	ERJ3GEYJ 124 V (120 kΩ)
R78	7030003830	S.RESISTOR	ERJ3GEYJ 185 V (1.8 MΩ)
R79	7030004790	S.RESISTOR	ERJ3GEYF 243 V (24 kΩ)
R80	7030003680	S.RESISTOR	ERJ3GEYJ 104 V (100 kΩ)
R81	7030003690	S.RESISTOR	ERJ3GEYJ 124 V (120 kΩ)
R82	7030003200	S.RESISTOR	ERJ3GEYJ 100 V (10 Ω)
R83	7030004790	S.RESISTOR	ERJ3GEYF 243 V (24 kΩ)
R84	7030003620	S.RESISTOR	ERJ3GEYJ 333 V (33 kΩ)
R108	7030003640	S.RESISTOR	ERJ3GEYJ 473 V (47 kΩ)
R109	7030003680	S.RESISTOR	ERJ3GEYJ 104 V (100 kΩ)
R110	7030003560	S.RESISTOR	ERJ3GEYJ 103 V (10 kΩ)
R111	7030003680	S.RESISTOR	ERJ3GEYJ 104 V (100 kΩ)
R114	7030003560	S.RESISTOR	ERJ3GEYJ 103 V (10 kΩ)
R115	7030003600	S.RESISTOR	ERJ3GEYJ 223 V (22 kΩ)
R116	7030003750	S.RESISTOR	ERJ3GEYJ 394 V (390 kΩ)
R117	7030003690	S.RESISTOR	ERJ3GEYJ 124 V (120 kΩ)
R127	7030003220	S.RESISTOR	ERJ3GEYJ 150 V (15 Ω)
R128	7030003640	S.RESISTOR	ERJ3GEYJ 473 V (47 kΩ)
R129	7030003640	S.RESISTOR	ERJ3GEYJ 473 V (47 kΩ)
R130	7030003640	S.RESISTOR	ERJ3GEYJ 473 V (47 kΩ)
R131	7030003560	S.RESISTOR	ERJ3GEYJ 103 V (10 kΩ)
R135	7030003440	S.RESISTOR	ERJ3GEYJ 102 V (1 kΩ)
R136	7030003480	S.RESISTOR	ERJ3GEYJ 222 V (2.2 kΩ)
R137	7030003560	S.RESISTOR	ERJ3GEYJ 103 V (10 kΩ)
R138	7030003560	S.RESISTOR	ERJ3GEYJ 103 V (10 kΩ)
R139	7030003480	S.RESISTOR	ERJ3GEYJ 222 V (2.2 kΩ)
R140	7030003440	S.RESISTOR	ERJ3GEYJ 102 V (1 kΩ)
R141	7030003480	S.RESISTOR	ERJ3GEYJ 222 V (2.2 kΩ)
R142	7030000140	S.RESISTOR	MCR10EZJH 10 Ω (100)
R148	7030003670	S.RESISTOR	ERJ3GEYJ 823 V (82 kΩ)
R149	7030003320	S.RESISTOR	ERJ3GEYJ 101 V (100 Ω)
R150	7030003320	S.RESISTOR	ERJ3GEYJ 101 V (100 Ω)
R151	7030003680	S.RESISTOR	ERJ3GEYJ 104 V (100 kΩ)
C1	4030006850	S.CERAMIC	C1808 JB 1H 471K-T-A
C2	4030006830	S.CERAMIC	C1808 JF 1C 104Z-T-A
C3	4030006890	S.CERAMIC	C1808 JF 1H 103Z-T-A
C5	4030006880	S.CERAMIC	C2012 JF 1C 105Z-T-A
C6	4030007060	S.CERAMIC	C1808 CH 1H 270J-T-A
C7	4030007060	S.CERAMIC	C1808 CH 1H 270J-T-A
C8	4030006890	S.CERAMIC	C1808 JF 1H 103Z-T-A
C9	4510004540	S.ELECTRO-LITIC	ECEV0JA470P
C10	4030006890	S.CERAMIC	C1808 JF 1H 103Z-T-A
C11	4510005430	S.ELECTRO-LITIC	ECEV0JA220R
C12	4030006890	S.CERAMIC	C1808 JF 1H 103Z-T-A
C13	4510005310	S.ELECTRO-LITIC	ECEV1CA220R
C14	4030006890	S.CERAMIC	C1808 JF 1H 103Z-T-A
C15	4030006890	S.CERAMIC	C1808 JF 1H 103Z-T-A
C16	4510004630	S.ELECTRO-LITIC	ECEV1CA100R
C17	4030006890	S.CERAMIC	C1808 JF 1H 103Z-T-A
C18	4510005310	S.ELECTRO-LITIC	ECEV1CA220R
C19	4030006890	S.CERAMIC	C1808 JF 1H 103Z-T-A
C21	4510004630	S.ELECTRO-LITIC	ECEV1CA100R
C22	4030006860	S.CERAMIC	C1808 JB 1H 102K-T-A
C23	4030006850	S.CERAMIC	C1808 JB 1H 471K-T-A
C24	4030006890	S.CERAMIC	C1808 JF 1H 103Z-T-A
C25	4030006890	S.CERAMIC	C1808 JF 1H 103Z-T-A
C26	4030006890	S.CERAMIC	C1808 JF 1H 103Z-T-A
C27	4030006710	S.CERAMIC	C1808 SL 1H 470J-T-A
C28	4030006890	S.CERAMIC	C1808 JF 1H 103Z-T-A
C29	4030006750	S.CERAMIC	C1808 SL 1H 101J-T-A
C30	4030006750	S.CERAMIC	C1808 SL 1H 101J-T-A
C39	4030006890	S.CERAMIC	C1808 JF 1H 103Z-T-A
C48	4030006470	S.CERAMIC	C2012 JB 1H 153K-T-A
C50	4030005110	S.CERAMIC	C2012 JB 1E 473K-T-A
C51	4030006830	S.CERAMIC	C1808 JF 1C 104Z-T-A
C52	4030006620	S.CERAMIC	C1808 SL 1H 120J-T-A

S.=Surface mount

[CONTROL UNIT]

REF. NO.	ORDER NO.	DESCRIPTION	
C53	4030008630	S.CERAMIC	C1608 JF 1C 104Z-T-A
C54	4030008650	S.CERAMIC	C1608 JB 1H 471K-T-A
C55	4030008650	S.CERAMIC	C1608 JB 1H 471K-T-A
C56	4030008650	S.CERAMIC	C1608 JB 1H 471K-T-A
C57	4030008650	S.CERAMIC	C1608 JB 1H 471K-T-A
C83	4030008630	S.CERAMIC	C1608 JF 1C 104Z-T-A
C84	4030008630	S.CERAMIC	C1608 JF 1C 104Z-T-A
C85	4030008630	S.CERAMIC	C1608 JF 1C 104Z-T-A
C86	4030008630	S.CERAMIC	C1608 JF 1C 104Z-T-A
C87	4030008630	S.CERAMIC	C1608 JF 1C 104Z-T-A
C88	4030008630	S.CERAMIC	C1608 JF 1C 104Z-T-A
C89	4030008660	S.CERAMIC	C1608 JB 1H 102K-T-A
C90	4030006710	S.CERAMIC	C1608 SL 1H 470J-T-A
C91	4030008890	S.CERAMIC	C1608 JF 1H 103Z-T-A
C92	4030008630	S.CERAMIC	C1608 JF 1C 104Z-T-A
C93	4510005300	S.ELECTRO-LITIC	ECEV1AA330P
C96	4510004630	S.ELECTRO-LITIC	ECEV1CA100R
C103	4030008630	S.CERAMIC	C1608 JF 1C 104Z-T-A
C106	4030008890	S.CERAMIC	C1608 JF 1H 103Z-T-A
C111	4550004060	S.TANTALUM	F95 OJ106MSAAQ2
C112	4030009580	S.CERAMIC	C1608 JB 1H 681K-T-A
C113	4030009580	S.CERAMIC	C1608 JB 1H 681K-T-A
C114	4030009580	S.CERAMIC	C1608 JB 1H 681K-T-A
C115	4030009580	S.CERAMIC	C1608 JB 1H 681K-T-A
C116	4030009580	S.CERAMIC	C1608 JB 1H 681K-T-A
C117	4030009580	S.CERAMIC	C1608 JB 1H 681K-T-A
C118	4030009580	S.CERAMIC	C1608 JB 1H 681K-T-A
C119	4030009580	S.CERAMIC	C1608 JB 1H 681K-T-A
C120	4030009580	S.CERAMIC	C1608 JB 1H 681K-T-A
C121	4030009580	S.CERAMIC	C1608 JB 1H 681K-T-A
C122	4030009580	S.CERAMIC	C1608 JB 1H 681K-T-A
C123	4030009580	S.CERAMIC	C1608 JB 1H 681K-T-A
C124	4030009580	S.CERAMIC	C1608 JB 1H 681K-T-A
C125	4030009580	S.CERAMIC	C1608 JB 1H 681K-T-A
BT1	3020000210	LITHIUM	BR2032-1F2
W1	7120000380	JUMPER	JPW 01 R-01
W2	7120000380	JUMPER	JPW 01 R-01
W5	7030003860	S.JUMPER	ERJ3GE JPW V
W6	7030003860	S.JUMPER	ERJ3GE JPW V
W7	7030003860	S.JUMPER	ERJ3GE JPW V
W8	7030003860	S.JUMPER	ERJ3GE JPW V
W10	8900003820	CABLE	OPC-365
W12	7030003860	S.JUMPER	ERJ3GE JPW V
W13	7030003860	S.JUMPER	ERJ3GE JPW V
J1	6510014940	S.CONNECTOR	52207-1890
J2	6510010990	CONNECTOR	PI28B-06M
J3	6450001410	CONNECTOR	HJC0177-013022 Microphone connector
S1	2230000550	SWITCH	SPPH23079A [PWR]
EP1	0910036757	PCB	B 3531G
MP1	8930017741	SHEET	Battery insulating sheet (A)-1
MP2	8930028701	SPONGE	1126 jack sponge-1

[ASW BOARD]

REF. NO.	ORDER NO.	DESCRIPTION	
S1	2210000600	SWITCH	EVQ-T6RF0120B 144 MHz [DIAL], [VOL]
EP1	0910036781	PCB	B 3536A

[BSW BOARD]

REF. NO.	ORDER NO.	DESCRIPTION	
S1	2210000600	SWITCH	EVQ-T6RF0120B 430 (440) MHz [DIAL], [VOL]
EP1	0910036781	PCB	B 3536A

[CSW BOARD]

REF. NO.	ORDER NO.	DESCRIPTION	
S1	2210000600	SWITCH	EVQ-T6RF0120B 1200 MHz [DIAL], [VOL]
EP1	0910036781	PCB	B 3536A

[FRONT PANEL]

REF. NO.	ORDER NO.	DESCRIPTION	
W1	8900005110	CABLE	OPC-498
MP1	8010014471	PANEL	1126 C.T.panel(C)-1 IC- Δ100H window panel
MP3	8010012772	PANEL	1126 C.B.panel-2
MP4	8010012811	PANEL	1126 C.S.panel-1
MP10	8010012780	PANEL	1126 reflector
MP14	8610008100	KNOB	Knob K188
MP17	8610008130	KNOB	Knob K189
MP18	8610008140	KNOB	Knob K189 (A)
MP19	8610008150	KNOB	Knob K189 (B)
MP20	8610008160	KNOB	Knob K189 (C)
MP21	8610008170	KNOB	Knob K189 (D)
MP22	8610008181	KNOB	Knob K190-1
MP23	8610008191	KNOB	Knob N187-1
MP24	8610008200	KNOB	Knob N188
MP25	8930025140	SPONGE	1126 B-sponge
MP26	8930025150	SPONGE	1126 C-sponge
MP27	8810005850	SCREW	PHB0 No. 0 M2 × 6
MP28	8810001580	SCREW	PHPT M2 × 15 black
MP29	8810005850	SCREW	PHB0 No. 0 M2 × 6
MP30	8830000550	SCREW	VR nut (E)
MP31	8310011870	LABEL	Caution sticker 900 EXP
MP32	8930028750	SHEET	1126 mask-A film
MP33	8310031790	LABEL	Indication sticker (G) 70M

S.=Surface mount Screw abbreviation PH: Pan head



## [LOGIC UNIT]

REF. NO.	ORDER NO.	DESCRIPTION	
IC1	1110000960	S.IC	NJM4558M (T1)
IC2	1110000960	S.IC	NJM4558M (T1)
IC3	1130005810	S.IC	BU4094BF-T1
IC4	1130004730	S.IC	BU4068BF-T1
IC5	1130004230	S.IC	LC7366NM
IC6	1130005810	S.IC	BU4094BF-T1
IC7	1180001070	S.IC	TA7805F (TE16L)
IC8	1110000490	IC	AN6541
IC9	1140003740	S.IC	μPD78212GC-517-AB8
IC10	1130005820	S.IC	TC4S584F (TE85R)
IC11	1110001550	S.IC	S-8054ALB-LM-T1
IC12	1130006800	S.IC	TC7W08F (TE12L)
IC13	1130003610	S.IC	TC4SU68F (TE85R)
IC14	1130005820	S.IC	TC4S584F (TE85R)
IC15	1130004200	S.IC	TC4S66F (TE85R)
Q1	1590001390	S.FET	2SJ144-Y (TE85R)
Q2	1530002840	S.TRANSISTOR	2SC4116-Y (TE85R)
Q3	1590001390	S.FET	2SJ144-Y (TE85R)
Q4	1530002840	S.TRANSISTOR	2SC4116-Y (TE85R)
Q5	1590001390	S.FET	2SJ144-Y (TE85R)
Q6	1510000690	S.TRANSISTOR	2SA1734 (TE12R)
Q7	1590000680	S.TRANSISTOR	DTC114EU T107
Q8	1590001000	S.TRANSISTOR	RN2427 (TE85R)
Q9	1590000680	S.TRANSISTOR	DTC114EU T107
Q10	1530002840	S.TRANSISTOR	2SC4116-Y (TE85R)
Q11	1530002840	S.TRANSISTOR	2SC4116-Y (TE85R)
D1	1750000300	S.DIODE	1SS302 (TE85R)
D2	1750000260	S.DIODE	1SS352 (TPH3)
D3	1750000260	S.DIODE	1SS352 (TPH3)
D4	1750000260	S.DIODE	1SS352 (TPH3)
X1	6050006020	XTAL	CR-288
X2	6050008160	S.XTAL	CR-410 MA-416 9.8304 MHz
R2	7030003720	S.RESISTOR	ERJ3GEYJ 224 V (220 kΩ)
R3	7030003940	S.RESISTOR	ERJ3GEYF 104 V (100 kΩ)
R4	7030003840	S.RESISTOR	ERJ3GEYJ 225 V (2.2 MΩ)
R5	7030003940	S.RESISTOR	ERJ3GEYF 104 V (100 kΩ)
R6	7030003530	S.RESISTOR	ERJ3GEYJ 562 V (5.6 kΩ)
R7	7030003840	S.RESISTOR	ERJ3GEYJ 225 V (2.2 MΩ)
R9	7030003720	S.RESISTOR	ERJ3GEYJ 224 V (220 kΩ)
R14	7030003320	S.RESISTOR	ERJ3GEYJ 101 V (100 Ω)
R15	7030003640	S.RESISTOR	ERJ3GEYJ 473 V (47 kΩ)
R16	7030003640	S.RESISTOR	ERJ3GEYJ 473 V (47 kΩ)
R17	7030003570	S.RESISTOR	ERJ3GEYJ 123 V (12 kΩ)
R18	7030003780	S.RESISTOR	ERJ3GEYJ 474 V (470 kΩ)
R19	7030003700	S.RESISTOR	ERJ3GEYJ 154 V (150 kΩ)
R20	7030003710	S.RESISTOR	ERJ3GEYJ 184 V (180 kΩ)
R22	7030003700	S.RESISTOR	ERJ3GEYJ 154 V (150 kΩ)
R23	7030003630	S.RESISTOR	ERJ3GEYJ 393 V (39 kΩ)
R24	7030003780	S.RESISTOR	ERJ3GEYJ 684 V (680 kΩ)
R25	7310003590	S.TRIMMER	EVM-1XSX50 B24 (203)
R26	7030003680	S.RESISTOR	ERJ3GEYJ 104 V (100 kΩ)
R27	7030003320	S.RESISTOR	ERJ3GEYJ 101 V (100 Ω)
R28	7030003840	S.RESISTOR	ERJ3GEYJ 225 V (2.2 MΩ)
R29	7030003680	S.RESISTOR	ERJ3GEYJ 104 V (100 kΩ)
R30	7030003840	S.RESISTOR	ERJ3GEYJ 225 V (2.2 MΩ)
R31	7030003680	S.RESISTOR	ERJ3GEYJ 104 V (100 kΩ)
R32	7030003780	S.RESISTOR	ERJ3GEYJ 474 V (470 kΩ)
R33	7030003560	S.RESISTOR	ERJ3GEYJ 103 V (10 kΩ)
R34	7030003640	S.RESISTOR	ERJ3GEYJ 473 V (47 kΩ)
R35	7030003520	S.RESISTOR	ERJ3GEYJ 472 V (4.7 kΩ)
R36	7030003750	S.RESISTOR	ERJ3GEYJ 394 V (390 kΩ)
R37	7030003710	S.RESISTOR	ERJ3GEYJ 184 V (180 kΩ)
R38	7030003570	S.RESISTOR	ERJ3GEYJ 123 V (12 kΩ)
R39	7030003520	S.RESISTOR	ERJ3GEYJ 472 V (4.7 kΩ)
R40	7030003560	S.RESISTOR	ERJ3GEYJ 103 V (10 kΩ)
R41	7030003760	S.RESISTOR	ERJ3GEYJ 474 V (470 kΩ)
R42	7030003560	S.RESISTOR	ERJ3GEYJ 103 V (10 kΩ)
R43	7030003800	S.RESISTOR	ERJ3GEYJ 105 V (1 MΩ)

## [LOGIC UNIT]

REF. NO.	ORDER NO.	DESCRIPTION	
R44	7030003800	S.RESISTOR	ERJ3GEYJ 105 V (1 MΩ)
R45	7030003560	S.RESISTOR	ERJ3GEYJ 103 V (10 kΩ)
R46	7030003840	S.RESISTOR	ERJ3GEYJ 225 V (2.2 MΩ)
R47	7030003800	S.RESISTOR	ERJ3GEYJ 105 V (1 MΩ)
R48	7030003480	S.RESISTOR	ERJ3GEYJ 222 V (2.2 kΩ)
R49	7030003370	S.RESISTOR	ERJ3GEYJ 271 V (270 Ω)
R50	7030003640	S.RESISTOR	ERJ3GEYJ 473 V (47 kΩ)
R51	7030003440	S.RESISTOR	ERJ3GEYJ 102 V (1 kΩ)
R52	7310003590	S.TRIMMER	EVM-1XSX50 B24 (203)
R53	7030003800	S.RESISTOR	ERJ3GEYJ 105 V (1 MΩ)
R54	7030003840	S.RESISTOR	ERJ3GEYJ 225 V (2.2 MΩ)
R55	7030003800	S.RESISTOR	ERJ3GEYJ 105 V (1 MΩ)
R56	7030003550	S.RESISTOR	ERJ3GEYJ 822 V (8.2 kΩ)
R57	7030003500	S.RESISTOR	ERJ3GEYJ 332 V (3.3 kΩ)
R58	7030003560	S.RESISTOR	ERJ3GEYJ 103 V (10 kΩ)
R59	7030003800	S.RESISTOR	ERJ3GEYJ 105 V (1 MΩ)
R60	7030000450	S.RESISTOR	MCR10EZJH 3.8 kΩ (392)
R61	7030003440	S.RESISTOR	ERJ3GEYJ 102 V (1 kΩ)
R62	7030003560	S.RESISTOR	ERJ3GEYJ 103 V (10 kΩ)
R63	7030003800	S.RESISTOR	ERJ3GEYJ 223 V (22 kΩ)
R64	7030003640	S.RESISTOR	ERJ3GEYJ 473 V (47 kΩ)
R65	7030003680	S.RESISTOR	ERJ3GEYJ 104 V (100 kΩ)
R66	7030003490	S.RESISTOR	ERJ3GEYJ 272 V (2.7 kΩ)
R67	7030003680	S.RESISTOR	ERJ3GEYJ 104 V (100 kΩ)
R68	7030003680	S.RESISTOR	ERJ3GEYJ 104 V (100 kΩ)
R69	7030003480	S.RESISTOR	ERJ3GEYJ 222 V (2.2 kΩ)
R70	7030003800	S.RESISTOR	ERJ3GEYJ 223 V (22 kΩ)
R71	7030003560	S.RESISTOR	ERJ3GEYJ 103 V (10 kΩ)
R72	7030003680	S.RESISTOR	ERJ3GEYJ 104 V (100 kΩ)
R73	7030003640	S.RESISTOR	ERJ3GEYJ 473 V (47 kΩ)
R75	7030003780	S.RESISTOR	ERJ3GEYJ 474 V (470 kΩ)
R76	7030003760	S.RESISTOR	ERJ3GEYJ 474 V (470 kΩ)
R77	7030003760	S.RESISTOR	ERJ3GEYJ 474 V (470 kΩ)
R78	7030003760	S.RESISTOR	ERJ3GEYJ 474 V (470 kΩ)
R79	7030003760	S.RESISTOR	ERJ3GEYJ 474 V (470 kΩ)
R80	7030003760	S.RESISTOR	ERJ3GEYJ 474 V (470 kΩ)
R81	7030003780	S.RESISTOR	ERJ3GEYJ 474 V (470 kΩ)
R82	7030003800	S.RESISTOR	ERJ3GEYJ 105 V (1 MΩ)
R83	7030003540	S.RESISTOR	ERJ3GEYJ 682 V (6.8 kΩ)
R84	7030003540	S.RESISTOR	ERJ3GEYJ 682 V (6.8 kΩ)
R85	7030003540	S.RESISTOR	ERJ3GEYJ 682 V (6.8 kΩ)
R86	7030003540	S.RESISTOR	ERJ3GEYJ 682 V (6.8 kΩ)
R87	7030003550	S.RESISTOR	ERJ3GEYJ 822 V (8.2 kΩ)
R88	7030003640	S.RESISTOR	ERJ3GEYJ 473 V (47 kΩ)
R89	7030003630	S.RESISTOR	ERJ3GEYJ 393 V (39 kΩ)
R90	7030003650	S.RESISTOR	ERJ3GEYJ 583 V (58 kΩ)
R91	7030003560	S.RESISTOR	ERJ3GEYJ 103 V (10 kΩ)
R92	7030003530	S.RESISTOR	ERJ3GEYJ 562 V (5.6 kΩ)
R93	7030003200	S.RESISTOR	ERJ3GEYJ 100 V (10 Ω)
R94	7030003440	S.RESISTOR	ERJ3GEYJ 102 V (1 kΩ)
R95	7030003440	S.RESISTOR	ERJ3GEYJ 102 V (1 kΩ)
R96	7030003440	S.RESISTOR	ERJ3GEYJ 102 V (1 kΩ)
R97	7030003440	S.RESISTOR	ERJ3GEYJ 102 V (1 kΩ)
R98	7030003680	S.RESISTOR	ERJ3GEYJ 104 V (100 kΩ)
R99	7030003680	S.RESISTOR	ERJ3GEYJ 104 V (100 kΩ)
R100	7030003680	S.RESISTOR	ERJ3GEYJ 104 V (100 kΩ)
R101	7030003680	S.RESISTOR	ERJ3GEYJ 104 V (100 kΩ)
R102	7030003680	S.RESISTOR	ERJ3GEYJ 104 V (100 kΩ)
R103	7030003680	S.RESISTOR	ERJ3GEYJ 104 V (100 kΩ)
R104	7030003640	S.RESISTOR	ERJ3GEYJ 473 V (47 kΩ)
R105	7030003440	S.RESISTOR	ERJ3GEYJ 102 V (1 kΩ)
R106	7030003200	S.RESISTOR	ERJ3GEYJ 100 V (10 Ω)
R107	7030003640	S.RESISTOR	ERJ3GEYJ 473 V (47 kΩ)
R108	7030003640	S.RESISTOR	ERJ3GEYJ 473 V (47 kΩ)
R109	7030003640	S.RESISTOR	ERJ3GEYJ 473 V (47 kΩ)
R110	7030003320	S.RESISTOR	ERJ3GEYJ 101 V (100 Ω)
R111	7030003680	S.RESISTOR	ERJ3GEYJ 104 V (100 kΩ)
R112	7030003760	S.RESISTOR	ERJ3GEYJ 474 V (470 kΩ)
R113	7030003760	S.RESISTOR	ERJ3GEYJ 474 V (470 kΩ)
R114	7030003760	S.RESISTOR	ERJ3GEYJ 474 V (470 kΩ)
R115	7030003760	S.RESISTOR	ERJ3GEYJ 474 V (470 kΩ)
R116	7030003760	S.RESISTOR	ERJ3GEYJ 474 V (470 kΩ)
R117	7030003760	S.RESISTOR	ERJ3GEYJ 474 V (470 kΩ)
R118	7030003760	S.RESISTOR	ERJ3GEYJ 474 V (470 kΩ)
R119	7030003760	S.RESISTOR	ERJ3GEYJ 474 V (470 kΩ)

S.=Surface mount

## [LOGIC UNIT]

REF. NO.	ORDER NO.	DESCRIPTION
C1	4030006850	S.CERAMIC C1808 JB 1H 471K-T-A
C2	4030006850	S.CERAMIC C1808 JB 1H 471K-T-A
C3	4030006850	S.CERAMIC C1808 JB 1H 471K-T-A
C4	4030006710	S.CERAMIC C1808 SL 1H 470J-T-A
C5	4030006710	S.CERAMIC C1808 SL 1H 470J-T-A
C6	4030006890	S.CERAMIC C1808 JF 1H 103Z-T-A
C9	4550004130	S.TANTALUM F95 1C335MSAAQ2
C12	4510004640	S.ELECTRO-LITIC ECEV1CA470P
C13	4030006890	S.CERAMIC C1808 JF 1H 103Z-T-A
C14	4030006750	S.CERAMIC C1808 SL 1H 101J-T-A
C15	4030006760	S.CERAMIC C1808 SL 1H 121J-T-A
C17	4030006900	S.CERAMIC C1808 JB 1E 103K-T-A
C18	4030006870	S.CERAMIC C1808 JB 1H 222K-T-A
C19	4030008760	S.CERAMIC C2012 X7R 1C 104K-T-A
C20	4030008680	S.CERAMIC C2012 JF 1C 105Z-T-A
C21	4030005110	S.CERAMIC C2012 JB 1E 473K-T-A
C22	4030005110	S.CERAMIC C2012 JB 1E 473K-T-A
C23	4030006870	S.CERAMIC C1808 JB 1H 222K-T-A
C24	4550004130	S.TANTALUM F95 1C335MSAAQ2
C25	4030008630	S.CERAMIC C1808 JF 1C 104Z-T-A
C26	4030008880	S.CERAMIC C1808 JB 1C 223K-T-A
C27	4030008760	S.CERAMIC C2012 X7R 1C 104K-T-A
C28	4030008860	S.CERAMIC C1808 JB 1H 102K-T-A
C29	4030008860	S.CERAMIC C1808 JB 1H 102K-T-A
C30	4030008760	S.CERAMIC C2012 X7R 1C 104K-T-A
C31	4030008760	S.CERAMIC C2012 X7R 1C 104K-T-A
C32	4030008680	S.CERAMIC C2012 JF 1C 105Z-T-A
C33	4030008630	S.CERAMIC C1808 JF 1C 104Z-T-A
C35	4030008630	S.CERAMIC C1808 JF 1C 104Z-T-A
C36	4030008760	S.CERAMIC C2012 X7R 1C 104K-T-A
C37	4030008630	S.CERAMIC C1808 JF 1C 104Z-T-A
C39	4030008630	S.CERAMIC C1808 JF 1C 104Z-T-A
C40	4030008890	S.CERAMIC C1808 JF 1H 103Z-T-A
C41	4030008890	S.CERAMIC C1808 JF 1H 103Z-T-A
C42	4030008760	S.CERAMIC C2012 X7R 1C 104K-T-A
C43	4030008890	S.CERAMIC C1808 JF 1H 103Z-T-A
C44	4030008760	S.CERAMIC C2012 X7R 1C 104K-T-A
C45	4030006690	S.CERAMIC C1808 SL 1H 330J-T-A
C46	4030008700	S.CERAMIC C1808 SL 1H 390J-T-A
C47	4030008890	S.CERAMIC C1808 JF 1H 103Z-T-A
C48	4510005320	S.ELECTRO-LITIC ECEV0JA101SP
C49	4030006900	S.CERAMIC C1808 JB 1E 103K-T-A
C50	4510004640	S.ELECTRO-LITIC ECEV1CA470P
C51	4030006900	S.CERAMIC C1808 JB 1E 103K-T-A
C52	4510003890	ELECTROLITIC 18 MV 10 HW
C53	4510004640	S.ELECTRO-LITIC ECEV1CA470P
C54	4030008680	S.CERAMIC C1808 JB 1H 102K-T-A
C55	4510004640	S.ELECTRO-LITIC ECEV1CA470P
C56	4030006900	S.CERAMIC C1808 JB 1E 103K-T-A
C57	4510004640	S.ELECTRO-LITIC ECEV1CA470P
C58	4030006900	S.CERAMIC C1808 JB 1E 103K-T-A
C59	4030006710	S.CERAMIC C1808 SL 1H 470J-T-A
C60	4030006710	S.CERAMIC C1808 SL 1H 470J-T-A
C62	4030006610	S.CERAMIC C1808 SL 1H 100D-T-A
C63	4030006710	S.CERAMIC C1808 SL 1H 470J-T-A
C64	4030006610	S.CERAMIC C1808 SL 1H 100D-T-A
C65	4030006610	S.CERAMIC C1808 SL 1H 100D-T-A
C66	4030008760	S.CERAMIC C2012 X7R 1C 104K-T-A
C67	4030008760	S.CERAMIC C2012 X7R 1C 104K-T-A
C69	4030006710	S.CERAMIC C1808 SL 1H 470J-T-A
C70	4030006710	S.CERAMIC C1808 SL 1H 470J-T-A
C71	4030006710	S.CERAMIC C1808 SL 1H 470J-T-A
C74	4030006610	S.CERAMIC C1808 SL 1H 100D-T-A
C75	4030006610	S.CERAMIC C1808 SL 1H 100D-T-A
C77	4030006610	S.CERAMIC C1808 SL 1H 100D-T-A
C78	4030006710	S.CERAMIC C1808 SL 1H 470J-T-A
C80	4030006710	S.CERAMIC C1808 SL 1H 470J-T-A
C81	4030006710	S.CERAMIC C1808 SL 1H 470J-T-A
C82	4030006710	S.CERAMIC C1808 SL 1H 470J-T-A
C83	4030006710	S.CERAMIC C1808 SL 1H 470J-T-A

## [LOGIC UNIT]

REF. NO.	ORDER NO.	DESCRIPTION
C87	4030006610	S.CERAMIC C1808 SL 1H 100D-T-A
C88	4030006610	S.CERAMIC C1808 SL 1H 100D-T-A
C89	4030006610	S.CERAMIC C1808 SL 1H 100D-T-A
C90	4030006610	S.CERAMIC C1808 SL 1H 100D-T-A
C91	4030006610	S.CERAMIC C1808 SL 1H 100D-T-A
C92	4030007060	S.CERAMIC C1808 CH 1H 270J-T-A
C93	4030007060	S.CERAMIC C1808 CH 1H 270J-T-A
C94	4030006890	S.CERAMIC C1808 JF 1H 103Z-T-A
C95	4030006880	S.CERAMIC C2012 JF 1C 105Z-T-A
C96	4030006880	S.CERAMIC C1808 JF 1H 103Z-T-A
C97	4030006890	S.CERAMIC C1808 JF 1H 103Z-T-A
C98	4510005740	S.ELECTRO-LITIC ECEV1HAR22R
C99	4030006710	S.CERAMIC C1808 SL 1H 470J-T-A
C100	4030006710	S.CERAMIC C1808 SL 1H 470J-T-A
C101	4030006710	S.CERAMIC C1808 SL 1H 470J-T-A
C102	4030006710	S.CERAMIC C1808 SL 1H 470J-T-A
C103	4030006710	S.CERAMIC C1808 SL 1H 470J-T-A
C104	4030006710	S.CERAMIC C1808 SL 1H 470J-T-A
C105	4030006710	S.CERAMIC C1808 SL 1H 470J-T-A
C106	4030006860	S.CERAMIC C1808 JB 1H 102K-T-A
C107	4030006860	S.CERAMIC C1808 JB 1H 102K-T-A
C108	4030006860	S.CERAMIC C1808 JB 1H 102K-T-A
C109	4030006860	S.CERAMIC C1808 JB 1H 102K-T-A
C110	4030006610	S.CERAMIC C1808 SL 1H 100D-T-A
C111	4030006610	S.CERAMIC C1808 SL 1H 100D-T-A
C112	4030006610	S.CERAMIC C1808 SL 1H 100D-T-A
C113	4030006610	S.CERAMIC C1808 SL 1H 100D-T-A
C114	4030006710	S.CERAMIC C1808 SL 1H 470J-T-A
C115	4030006710	S.CERAMIC C1808 SL 1H 470J-T-A
C116	4030006710	S.CERAMIC C1808 SL 1H 470J-T-A
C117	4030006710	S.CERAMIC C1808 SL 1H 470J-T-A
C118	4030006860	S.CERAMIC C1808 JB 1H 102K-T-A
C119	4030006610	S.CERAMIC C1808 SL 1H 100D-T-A
C120	4030006860	S.CERAMIC C1808 JB 1H 102K-T-A
C121	4030006610	S.CERAMIC C1808 SL 1H 100D-T-A
C122	4030006610	S.CERAMIC C1808 SL 1H 100D-T-A
C123	4030006610	S.CERAMIC C1808 SL 1H 100D-T-A
C124	4030006610	S.CERAMIC C1808 SL 1H 100D-T-A
C125	4030006710	S.CERAMIC C1808 SL 1H 470J-T-A
C126	4030006610	S.CERAMIC C1808 SL 1H 100D-T-A
C127	4030006710	S.CERAMIC C1808 SL 1H 470J-T-A
C128	4030006610	S.CERAMIC C1808 SL 1H 100D-T-A
C129	4030006710	S.CERAMIC C1808 SL 1H 470J-T-A
C130	4030006610	S.CERAMIC C1808 SL 1H 100D-T-A
C131	4030006710	S.CERAMIC C1808 SL 1H 470J-T-A
C132	4030006710	S.CERAMIC C1808 SL 1H 470J-T-A
C133	4030006860	S.CERAMIC C2012 JF 1C 105Z-T-A
C134	4030006860	S.CERAMIC C2012 JF 1C 105Z-T-A
C135	4030006860	S.CERAMIC C2012 JF 1C 105Z-T-A
C136	4030004760	S.CERAMIC C2012 JF 1E 104Z-T-A
C138	4030006900	S.CERAMIC C1808 JB 1E 103K-T-A
C139	4030006900	S.CERAMIC C1808 JB 1E 103K-T-A
C140	4030006900	S.CERAMIC C1808 JB 1E 103K-T-A
C141	4030006870	S.CERAMIC C1808 JB 1H 222K-T-A
C142	4030006900	S.CERAMIC C1808 JB 1E 103K-T-A
C143	4030006710	S.CERAMIC C1808 SL 1H 470J-T-A
C144	4030006520	S.CERAMIC C1808 SL 1H 010C-T-A
C145	4030006890	S.CERAMIC C1808 JF 1H 103Z-T-A
C146	4030006710	S.CERAMIC C1808 SL 1H 470J-T-A
C147	4030006890	S.CERAMIC C1808 JF 1H 103Z-T-A
C148	4550002720	S.TANTALUM TESVD2 0J 476M-12L
W7	7030003860	S.JUMPER ERJ3GE JPW V
W13	7410000760	S.JUMPER EXB-V4V JPWV
W20	7030000010	S.JUMPER MCR10EZHZ JPW (000)
J1	6510007100	CONNECTOR PI28A-06M
J2	6510012690	CONNECTOR 53020-0810
J3	6510014900	S.CONNECTOR 52385-1291
J4	6510014910	S.CONNECTOR 52385-1691
J5	6510013000	CONNECTOR 53131-1427
J6	6510013040	CONNECTOR 53131-2827

S.=Surface mount

[LOGIC UNIT]

REF. NO.	ORDER NO.	DESCRIPTION	
EP1	0910036764	PCB	B 3534D

[AF UNIT]

REF. NO.	ORDER NO.	DESCRIPTION	
R33	7030003730	S.RESISTOR	ERJ3GEYJ 274 V (270 kΩ)
R35	7030003680	S.RESISTOR	ERJ3GEYJ 104 V (100 kΩ)
R51	7030003610	S.RESISTOR	ERJ3GEYJ 273 V (27 kΩ)
R52	7030003560	S.RESISTOR	ERJ3GEYJ 103 V (10 kΩ)
R53	7030003640	S.RESISTOR	ERJ3GEYJ 473 V (47 kΩ)
R57	7030003840	S.RESISTOR	ERJ3GEYJ 225 V (2.2 MΩ)
R58	7030003840	S.RESISTOR	ERJ3GEYJ 225 V (2.2 MΩ)
R59	7030003840	S.RESISTOR	ERJ3GEYJ 225 V (2.2 MΩ)
R60	7030003840	S.RESISTOR	ERJ3GEYJ 225 V (2.2 MΩ)
R61	7030003840	S.RESISTOR	ERJ3GEYJ 225 V (2.2 MΩ)
R62	7030003840	S.RESISTOR	ERJ3GEYJ 225 V (2.2 MΩ)
R63	7030003690	S.RESISTOR	ERJ3GEYJ 124 V (120 kΩ)
R64	7030003690	S.RESISTOR	ERJ3GEYJ 124 V (120 kΩ)
R65	7030003690	S.RESISTOR	ERJ3GEYJ 124 V (120 kΩ)
R66	7030003560	S.RESISTOR	ERJ3GEYJ 103 V (10 kΩ)
R67	7030003560	S.RESISTOR	ERJ3GEYJ 103 V (10 kΩ)
R70	7030003560	S.RESISTOR	ERJ3GEYJ 103 V (10 kΩ)
R72	7030001220	S.RESISTOR	MCR50JZHJ 560 Ω (561)
R73	7030000060	S.RESISTOR	MCR10EZJH 2.2 Ω (2R2)
R74	7030000620	S.RESISTOR	MCR10EZJH 100 kΩ (104)
R75	7030000080	S.RESISTOR	MCR10EZJH 3.3 Ω (3R3)
R76	7030000350	S.RESISTOR	MCR10EZJH 560 Ω (561)
R77	7030000280	S.RESISTOR	MCR10EZJH 150 Ω (151)
R78	7030003360	S.RESISTOR	ERJ3GEYJ 221 V (220 Ω)
R79	7030000980	S.RESISTOR	MCR50JZHJ 5.6 Ω (5R6)
R80	7030003400	S.RESISTOR	ERJ3GEYJ 471 V (470 Ω)
R81	7030003520	S.RESISTOR	ERJ3GEYJ 472 V (4.7 kΩ)
R82	7030003690	S.RESISTOR	ERJ3GEYJ 124 V (120 kΩ)
R83	7030003550	S.RESISTOR	ERJ3GEYJ 822 V (8.2 kΩ)
R85	7030003560	S.RESISTOR	ERJ3GEYJ 103 V (10 kΩ)
R86	7030003450	S.RESISTOR	ERJ3GEYJ 122 V (1.2 kΩ)
R87	7030003560	S.RESISTOR	ERJ3GEYJ 103 V (10 kΩ)
R91	7030003560	S.RESISTOR	ERJ3GEYJ 103 V (10 kΩ)
R92	7030003560	S.RESISTOR	ERJ3GEYJ 103 V (10 kΩ)
R93	7030003560	S.RESISTOR	ERJ3GEYJ 103 V (10 kΩ)
R94	7030003640	S.RESISTOR	ERJ3GEYJ 473 V (47 kΩ)
R95	7030003360	S.RESISTOR	ERJ3GEYJ 221 V (220 Ω)
R96	7030003720	S.RESISTOR	ERJ3GEYJ 224 V (220 kΩ)
R97	7030003730	S.RESISTOR	ERJ3GEYJ 274 V (270 kΩ)
R98	7030003320	S.RESISTOR	ERJ3GEYJ 101 V (100 Ω)
R99	7030001180	S.RESISTOR	MCR50JZHJ 270 Ω (271)
R100	7030000300	S.RESISTOR	MCR10EZJH 220 Ω (221)
R101	7030000300	S.RESISTOR	MCR10EZJH 220 Ω (221)
R102	7030000300	S.RESISTOR	MCR10EZJH 220 Ω (221)
R103	7030000300	S.RESISTOR	MCR10EZJH 220 Ω (221)
R104	7030000300	S.RESISTOR	MCR10EZJH 220 Ω (221)
R105	7030000300	S.RESISTOR	MCR10EZJH 220 Ω (221)
R106	7030003640	S.RESISTOR	ERJ3GEYJ 473 V (47 kΩ)
R107	7030003640	S.RESISTOR	ERJ3GEYJ 473 V (47 kΩ)
R108	7030003640	S.RESISTOR	ERJ3GEYJ 473 V (47 kΩ)
R109	7030003660	S.RESISTOR	ERJ3GEYJ 683 V (68 kΩ)
R110	7030003560	S.RESISTOR	ERJ3GEYJ 103 V (10 kΩ)
R113	7030003720	S.RESISTOR	ERJ3GEYJ 224 V (220 kΩ)
R114	7030003720	S.RESISTOR	ERJ3GEYJ 224 V (220 kΩ)
R115	7030003800	S.RESISTOR	ERJ3GEYJ 105 V (1 MΩ)
R116	7030003500	S.RESISTOR	ERJ3GEYJ 332 V (3.3 kΩ)
R117	7030003660	S.RESISTOR	ERJ3GEYJ 683 V (68 kΩ)
R118	7030003760	S.RESISTOR	ERJ3GEYJ 474 V (470 kΩ)
R119	7030003660	S.RESISTOR	ERJ3GEYJ 683 V (68 kΩ)
R120	7030003760	S.RESISTOR	ERJ3GEYJ 474 V (470 kΩ)
R121	7030003660	S.RESISTOR	ERJ3GEYJ 683 V (68 kΩ)
R122	7030003760	S.RESISTOR	ERJ3GEYJ 474 V (470 kΩ)
C1	4510005370	S.ELECTRO-LITIC	ECEV1AA221P
C2	4030006890	S.CERAMIC	C1608 JF 1H 103Z-T-A
C3	4510004640	S.ELECTRO-LITIC	ECEV1CA470P
C4	4030006890	S.CERAMIC	C1608 JF 1H 103Z-T-A
C5	4030006890	S.CERAMIC	C1608 JF 1H 103Z-T-A
C6	4030008760	S.CERAMIC	C2012 X7R 1C 104K-T-A
C7	4030008760	S.CERAMIC	C2012 X7R 1C 104K-T-A
C8	4030006890	S.CERAMIC	C1608 JF 1H 103Z-T-A
C9	4030008760	S.CERAMIC	C2012 X7R 1C 104K-T-A
C10	4030006890	S.CERAMIC	C1608 JF 1H 103Z-T-A

[AF UNIT]

REF. NO.	ORDER NO.	DESCRIPTION	
IC1	1110000960	S.IC	NJM4558M (T1)
IC2	1130003060	IC	TC9154AP
IC3	1110000960	S.IC	NJM4558M (T1)
IC4	1110000960	S.IC	NJM4558M (T1)
IC5	1130003060	IC	TC9154AP
IC6	1130006770	S.IC	BU4053BF-T1
IC7	1130005810	S.IC	BU4094BF-T1
IC8	1130004200	S.IC	TC4S66F (TE85R)
IC9	1130004200	S.IC	TC4S66F (TE85R)
IC10	1130004730	S.IC	BU4066BF-T1
IC11	1130005810	S.IC	BU4094BF-T1
IC12	1110000890	IC	μPC1241H
IC13	1110001700	S.IC	TL499ACPS
IC15	1130003710	S.IC	TC4S71F (TE85R)
IC16	1130004200	S.IC	TC4S66F (TE85R)
IC17	1110000960	S.IC	NJM4558M (T1)
IC18	1130007040	S.IC	TC7W32F (TE12L)
IC19	1110002400	S.IC	NJM2107F (TE1)
Q1	1590000430	S.TRANSISTOR	DTC144EU T107
Q2	1530003090	S.TRANSISTOR	2SC4213-B (TE85R)
Q3	1530003090	S.TRANSISTOR	2SC4213-B (TE85R)
Q4	1530003090	S.TRANSISTOR	2SC4213-B (TE85R)
Q5	1530003090	S.TRANSISTOR	2SC4213-B (TE85R)
Q9	1530002690	S.TRANSISTOR	2SC4116-GR (TE85R)
Q10	1510000700	S.TRANSISTOR	2SA1736 (TE12R)
Q11	1530002690	S.TRANSISTOR	2SC4116-GR (TE85R)
Q12	1510000700	S.TRANSISTOR	2SA1736 (TE12R)
Q15	1530002690	S.TRANSISTOR	2SC4116-GR (TE85R)
Q16	1510000700	S.TRANSISTOR	2SA1736 (TE12R)
Q18	1530002840	S.TRANSISTOR	2SC4116-Y (TE85R)
Q19	1590001000	S.TRANSISTOR	RN2427 (TE85R)
Q20	1510000700	S.TRANSISTOR	2SA1736 (TE12R)
Q21	1530003100	S.TRANSISTOR	2SC4541 (TE12R)
Q22	1530002850	S.TRANSISTOR	2SC4116-BL (TE85R)
Q23	1540000250	S.TRANSISTOR	2SD999-T2 CK
Q24	1520000620	TRANSISTOR	2SB1135 S
Q25	1590000430	S.TRANSISTOR	DTC144EU T107
D1	1790001000	S.ZENER	MA8062-L (TX)
D5	1790000070	DIODE	1SS237
D6	1750000270	S.DIODE	1SS301 (TE85R)
L1	6180001120	COIL	FL 5H 101K
L2	6180002620	COIL	RCR664D-101K
R1	7030003320	S.RESISTOR	ERJ3GEYJ 101 V (100 Ω)
R2	7030003560	S.RESISTOR	ERJ3GEYJ 103 V (10 kΩ)
R3	7030003560	S.RESISTOR	ERJ3GEYJ 103 V (10 kΩ)
R4	7030003560	S.RESISTOR	ERJ3GEYJ 103 V (10 kΩ)
R5	7030003560	S.RESISTOR	ERJ3GEYJ 103 V (10 kΩ)
R18	7030003620	S.RESISTOR	ERJ3GEYJ 333 V (33 kΩ)
R19	7030003560	S.RESISTOR	ERJ3GEYJ 103 V (10 kΩ)
R21	7030003780	S.RESISTOR	ERJ3GEYJ 474 V (470 kΩ)
R24	7030003620	S.RESISTOR	ERJ3GEYJ 333 V (33 kΩ)
R25	7030003560	S.RESISTOR	ERJ3GEYJ 103 V (10 kΩ)
R26	7030003620	S.RESISTOR	ERJ3GEYJ 333 V (33 kΩ)
R27	7030003560	S.RESISTOR	ERJ3GEYJ 103 V (10 kΩ)
R28	7030003620	S.RESISTOR	ERJ3GEYJ 333 V (33 kΩ)
R29	7030003560	S.RESISTOR	ERJ3GEYJ 103 V (10 kΩ)
R30	7030003730	S.RESISTOR	ERJ3GEYJ 274 V (270 kΩ)
R32	7030003730	S.RESISTOR	ERJ3GEYJ 274 V (270 kΩ)

S.=Surface mount

## [AF UNIT]

REF. NO.	ORDER NO.	DESCRIPTION	
C11	4030008890	S.CERAMIC	C1808 JF 1H 103Z-T-A
C12	4510004840	S.ELECTRO-LITIC	ECEV1CA470P
C13	4030008890	S.CERAMIC	C1808 JF 1H 103Z-T-A
C14	4030008880	S.CERAMIC	C2012 JF 1C 105Z-T-A
C15	4030008880	S.CERAMIC	C2012 JF 1C 105Z-T-A
C16	4030008880	S.CERAMIC	C2012 JF 1C 105Z-T-A
C17	4030008880	S.CERAMIC	C2012 JF 1C 105Z-T-A
C18	4030008880	S.CERAMIC	C2012 JF 1C 105Z-T-A
C19	4030008890	S.CERAMIC	C1808 JF 1H 103Z-T-A
C20	4030008890	S.CERAMIC	C1808 JF 1H 103Z-T-A
C21	4030004750	S.CERAMIC	C2012 JB 1H 103K-T-A
C22	4030008890	S.CERAMIC	C1808 JF 1H 103Z-T-A
C23	4550004270	S.TANTALUM	F95 1C105MQAAQ2
C24	4030008890	S.CERAMIC	C1808 JF 1H 103Z-T-A
C25	4030008780	S.CERAMIC	C2012 X7R 1C 104K-T-A
C26	4550004270	S.TANTALUM	F95 1C105MQAAQ2
C27	4030008780	S.CERAMIC	C2012 X7R 1C 104K-T-A
C28	4030008780	S.CERAMIC	C2012 X7R 1C 104K-T-A
C29	4550004270	S.TANTALUM	F95 1C105MQAAQ2
C30	4550004270	S.TANTALUM	F95 1C105MQAAQ2
C31	4030008830	S.CERAMIC	C1808 JF 1C 104Z-T-A
C32	4030008830	S.CERAMIC	C1808 JF 1C 104Z-T-A
C33	4030008830	S.CERAMIC	C1808 JF 1C 104Z-T-A
C34	4030008830	S.CERAMIC	C1808 JF 1C 104Z-T-A
C37	4030008880	S.CERAMIC	C2012 JF 1C 105Z-T-A
C38	4030008880	S.CERAMIC	C2012 JF 1C 105Z-T-A
C39	4030008880	S.CERAMIC	C2012 JF 1C 105Z-T-A
C40	4030008890	S.CERAMIC	C1808 JF 1H 103Z-T-A
C41	4030008860	S.CERAMIC	C2012 JB 1H 333K-T-A
C42	4030008860	S.CERAMIC	C2012 JB 1H 333K-T-A
C43	4030008860	S.CERAMIC	C2012 JB 1H 333K-T-A
C44	4030008890	S.CERAMIC	C1808 JF 1H 103Z-T-A
C45	4510005300	S.ELECTRO-LITIC	ECEV1AA330P
C46	4510005300	S.ELECTRO-LITIC	ECEV1AA330P
C47	4510005300	S.ELECTRO-LITIC	ECEV1AA330P
C48	4030008880	S.CERAMIC	C1808 JB 1H 102K-T-A
C50	4030008890	S.CERAMIC	C1808 JF 1H 103Z-T-A
C51	4510004590	ELECTROLITIC	16 MV 470 HC
C52	4030008830	S.CERAMIC	C1808 JF 1C 104Z-T-A
C53	4030008880	S.CERAMIC	C1808 JB 1H 102K-T-A
C54	4030008710	S.CERAMIC	C1808 SL 1H 470J-T-A
C55	4510005180	ELECTROLITIC	16 MV 330 HC
C56	4510004840	S.ELECTRO-LITIC	ECEV1CA470P
C57	4030008780	S.CERAMIC	C2012 X7R 1C 104K-T-A
C58	4510005180	ELECTROLITIC	16 MV 330 HC
C59	4510004840	S.ELECTRO-LITIC	ECEV1CA470P
C60	4030008850	S.CERAMIC	C1808 JB 1H 471K-T-A
C61	4550004700	S.TANTALUM	F95 1V474MQAAQ2
C62	4510005380	ELECTROLITIC	25 MV 47 HWS (5X11)
C63	4030008830	S.CERAMIC	C1808 JF 1C 104Z-T-A
C64	4510003980	ELECTROLITIC	10 MV 100 HWS (5X11)
C65	4510005380	ELECTROLITIC	25 MV 47 HWS (5X11)
C66	4510003980	ELECTROLITIC	10 MV 100 HWS (5X11)
C67	4030008880	S.CERAMIC	C1808 JB 1H 102K-T-A
C68	4550004180	S.TANTALUM	F95 1V104MQAAQ2
C69	4510005390	ELECTROLITIC	35 MV 33 HWS (5X11)
C70	4510005390	ELECTROLITIC	35 MV 33 HWS (5X11)
C71	4510005390	ELECTROLITIC	35 MV 33 HWS (5X11)
C72	4030008710	S.CERAMIC	C1808 SL 1H 470J-T-A
C73	4030008710	S.CERAMIC	C1808 SL 1H 470J-T-A
C74	4030008710	S.CERAMIC	C1808 SL 1H 470J-T-A
C75	4030008710	S.CERAMIC	C1808 SL 1H 470J-T-A
C76	4030008710	S.CERAMIC	C1808 SL 1H 470J-T-A
C77	4030008710	S.CERAMIC	C1808 SL 1H 470J-T-A
C78	4030008710	S.CERAMIC	C1808 SL 1H 470J-T-A
C79	4030008710	S.CERAMIC	C1808 SL 1H 470J-T-A
C80	4030008710	S.CERAMIC	C1808 SL 1H 470J-T-A
C81	4030008710	S.CERAMIC	C1808 SL 1H 470J-T-A
C82	4030008710	S.CERAMIC	C1808 SL 1H 470J-T-A
C83	4030008810	S.CERAMIC	C1808 SL 1H 100D-T-A

## [AF UNIT]

REF. NO.	ORDER NO.	DESCRIPTION	
C84	4030008810	S.CERAMIC	C1808 SL 1H 100D-T-A
C85	4030008810	S.CERAMIC	C1808 SL 1H 100D-T-A
C86	4030008810	S.CERAMIC	C1808 SL 1H 100D-T-A
C87	4030008710	S.CERAMIC	C1808 SL 1H 470J-T-A
C88	4030008710	S.CERAMIC	C1808 SL 1H 470J-T-A
C89	4030008710	S.CERAMIC	C1808 SL 1H 470J-T-A
C90	4030008710	S.CERAMIC	C1808 SL 1H 470J-T-A
C91	4030008710	S.CERAMIC	C1808 SL 1H 470J-T-A
C92	4030008810	S.CERAMIC	C1808 SL 1H 100D-T-A
C93	4030008710	S.CERAMIC	C1808 SL 1H 470J-T-A
C94	4030008810	S.CERAMIC	C1808 SL 1H 100D-T-A
C95	4030008810	S.CERAMIC	C1808 SL 1H 100D-T-A
C96	4030008810	S.CERAMIC	C1808 SL 1H 100D-T-A
C97	4030008810	S.CERAMIC	C1808 SL 1H 100D-T-A
C98	4030008710	S.CERAMIC	C1808 SL 1H 470J-T-A
C99	4030008810	S.CERAMIC	C1808 SL 1H 100D-T-A
C100	4030008710	S.CERAMIC	C1808 SL 1H 470J-T-A
C101	4030008810	S.CERAMIC	C1808 SL 1H 100D-T-A
C102	4030008710	S.CERAMIC	C1808 SL 1H 470J-T-A
C103	4030008810	S.CERAMIC	C1808 SL 1H 100D-T-A
C104	4030008710	S.CERAMIC	C1808 SL 1H 470J-T-A
C105	4030008710	S.CERAMIC	C1808 SL 1H 470J-T-A
C107	4030008710	S.CERAMIC	C1808 SL 1H 470J-T-A
C108	4030008710	S.CERAMIC	C1808 SL 1H 470J-T-A
C109	4030008710	S.CERAMIC	C1808 SL 1H 470J-T-A
C110	4030008710	S.CERAMIC	C1808 SL 1H 470J-T-A
C111	4030008710	S.CERAMIC	C1808 SL 1H 470J-T-A
C112	4030008710	S.CERAMIC	C1808 SL 1H 470J-T-A
C113	4030008710	S.CERAMIC	C1808 SL 1H 470J-T-A
C114	4030008710	S.CERAMIC	C1808 SL 1H 470J-T-A
C115	4030008710	S.CERAMIC	C1808 SL 1H 470J-T-A
C116	4030008710	S.CERAMIC	C1808 SL 1H 470J-T-A
C117	4030008810	S.CERAMIC	C1808 SL 1H 100D-T-A
C118	4030008810	S.CERAMIC	C1808 SL 1H 100D-T-A
C119	4030008810	S.CERAMIC	C1808 SL 1H 100D-T-A
C120	4030008810	S.CERAMIC	C1808 SL 1H 100D-T-A
C121	4030008810	S.CERAMIC	C1808 SL 1H 100D-T-A
C122	4030008810	S.CERAMIC	C1808 SL 1H 100D-T-A
C123	4030008710	S.CERAMIC	C1808 SL 1H 470J-T-A
C124	4030008710	S.CERAMIC	C1808 SL 1H 470J-T-A
C126	4030008710	S.CERAMIC	C1808 SL 1H 470J-T-A
C127	4030008710	S.CERAMIC	C1808 SL 1H 470J-T-A
C128	4030008710	S.CERAMIC	C1808 SL 1H 470J-T-A
C129	4030008710	S.CERAMIC	C1808 SL 1H 470J-T-A
C130	4030008710	S.CERAMIC	C1808 SL 1H 470J-T-A
C131	4030008710	S.CERAMIC	C1808 SL 1H 470J-T-A
C132	4030008710	S.CERAMIC	C1808 SL 1H 470J-T-A
C133	4030008710	S.CERAMIC	C1808 SL 1H 470J-T-A
C134	4030008810	S.CERAMIC	C1808 SL 1H 100D-T-A
C135	4030008810	S.CERAMIC	C1808 SL 1H 100D-T-A
C136	4030008810	S.CERAMIC	C1808 SL 1H 100D-T-A
C137	4030008810	S.CERAMIC	C1808 SL 1H 100D-T-A
C138	4030008810	S.CERAMIC	C1808 SL 1H 100D-T-A
C139	4030008810	S.CERAMIC	C1808 SL 1H 100D-T-A
C140	4030008710	S.CERAMIC	C1808 SL 1H 470J-T-A
C141	4030008710	S.CERAMIC	C1808 SL 1H 470J-T-A
C143	4030008710	S.CERAMIC	C1808 SL 1H 470J-T-A
C144	4030008710	S.CERAMIC	C1808 SL 1H 470J-T-A
C145	4030008710	S.CERAMIC	C1808 SL 1H 470J-T-A
C146	4030008710	S.CERAMIC	C1808 SL 1H 470J-T-A
C147	4030008710	S.CERAMIC	C1808 SL 1H 470J-T-A
C148	4030008710	S.CERAMIC	C1808 SL 1H 470J-T-A
C149	4030008710	S.CERAMIC	C1808 SL 1H 470J-T-A
C150	4030008710	S.CERAMIC	C1808 SL 1H 470J-T-A
C151	4030008810	S.CERAMIC	C1808 SL 1H 100D-T-A
C152	4030008810	S.CERAMIC	C1808 SL 1H 100D-T-A
C153	4030008810	S.CERAMIC	C1808 SL 1H 100D-T-A
C154	4030008810	S.CERAMIC	C1808 SL 1H 100D-T-A
C155	4030008810	S.CERAMIC	C1808 SL 1H 100D-T-A
C156	4030008810	S.CERAMIC	C1808 SL 1H 100D-T-A
C157	4510004540	S.ELECTRO-LITIC	ECEV0JA470P
C158	4510005300	S.ELECTRO-LITIC	ECEV1AA330P
C159	4030008890	S.CERAMIC	C1808 JF 1H 103Z-T-A
C161	4030008890	S.CERAMIC	C1808 JF 1H 103Z-T-A

S.=Surface mount

[AF UNIT]

REF. NO.	ORDER NO.	DESCRIPTION	
C162	4030006710	S.CERAMIC	C1608 SL 1H 470J-T-A
C163	4030006710	S.CERAMIC	C1608 SL 1H 470J-T-A
C164	4030006710	S.CERAMIC	C1608 SL 1H 470J-T-A
C165	4030006710	S.CERAMIC	C1608 SL 1H 470J-T-A
C166	4030008680	S.CERAMIC	C2012 JF 1C 105Z-T-A
C167	4030008680	S.CERAMIC	C2012 JF 1C 105Z-T-A
C170	4510004630	S.ELECTRO-LITIC	ECEV1CA100R
C171	4550004230	S.TANTALUM	F95 1A106MTAAQ2
C172	4030008630	S.CERAMIC	C1608 JF 1C 104Z-T-A
C173	4030008630	S.CERAMIC	C1608 JF 1C 104Z-T-A
C174	4030009580	S.CERAMIC	C1608 JB 1H 681K-T-A
C175	4030009580	S.CERAMIC	C1608 JB 1H 681K-T-A
C176	4030009580	S.CERAMIC	C1608 JB 1H 681K-T-A
C177	4030008630	S.CERAMIC	C1608 JF 1C 104Z-T-A
C178	4030008630	S.CERAMIC	C1608 JF 1C 104Z-T-A
C179	4030008630	S.CERAMIC	C1608 JF 1C 104Z-T-A
W1	7120000010	JUMPER	JPW 02A
W2	7030003860	S.JUMPER	ERJ3GE JPW V
W5	7030003860	S.JUMPER	ERJ3GE JPW V
W6	7120000380	JUMPER	JPW 01 R-01
W7	7030000010	S.JUMPER	MCR10EZHZ JPW (000)
W8	7030000010	S.JUMPER	MCR10EZHZ JPW (000)
W9	7030000010	S.JUMPER	MCR10EZHZ JPW (000)
J1	6510015520	CONNECTOR	53254-0210
J2	6510013060	CONNECTOR	52190-1427
J3	6510013100	CONNECTOR	52190-2827
J4	6510014780	CONNECTOR	53244-1017
J5	6510014780	CONNECTOR	53244-1017
J6	6510014780	CONNECTOR	53244-1017
J7	6510014780	CONNECTOR	53244-1017
J8	6510014780	CONNECTOR	53244-1017
J9	6510014780	CONNECTOR	53244-1017
EP1	0910036774	PCB	B 3535D
EP3	6910002160	CASE	BM7 shield case
EP4	6910007640	CASE	Case-VF1-7H
MP1	8410001840	HEATSINK	1126 AF heatsink
MP2	8830000100	SCREW	Nut M 3
MP4	8860000120	SCREW	Ground contact B 4 (M3) AG BS
MP5	8850000570	WASHER	Washer M 3
MP6	8810003170	SCREW	Setscrew A M3 x 8
MP8	8930001160	SPRING	Ground contact FX 22

[TONE UNIT] (USA only)

REF. NO.	ORDER NO.	DESCRIPTION	
IC1	1130003610	S.IC	TC4SU69F (TE85R)
IC2	1130006960	S.IC	FX365ADW
Q1	1530002840	S.TRANSISTOR	2SC4116-Y (TE85R)
D1	1750000260	S.DIODE	1SS352 (TPH3)
X1	6060000480	CERAMIC	CSB1000J221T
R1	7030003800	S.RESISTOR	ERJ3GEYJ 105 V (1 MΩ)
R2	7030003840	S.RESISTOR	ERJ3GEYJ 473 V (47 kΩ)
R3	7030003520	S.RESISTOR	ERJ3GEYJ 472 V (4.7 kΩ)

[TONE UNIT] (USA only)

REF. NO.	ORDER NO.	DESCRIPTION	
R8	7030003480	S.RESISTOR	ERJ3GEYJ 222 V (2.2 kΩ)
R9	7030003800	S.RESISTOR	ERJ3GEYJ 105 V (1 MΩ)
R10	7030003680	S.RESISTOR	ERJ3GEYJ 104 V (100 kΩ)
R11	7030003560	S.RESISTOR	ERJ3GEYJ 103 V (10 kΩ)
R12	7030003840	S.RESISTOR	ERJ3GEYJ 225 V (2.2 MΩ)
R13	7030003740	S.RESISTOR	ERJ3GEYJ 334 V (330 kΩ)
R14	7030003580	S.RESISTOR	ERJ3GEYJ 153 V (15 kΩ)
R15	7310003630	S.TRIMMER	EVM-1XSX50 BQ4 (473)
C1	4030007170	S.CERAMIC	C1608 CH 1H 221J-T-A
C2	4030007170	S.CERAMIC	C1608 CH 1H 221J-T-A
C3	4030006880	S.CERAMIC	C1608 JB 1H 102K-T-
C4	4550004450	S.TANTALUM	F95 0J475MQAAQ2
C5	4030006900	S.CERAMIC	C1608 JB 1E 103K-T-A
C10	4030006880	S.CERAMIC	C1608 JB 1H 102K-T-A
C11	4030006540	S.CERAMIC	C1608 SL 1H 030C-T-
C12	4550004500	S.TANTALUM	F95 1D105MQAAQ2
C13	4550004160	S.TANTALUM	F95 1V104MQAAQ2
C14	4030006880	S.CERAMIC	C1608 JB 1C 223K-T-A
W1	7030003860	S.JUMPER	ERJ3GE JPW V
J1	6510014920	S.CONNECTOR	53268-1691
EP1	0910036101	PCB	B 3537A

[MAIN-A UNIT]

REF. NO.	ORDER NO.	DESCRIPTION	
IC1	1130004200	S.IC	TC4S68F (TE85R)
IC2	1150000760	IC	SC1091
IC3	1110001971	S.IC	μPC1676G-T1
IC4	1130005810	S.IC	BU4094BF-T1
IC5	1130005810	S.IC	BU4094BF-T1
IC8	1110003090	IC	LA4425A
Q1	1530002840	S.TRANSISTOR	2SC4116-Y (TE85R)
Q2	1530002840	S.TRANSISTOR	2SC4116-Y (TE85R)
Q3	1510000780	S.TRANSISTOR	2SA1586-Y (TE85R)
Q4	1560000540	S.FET	2SK880-Y (TE85R)
Q5	1530002840	S.TRANSISTOR	2SC4116-Y (TE85R)
Q6	1530002920	S.TRANSISTOR	2SC4226-T2 R25
Q7	1530002920	S.TRANSISTOR	2SC4226-T2 R25
Q8	1520000810	TRANSISTOR	2SB1266 S
Q9	1530002920	S.TRANSISTOR	2SC4226-T2 R25
Q10	1580000480	S.FET	3SK184-S (TX)
Q11	1560000430	S.TRANSISTOR	DTC144EU T107
Q12	1580000480	S.FET	3SK184-S (TX)
Q13	1580000480	S.FET	3SK184-S (TX)
Q14	1530002920	S.TRANSISTOR	2SC4226-T2 R25
Q15	1590000430	S.TRANSISTOR	DTC144EU T107
Q16	1580000480	S.FET	3SK184-S (TX)
Q17	1590000430	S.TRANSISTOR	DTC144EU T107
Q18	1590000430	S.TRANSISTOR	DTC144EU T107
Q19	1530002840	S.TRANSISTOR	2SC4116-Y (TE85R)
Q20	1510000690	S.TRANSISTOR	2SA1734 (TE12R)
Q21	1590000430	S.TRANSISTOR	DTC144EU T107
Q22	1590001040	S.TRANSISTOR	DTA113ZU T107
Q23	1590000430	S.TRANSISTOR	DTC144EU T107
Q24	1590001040	S.TRANSISTOR	DTA113ZU T107
Q25	1590000430	S.TRANSISTOR	DTC144EU T107
Q26	1590001040	S.TRANSISTOR	DTA113ZU T107
Q27	1590001540	S.TRANSISTOR	UMD6 TL
Q28	1590000690	S.TRANSISTOR	DTC114EU T107
Q29	1510000690	S.TRANSISTOR	2SA1734 (TE12R)
Q30	1530002840	S.TRANSISTOR	2SC4116-Y (TE85R)

S.=Surface mount

[MAIN-A UNIT]

REF. NO.	ORDER NO.	DESCRIPTION	
Q31	1520000200	S.TRANSISTOR	2SB798-T2 DK
Q32	1590001800	S.TRANSISTOR	UMD3 TL
Q33	1590000680	S.TRANSISTOR	DTC114EU T107
Q34	1590001330	S.TRANSISTOR	DTA114EU T107
Q35	1590000680	S.TRANSISTOR	DTC114EU T107
Q36	1590000680	S.TRANSISTOR	DTC114EU T107
Q37	1560000530	S.FET	2SK880-GR (TE85R)
Q38	1590000430	S.TRANSISTOR	DTC144EU T107
D1	1790000820	S.DIODE	MA132K (TX)
D2	1750000270	S.DIODE	1SS301 (TE85R)
D3	1790000450	S.DIODE	MA882 (TX)
D4	1710000310	DIODE	MI407
D5	1790000980	S.DIODE	MA742 (TX)
D6	1790000980	S.DIODE	MA742 (TX)
D9	1790000820	S.DIODE	MA132K (TX)
D11	1790001000	S.ZENER	MA8062-L (TX)
D12	1790000860	S.DIODE	MA133 (TX)
D13	1790000450	S.DIODE	MA882 (TX)
D14	1720000460	S.VARICAP	1SV167-T1
D15	1720000460	S.VARICAP	1SV167-T1
D16	1720000460	S.VARICAP	1SV167-T1
D17	1790000450	S.DIODE	MA882 (TX)
D18	1710000730	S.DIODE	MI809-T11
D19	1710000730	S.DIODE	MI809-T11
D20	1790001010	S.ZENER	MA8043-L (TX)
D21	1750000270	S.DIODE	1SS301 (TE85R)
D22	1750000270	S.DIODE	1SS301 (TE85R)
D23	1750000260	S.DIODE	1SS352 (TPH3)
D24	1790001000	S.ZENER	MA8062-L (TX)
D25	1750000130	S.DIODE	DA204U T107
FI1	2020000550	CERAMIC	CFUM455E
FI2	2010001490	XTAL	FL-185 UM-1 41.800MHz
X1	6050008220	XTAL	CR-411 UM-1 12.800 MHz
X2	6070000100	DISCRI	CDBM455C18
X3	6050008170	XTAL	CR-405 UM-1 41.345 MHz
L1	6200002000	S.COIL	NL 252018T-3R3J
L2	6200002420	S.COIL	NL 252018T-068J
L3	6200002600	S.COIL	NL 252018T-047J
L4	6200002570	S.COIL	NL 252018T-022K
L5	6200002590	S.COIL	NL 252018T-039J
L6	6200002800	S.COIL	NL 252018T-047J
L7	6170000180	COIL	LW-19
L8	6110001540	COIL	LA-234
L9	6110001550	COIL	LA-235
L10	6110001540	COIL	LA-234
L11	6170000180	COIL	LW-19
L12	6200002040	S.COIL	NL 252018T-101J
L13	6150003970	S.COIL	LS-457
L14	6200002640	S.COIL	NL 252018T-R15J
L15	6150003960	S.COIL	LS-455
L16	6150003960	S.COIL	LS-455
L17	6150003960	S.COIL	LS-455
L18	6200002420	S.COIL	NL 252018T-068J
L19	6200002630	S.COIL	NL 252018T-R10J
L20	6200002630	S.COIL	NL 252018T-R10J
L22	6110001550	COIL	LA-235
L23	6110001550	COIL	LA-235
L24	6200002420	S.COIL	NL 252018T-068J
L25	6200002410	S.COIL	NL 252018T-056J
L26	6200002590	S.COIL	NL 252018T-039J
L27	6200002570	S.COIL	NL 252018T-022K
L28	6200002570	S.COIL	NL 252018T-022K
L29	6200002640	S.COIL	NL 252018T-R15J
L30	6200002650	S.COIL	NL 252018T-R18J
L31	6110001540	COIL	LA-234

[MAIN-A UNIT]

REF. NO.	ORDER NO.	DESCRIPTION	
R1	7030003680	S.RESISTOR	ERJ3GEYJ 104 V (100 kΩ)
R2	7030003720	S.RESISTOR	ERJ3GEYJ 224 V (220 kΩ)
R3	7030003320	S.RESISTOR	ERJ3GEYJ 101 V (100 Ω)
R4	7030003560	S.RESISTOR	ERJ3GEYJ 103 V (10 kΩ)
R5	7030003640	S.RESISTOR	ERJ3GEYJ 473 V (47 kΩ)
R6	7030003440	S.RESISTOR	ERJ3GEYJ 102 V (1 kΩ)
R7	7030003440	S.RESISTOR	ERJ3GEYJ 102 V (1 kΩ)
R8	7030003320	S.RESISTOR	ERJ3GEYJ 101 V (100 Ω)
R9	7030003400	S.RESISTOR	ERJ3GEYJ 471 V (470 Ω)
R10	7030003400	S.RESISTOR	ERJ3GEYJ 471 V (470 Ω)
R11	7030003720	S.RESISTOR	ERJ3GEYJ 224 V (220 kΩ)
R12	7030003680	S.RESISTOR	ERJ3GEYJ 104 V (100 kΩ)
R13	7030003200	S.RESISTOR	ERJ3GEYJ 100 V (10 Ω)
R14	7030003680	S.RESISTOR	ERJ3GEYJ 104 V (100 kΩ)
R15	7030003800	S.RESISTOR	ERJ3GEYJ 105 V (1 MΩ)
R16	7030003540	S.RESISTOR	ERJ3GEYJ 682 V (6.8 kΩ)
R17	7030003520	S.RESISTOR	ERJ3GEYJ 472 V (4.7 kΩ)
R18	7030003630	S.RESISTOR	ERJ3GEYJ 393 V (39 kΩ)
R19	7310003590	S.TRIMMER	EVM-1XSX50 B24 (203)
R20	7030003280	S.RESISTOR	ERJ3GEYJ 470 V (47 Ω)
R21	7030003280	S.RESISTOR	ERJ3GEYJ 470 V (47 Ω)
R22	7030003520	S.RESISTOR	ERJ3GEYJ 472 V (4.7 kΩ)
R23	7030003420	S.RESISTOR	ERJ3GEYJ 681 V (680 Ω)
R24	7030003280	S.RESISTOR	ERJ3GEYJ 470 V (47 Ω)
R25	7030003500	S.RESISTOR	ERJ3GEYJ 332 V (3.3 kΩ)
R26	7030003440	S.RESISTOR	ERJ3GEYJ 102 V (1 kΩ)
R27	7030003280	S.RESISTOR	ERJ3GEYJ 470 V (47 Ω)
R28	7030003420	S.RESISTOR	ERJ3GEYJ 681 V (680 Ω)
R29	7030003520	S.RESISTOR	ERJ3GEYJ 472 V (4.7 kΩ)
R30	7030003480	S.RESISTOR	ERJ3GEYJ 222 V (2.2 kΩ)
R31	7030003280	S.RESISTOR	ERJ3GEYJ 470 V (47 Ω)
R32	7030003370	S.RESISTOR	ERJ3GEYJ 271 V (270 Ω)
R33	7030003230	S.RESISTOR	ERJ3GEYJ 180 V (18 Ω)
R34	7030003370	S.RESISTOR	ERJ3GEYJ 271 V (270 Ω)
R35	7030003440	S.RESISTOR	ERJ3GEYJ 102 V (1 kΩ)
R36	7030003370	S.RESISTOR	ERJ3GEYJ 271 V (270 Ω)
R37	7030003230	S.RESISTOR	ERJ3GEYJ 180 V (18 Ω)
R38	7030003370	S.RESISTOR	ERJ3GEYJ 271 V (270 Ω)
R39	7520000080	S.POSISTOR	PTH9C23 BB 471Q-T
R40	7310003610	S.TRIMMER	EVM-1XSX50 B14 (103)
R41	7030003540	S.RESISTOR	ERJ3GEYJ 682 V (6.8 kΩ)
R42	7030001050	S.RESISTOR	MCR50JZHJ 22 Ω (220)
R44	7030001190	S.RESISTOR	MCR50JZHJ 330 Ω (331)
R45	7030001130	S.RESISTOR	MCR50JZHJ 100 Ω (101)
R46	7030000500	S.RESISTOR	MCR10EZHJ 10 kΩ (103)
R47	7030000600	S.RESISTOR	MCR10EZHJ 68 kΩ (683)
R48	7030000490	S.RESISTOR	MCR10EZHJ 8.2 kΩ (822)
R49	7030000600	S.RESISTOR	MCR10EZHJ 68 kΩ (683)
R51	7310003580	S.TRIMMER	EVM-1XSX50 B15 (104)
R52	7030003560	S.RESISTOR	ERJ3GEYJ 103 V (10 kΩ)
R53	7030003530	S.RESISTOR	ERJ3GEYJ 582 V (5.8 kΩ)
R54	7030003560	S.RESISTOR	ERJ3GEYJ 103 V (10 kΩ)
R55	7030003540	S.RESISTOR	ERJ3GEYJ 682 V (6.8 kΩ)
R57	7030003320	S.RESISTOR	ERJ3GEYJ 101 V (100 Ω)
R58	7030003320	S.RESISTOR	ERJ3GEYJ 101 V (100 Ω)
R59	7030003520	S.RESISTOR	ERJ3GEYJ 472 V (4.7 kΩ)
R61	7030003640	S.RESISTOR	ERJ3GEYJ 473 V (47 kΩ)
R62	7030003320	S.RESISTOR	ERJ3GEYJ 101 V (100 Ω)
R63	7030003420	S.RESISTOR	ERJ3GEYJ 681 V (680 Ω)
R64	7030003440	S.RESISTOR	ERJ3GEYJ 102 V (1 kΩ)
R65	7030003320	S.RESISTOR	ERJ3GEYJ 101 V (100 Ω)
R66	7030003360	S.RESISTOR	ERJ3GEYJ 221 V (220 Ω)
R67	7030003560	S.RESISTOR	ERJ3GEYJ 103 V (10 kΩ)
R68	7030003550	S.RESISTOR	ERJ3GEYJ 822 V (8.2 kΩ)
R69	7030003560	S.RESISTOR	ERJ3GEYJ 103 V (10 kΩ)
R70	7030003680	S.RESISTOR	ERJ3GEYJ 104 V (100 kΩ)
R71	7030003680	S.RESISTOR	ERJ3GEYJ 104 V (100 kΩ)
R72	7030003680	S.RESISTOR	ERJ3GEYJ 104 V (100 kΩ)
R73	7030003280	S.RESISTOR	ERJ3GEYJ 470 V (47 Ω)
R74	7030003200	S.RESISTOR	ERJ3GEYJ 100 V (10 Ω)
R75	7030003310	S.RESISTOR	ERJ3GEYJ 820 V (82 Ω)
R76	7030003640	S.RESISTOR	ERJ3GEYJ 473 V (47 kΩ)
R77	7030003600	S.RESISTOR	ERJ3GEYJ 223 V (22 kΩ)
R79	7030003560	S.RESISTOR	ERJ3GEYJ 103 V (10 kΩ)
R80	7030003560	S.RESISTOR	ERJ3GEYJ 103 V (10 kΩ)
R81	7030003560	S.RESISTOR	ERJ3GEYJ 103 V (10 kΩ)

S.=Surface mount

[MAIN-A UNIT]

REF. NO.	ORDER NO.	DESCRIPTION	
R82	7030003220	S.RESISTOR	ERJ3GEYJ 150 V (15 Ω)
R83	7030003280	S.RESISTOR	ERJ3GEYJ 470 V (47 Ω)
R84	7030003220	S.RESISTOR	ERJ3GEYJ 150 V (15 Ω)
R85	7030003310	S.RESISTOR	ERJ3GEYJ 820 V (82 Ω)
R86	7030003680	S.RESISTOR	ERJ3GEYJ 104 V (100 kΩ)
R87	7030003660	S.RESISTOR	ERJ3GEYJ 683 V (68 kΩ)
R88	7030003570	S.RESISTOR	ERJ3GEYJ 123 V (12 kΩ)
R89	7030003560	S.RESISTOR	ERJ3GEYJ 104 V (100 kΩ)
R90	7030003320	S.RESISTOR	ERJ3GEYJ 101 V (100 Ω)
R91	7030003440	S.RESISTOR	ERJ3GEYJ 102 V (1 kΩ)
R92	7030003650	S.RESISTOR	ERJ3GEYJ 593 V (59 kΩ)
R93	7030003280	S.RESISTOR	ERJ3GEYJ 470 V (47 Ω)
R95	7030000220	S.RESISTOR	MCR10EZHZ 47 Ω (470)
R96	7030000220	S.RESISTOR	MCR10EZHZ 47 Ω (470)
R97	7030003360	S.RESISTOR	ERJ3GEYJ 221 V (220 Ω)
R98	7030003680	S.RESISTOR	ERJ3GEYJ 104 V (100 kΩ)
R99	7030003680	S.RESISTOR	ERJ3GEYJ 104 V (100 kΩ)
R100	7030003430	S.RESISTOR	ERJ3GEYJ 821 V (820 Ω)
R101	7030003470	S.RESISTOR	ERJ3GEYJ 182 V (1.8 kΩ)
R103	7030003680	S.RESISTOR	ERJ3GEYJ 104 V (100 kΩ)
R104	7030003370	S.RESISTOR	ERJ3GEYJ 271 V (270 Ω)
R105	7030003560	S.RESISTOR	ERJ3GEYJ 103 V (10 kΩ)
R108	7030000420	S.RESISTOR	MCR10EZHZ 2.2 kΩ (222)
R109	7030000100	S.RESISTOR	MCR10EZHZ 4.7 Ω (4R7)
R110	7030003440	S.RESISTOR	ERJ3GEYJ 102 V (1 kΩ)
R112	7030003640	S.RESISTOR	ERJ3GEYJ 473 V (47 kΩ)
R113	7030003560	S.RESISTOR	ERJ3GEYJ 103 V (10 kΩ)
R114	7030003220	S.RESISTOR	ERJ3GEYJ 150 V (15 Ω)
R115	7030003680	S.RESISTOR	ERJ3GEYJ 104 V (100 kΩ)
R116	7510000470	S.THERMISTOR	TN20-2V221LT
R117	7310003610	S.TRIMMER	EVM-1XSX50 B14 (103)
R118	7030003630	S.RESISTOR	ERJ3GEYJ 393 V (39 kΩ)
R119	7030003680	S.RESISTOR	ERJ3GEYJ 104 V (100 kΩ)
R120	7030003640	S.RESISTOR	ERJ3GEYJ 473 V (47 kΩ)
R121	7030003610	S.RESISTOR	ERJ3GEYJ 273 V (27 kΩ)
R122	7030003200	S.RESISTOR	ERJ3GEYJ 100 V (10 Ω)
R123	7030001220	S.RESISTOR	MCR50JZHZ 560 Ω (561)
R124	7030003560	S.RESISTOR	ERJ3GEYJ 103 V (10 kΩ)
R125	7030003560	S.RESISTOR	ERJ3GEYJ 103 V (10 kΩ)
R126	7030003520	S.RESISTOR	ERJ3GEYJ 472 V (4.7 kΩ)
R127	7030003380	S.RESISTOR	ERJ3GEYJ 331 V (330 Ω)
R128	7030000140	S.RESISTOR	MCR10EZHZ 10 Ω (100)
R129	7030003480	S.RESISTOR	ERJ3GEYJ 222 V (2.2 kΩ)
C1	4610001820	S.TRIMMER	TZBX4P300BA110T00
C2	4030007100	S.CERAMIC	C1808 CH 1H 560J-T-A
C3	4030006860	S.CERAMIC	C1808 JB 1H 102K-T-A
C4	4030007130	S.CERAMIC	C1808 CH 1H 101J-T-A
C5	4030007110	S.CERAMIC	C1808 CH 1H 680J-T-A
C6	4030006960	S.CERAMIC	C1808 CH 1H 050C-T-A
C7	4030006860	S.CERAMIC	C1808 JB 1H 102K-T-A
C8	4030006860	S.CERAMIC	C1808 JB 1H 102K-T-A
C9	4030006860	S.CERAMIC	C1808 JB 1H 102K-T-A
C10	4030006860	S.CERAMIC	C1808 JB 1H 102K-T-A
C11	4030006860	S.CERAMIC	C1808 JB 1H 102K-T-A
C12	4030006860	S.CERAMIC	C1808 JB 1H 102K-T-A
C13	4030006860	S.CERAMIC	C1808 JB 1H 102K-T-A
C14	4030006860	S.CERAMIC	C1808 JB 1H 102K-T-A
C15	4030006860	S.CERAMIC	C1808 JB 1H 102K-T-A
C16	4030006860	S.CERAMIC	C2012 JF 1C 105Z-T-A
C17	4510004630	S.ELECTRO-LITIC	ECEV1CA100R
C18	4030006860	S.CERAMIC	C1808 JB 1H 102K-T-A
C19	4030006860	S.CERAMIC	C1808 JB 1H 102K-T-A
C20	4030006860	S.CERAMIC	C1808 SL 1H 220J-T-A
C21	4030006860	S.CERAMIC	C1808 JB 1H 102K-T-A
C22	4030006860	S.CERAMIC	C1808 JB 1H 102K-T-A
C23	4030006860	S.CERAMIC	C1808 JB 1H 102K-T-A
C24	4030006570	S.CERAMIC	C1808 SL 1H 080D-T-A
C25	4030006610	S.CERAMIC	C1808 SL 1H 100D-T-A
C26	4030006860	S.CERAMIC	C1808 SL 1H 220J-T-A
C27	4030006620	S.CERAMIC	C1808 SL 1H 120J-T-A
C28	4030006860	S.CERAMIC	C1808 JB 1H 102K-T-A
C29	4030006860	S.CERAMIC	C1808 SL 1H 220J-T-A
C30	4030006540	S.CERAMIC	C1808 SL 1H 030C-T-A

[MAIN-A UNIT]

REF. NO.	ORDER NO.	DESCRIPTION	
C31	4030008440	S.CERAMIC	C1808 SL 1H 1R5C-T-A
C32	4030006510	S.CERAMIC	C1808 SL 1H 0R5C-T-A
C33	4030006860	S.CERAMIC	C1808 JB 1H 102K-T-A
C34	4030006860	S.CERAMIC	C1808 JB 1H 102K-T-A
C35	4030006860	S.CERAMIC	C1808 JB 1H 102K-T-A
C36	4030006860	S.CERAMIC	C1808 JB 1H 102K-T-A
C37	4550004140	S.TANTALUM	F95 1C108MWCAQ2
C38	4030006640	S.CERAMIC	C1808 SL 1H 180J-T-A
C39	4550004140	S.TANTALUM	F95 1C108MWCAQ2
C40	4030006640	S.CERAMIC	C1808 SL 1H 180J-T-A
C41	4550004140	S.TANTALUM	F95 1C108MWCAQ2
C42	4010003890	CERAMIC	DD08 SL 1H 102K 500V
C43	4030006860	S.CERAMIC	C1808 JB 1H 102K-T-A
C44	4550004140	S.TANTALUM	F95 1C108MWCAQ2
C45	4030006860	S.CERAMIC	C1808 JB 1H 102K-T-A
C46	4550004140	S.TANTALUM	F95 1C108MWCAQ2
C47	4010004120	CERAMIC	DD07 B 102K 500V
C49	4010005330	CERAMIC	DD05 SL 360K 500V
C50	4030006860	S.CERAMIC	C1808 JB 1H 102K-T-A
C51	4030006860	S.CERAMIC	C1808 JB 1H 102K-T-A
C52	4010005330	CERAMIC	DD05 SL 360K 500V
C53	4010005330	CERAMIC	DD05 SL 360K 500V
C54	4030006860	S.CERAMIC	C1808 JB 1H 102K-T-A
C55	4030006860	S.CERAMIC	C1808 JB 1H 102K-T-A
C56	4030006860	S.CERAMIC	C1808 JB 1H 102K-T-A
C57	4030006860	S.CERAMIC	C1808 JB 1H 102K-T-A
C58	4510004600	ELECTROLITIC	18 MV 1000 HC
C59	4030004760	S.CERAMIC	C2012 JF 1E 104Z-T-A
C60	4030006830	S.CERAMIC	C1808 JF 1C 104Z-T-A
C61	4030006590	S.CERAMIC	C1808 SL 1H 080D-T-A
C62	4030006590	S.CERAMIC	C1808 SL 1H 080D-T-A
C63	4030006860	S.CERAMIC	C1808 JB 1H 102K-T-A
C64	4030006860	S.CERAMIC	C1808 JB 1H 102K-T-A
C65	4510004630	S.ELECTRO-LITIC	ECEV1CA100R
C66	4030006860	S.CERAMIC	C1808 JB 1H 102K-T-A
C67	4030006860	S.CERAMIC	C1808 JB 1H 102K-T-A
C68	4030006860	S.CERAMIC	C1808 JB 1H 102K-T-A
C69	4030006860	S.CERAMIC	C1808 JB 1H 102K-T-A
C70	4030006540	S.CERAMIC	C1808 SL 1H 030C-T-A
C71	4030006580	S.CERAMIC	C1808 SL 1H 070D-T-A
C72	4030006860	S.CERAMIC	C1808 JB 1H 102K-T-A
C73	4030006860	S.CERAMIC	C1808 JB 1H 102K-T-A
C74	4030006700	S.CERAMIC	C1808 SL 1H 390J-T-A
C75	4030006860	S.CERAMIC	C1808 JB 1H 102K-T-A
C76	4030006860	S.CERAMIC	C1808 JB 1H 102K-T-A
C77	4030006580	S.CERAMIC	C1808 SL 1H 070D-T-A
C78	4030006860	S.CERAMIC	C1808 JB 1H 102K-T-A
C79	4030006560	S.CERAMIC	C1808 SL 1H 050C-T-A
C80	4030006890	S.CERAMIC	C1808 SL 1H 330J-T-A
C82	4030006510	S.CERAMIC	C1808 SL 1H 0R5C-T-A
C83	4030006860	S.CERAMIC	C1808 SL 1H 220J-T-A
C84	4030006530	S.CERAMIC	C1808 SL 1H 020C-T-A
C85	4030006860	S.CERAMIC	C1808 JB 1H 102K-T-A
C86	4030006510	S.CERAMIC	C1808 SL 1H 0R5C-T-A
C87	4030006890	S.CERAMIC	C1808 SL 1H 330J-T-A
C89	4030006860	S.CERAMIC	C1808 JB 1H 102K-T-A
C90	4030006860	S.CERAMIC	C1808 JB 1H 102K-T-A
C91	4030006860	S.CERAMIC	C1808 JB 1H 102K-T-A
C92	4030006610	S.CERAMIC	C1808 SL 1H 100D-T-A
C93	4030006700	S.CERAMIC	C1808 SL 1H 390J-T-A
C94	4030006860	S.CERAMIC	C1808 SL 1H 220J-T-A
C95	4030006860	S.CERAMIC	C1808 JB 1H 102K-T-A
C96	4030006860	S.CERAMIC	C1808 JB 1H 102K-T-A
C97	4030006860	S.CERAMIC	C1808 JB 1H 102K-T-A
C98	4030006860	S.CERAMIC	C1808 JB 1H 102K-T-A
C100	4030006860	S.CERAMIC	C1808 JB 1H 102K-T-A
C101	4030006860	S.CERAMIC	C1808 JB 1H 102K-T-A
C102	4030006860	S.CERAMIC	C1808 JB 1H 102K-T-A
C103	4030006860	S.CERAMIC	C1808 JB 1H 102K-T-A
C104	4030006750	S.CERAMIC	C1808 SL 1H 101J-T-A
C107	4030006520	S.CERAMIC	C1808 SL 1H 010C-T-A
C108	4030006630	S.CERAMIC	C1808 SL 1H 150J-T-A
C110	4030006860	S.CERAMIC	C1808 JB 1H 102K-T-A
C111	4030006670	S.CERAMIC	C1808 SL 1H 20J-T-A
C112	4030006860	S.CERAMIC	C1808 JB 1H 102K-T-A

S.=Surface mount

[MAIN-A UNIT]

REF. NO.	ORDER NO.	DESCRIPTION	
C113	4030006860	S.CERAMIC	C1808 JB 1H 102K-T-A
C114	4030006860	S.CERAMIC	C1808 JB 1H 102K-T-A
C115	4030006860	S.CERAMIC	C1808 JB 1H 102K-T-A
C116	4030006860	S.CERAMIC	C1808 SL 1H 220J-T-A
C117	4030006860	S.CERAMIC	C1808 SL 1H 220J-T-A
C118	4030006750	S.CERAMIC	C1808 SL 1H 101J-T-A
C119	4030006830	S.CERAMIC	C1808 SL 1H 150J-T-A
C120	4030006830	S.CERAMIC	C1808 JF 1C 104Z-T-A
C121	4030006860	S.CERAMIC	C1808 JB 1H 102K-T-A
C122	4030006810	S.CERAMIC	C1808 SL 1H 100D-T-A
C123	4030006580	S.CERAMIC	C1808 SL 1H 050C-T-A
C124	4030006810	S.CERAMIC	C1808 SL 1H 100D-T-A
C125	4030006860	S.CERAMIC	C1808 JB 1H 102K-T-A
C126	4030006860	S.CERAMIC	C1808 JB 1H 102K-T-A
C127	4030006710	S.CERAMIC	C1808 SL 1H 470J-T-A
C128	4030006710	S.CERAMIC	C1808 SL 1H 470J-T-A
C129	4030006710	S.CERAMIC	C1808 SL 1H 470J-T-A
C130	4030006710	S.CERAMIC	C1808 SL 1H 470J-T-A
C131	4030006710	S.CERAMIC	C1808 SL 1H 470J-T-A
C132	4030006710	S.CERAMIC	C1808 SL 1H 470J-T-A
C133	4030006710	S.CERAMIC	C1808 SL 1H 470J-T-A
C134	4030006710	S.CERAMIC	C1808 SL 1H 470J-T-A
C135	4030006710	S.CERAMIC	C1808 SL 1H 470J-T-A
C136	4030006710	S.CERAMIC	C1808 SL 1H 470J-T-A
C137	4030006710	S.CERAMIC	C1808 SL 1H 470J-T-A
C138	4030006710	S.CERAMIC	C1808 SL 1H 470J-T-A
C139	4030006710	S.CERAMIC	C1808 SL 1H 470J-T-A
C140	4030006710	S.CERAMIC	C1808 SL 1H 470J-T-A
C141	4030006710	S.CERAMIC	C1808 SL 1H 470J-T-A
C142	4030006710	S.CERAMIC	C1808 SL 1H 470J-T-A
C143	4030006830	S.CERAMIC	C1808 JF 1C 104Z-T-A
C144	4030006830	S.CERAMIC	C1808 JF 1C 104Z-T-A
C145	4030006830	S.CERAMIC	C1808 JF 1C 104Z-T-A
C146	4030006830	S.CERAMIC	C1808 JF 1C 104Z-T-A
C147	4030006830	S.CERAMIC	C1808 JF 1C 104Z-T-A
C148	4030006830	S.CERAMIC	C1808 JF 1C 104Z-T-A
C149	4030006830	S.CERAMIC	C1808 JF 1C 104Z-T-A
C150	4030006830	S.CERAMIC	C1808 JF 1C 104Z-T-A
C154	4030006860	S.CERAMIC	C1808 JB 1H 102K-T-A
C155	4030006760	S.CERAMIC	C2012 X7R 1C 104K-T-A
C158	4030006830	S.CERAMIC	C1808 JF 1C 104Z-T-A
C159	4510004590	ELECTROLITIC	18 MV 470 HC
C160	4510005370	S.ELECTRO-LITIC	ECEV1AA221P
C161	4030006760	S.CERAMIC	C2012 X7R 1C 104K-T-A
C163	4030006590	S.CERAMIC	C1808 SL 1H 080D-T-A
C165	4030006620	S.CERAMIC	C1808 SL 1H 120J-T-A
C166	4030006540	S.CERAMIC	C1808 SL 1H 030C-T-A
C167	4030006900	S.CERAMIC	C1808 JB 1E 103K-T-A
C168	4550004060	S.TANTALUM	F95 0J106MSAAQ2
C169	4010003890	CERAMIC	DD08 SL 180K 500V
C170	4010003910	CERAMIC	DD08 SL 220K 500V
C171	4550004060	S.TANTALUM	F95 0J106MSAAQ2
C172	4550004330	S.TANTALUM	F95 1C336MGC
W4	7030003860	S.JUMPER	ERJ3GE JPW V
W5	8900002450	CABLE	OPC-223 [144 MHz ANT]
W6	9026801002	WIRE	74/98/015/X98/X98
W8	8900003780	CABLE	OPC-371 [DC13.8V]
J1	6510014710	CONNECTOR	52330-1017
J2	6510014710	CONNECTOR	52330-1017
J3	6510014960	S.CONNECTOR	B2B-ZR-SM3-TF
J4	6510014960	S.CONNECTOR	B2B-ZR-SM3-TF
J5	6450001330	CONNECTOR	HSJ1332-01-020 [144 MHz SP]
J6	6510007080	CONNECTOR	PI28A-02M
EP1	0910036796	PCB	B 3538F

[MAIN-A UNIT]

REF. NO.	ORDER NO.	DESCRIPTION	
MP1	8930005320	SPACER	Filter spacer
MP2	8930005320	SPACER	Filter spacer
MP3	8930005320	SPACER	Filter spacer
MP4	8930024850	TERMINAL	1126 terminal
MP5	8950002960	SHEET	Glass sticker
MP6	8510005350	PLATE	VCO shield (A)
MP7	8930013530	SHEET	Insulating sheet BC
MP8	8930029590	SPRING	1128 spring

[PLL-A BOARD]

REF. NO.	ORDER NO.	DESCRIPTION	
IC1	1130005700	S.IC	M56760FP
IC2	1130004200	S.IC	TC4S66F (TE85R)
Q2	1560000530	S.FET	2SK880-GR (TE85R)
Q3	1530003010	S.TRANSISTOR	2SC4117-GR (TE85R)
Q5	1590001610	S.TRANSISTOR	UMH10 TN
Q6	1560000490	S.FET	2SK508 K52 T2B
Q7	1530002940	S.TRANSISTOR	2SC4228-T2 R44
Q8	1530002940	S.TRANSISTOR	2SC4228-T2 R44
D1	1720000220	S.VARICAP	1SV166-T2B
D2	1720000460	S.VARICAP	1SV167-T1
L1	6200001560	S.COIL	LER 015T R68M
L2	6200001570	S.COIL	LER 015T 1R0M
L3	6200002600	S.COIL	NL 252018T-047J
L4	6200001570	S.COIL	LER 015T 1R0M
L5	6200001570	S.COIL	LER 015T 1R0M
R1	7030003640	S.RESISTOR	ERJ3GEYJ 473 V (47 kΩ)
R2	7030003440	S.RESISTOR	ERJ3GEYJ 102 V (1 kΩ)
R3	7030003510	S.RESISTOR	ERJ3GEYJ 392 V (3.9 kΩ)
R7	7030003540	S.RESISTOR	ERJ3GEYJ 682 V (6.8 kΩ)
R8	7030003410	S.RESISTOR	ERJ3GEYJ 561 V (560 Ω)
R9	7030003480	S.RESISTOR	ERJ3GEYJ 222 V (2.2 kΩ)
R10	7030003320	S.RESISTOR	ERJ3GEYJ 101 V (100 Ω)
R11	7030003360	S.RESISTOR	ERJ3GEYJ 221 V (220 Ω)
R12	7030000460	S.RESISTOR	MCR10EZHZ 4.7 kΩ (472)
R13	7030003480	S.RESISTOR	ERJ3GEYJ 222 V (2.2 kΩ)
R14	7030003520	S.RESISTOR	ERJ3GEYJ 472 V (4.7 kΩ)
R15	7030003450	S.RESISTOR	ERJ3GEYJ 122 V (1.2 kΩ)
R16	7030003520	S.RESISTOR	ERJ3GEYJ 472 V (4.7 kΩ)
R19	7030003280	S.RESISTOR	ERJ3GEYJ 470 V (47 Ω)
R20	7030003280	S.RESISTOR	ERJ3GEYJ 470 V (47 Ω)
R21	7030003400	S.RESISTOR	ERJ3GEYJ 471 V (470 Ω)
R22	7030003500	S.RESISTOR	ERJ3GEYJ 332 V (3.3 kΩ)
R23	7030003410	S.RESISTOR	ERJ3GEYJ 561 V (560 Ω)
R24	7030003380	S.RESISTOR	ERJ3GEYJ 331 V (330 Ω)
R28	7030003500	S.RESISTOR	ERJ3GEYJ 332 V (3.3 kΩ)
R29	7030003410	S.RESISTOR	ERJ3GEYJ 561 V (560 Ω)
R30	7030003380	S.RESISTOR	ERJ3GEYJ 221 V (220 Ω)
R31	7030003560	S.RESISTOR	ERJ3GEYJ 103 V (10 kΩ)
R32	7030003320	S.RESISTOR	ERJ3GEYJ 101 V (100 Ω)
R33	7030003480	S.RESISTOR	ERJ3GEYJ 222 V (2.2 kΩ)
C1	4030006860	S.CERAMIC	C1808 JB 1H 102K-T-A
C3	4030006850	S.CERAMIC	C1808 JB 1H 471K-T-A
C5	4030006760	S.CERAMIC	C2012 X7R 1C 104K-T-A
C6	4030006860	S.CERAMIC	C2012 JF 1C 105Z-T-A
C7	4550002980	S.TANTALUM	TEMSVA 1C 225M-8L
C8	4550002980	S.TANTALUM	TEMSVA 1C 225M-8L
C9	4030006890	S.CERAMIC	C1808 JF 1H 103Z-T-A
C10	4550000530	S.TANTALUM	TESVA 1V 104M1-8L
C11	4030006860	S.CERAMIC	C1808 JB 1H 102K-T-A

S.=Surface mount



[PLL-A BOARD]

REF. NO.	ORDER NO.	DESCRIPTION	
C13	4030007150	S.CERAMIC	C1808 CH 1H 151J-T-A
C14	4030006880	S.CERAMIC	C1808 JB 1H 102K-T-A
C15	4030006970	S.CERAMIC	C1808 CH 1H 080D-T-A
C16	4030006910	S.CERAMIC	C1808 CH 1H 0R5C-T-A
C19	4030006900	S.CERAMIC	C1808 JB 1E 103K-T-A
C20	4030006880	S.CERAMIC	C1808 JB 1H 102K-T-A
C22	4030006880	S.CERAMIC	C1808 JB 1H 102K-T-A
C23	4030006880	S.CERAMIC	C1808 JB 1H 102K-T-A
C24	4030006880	S.CERAMIC	C1808 JB 1H 102K-T-A
C25	4030006870	S.CERAMIC	C1808 SL 1H 270J-T-A
C26	4030006850	S.CERAMIC	C1808 JB 1H 471K-T-A
C27	4550000530	S.TANTALUM	TESVA 1V 104M1-8L
W1	7030003880	S.JUMPER	ERJ3GE JPW V
EP1	0910037803	PCB	B 3739C
EP2	6510008580	LEADFRAM	PT2.0-0.7-16.5 (K)
MP1	8510007870	CASE	1128 VCO CASE

[YGR-A BOARD]

REF. NO.	ORDER NO.	DESCRIPTION	
Q1	1530002340	S.TRANSISTOR 2SC2954-T2B	
Q2	1530002340	S.TRANSISTOR 2SC2954-T2B	
D1	1790000880	S.DIODE	MA133 (TX)
D2	1790000590	S.DIODE	MA110 (TW)
L1	8200002590	S.COIL	NL 252018T-039J
L2	8200002430	S.COIL	NL 252018T-082J
L3	8200002580	S.COIL	NL 252018T-033J
L4	8200002420	S.COIL	NL 252018T-088J
R1	7030003450	S.RESISTOR	ERJ3GEYJ 122 V (1.2 kΩ)
R2	7030003680	S.RESISTOR	ERJ3GEYJ 104 V (100 kΩ)
R3	7030003280	S.RESISTOR	ERJ3GEYJ 470 V (47 Ω)
R4	7030003680	S.RESISTOR	ERJ3GEYJ 104 V (100 kΩ)
R5	7030003430	S.RESISTOR	ERJ3GEYJ 821 V (820 Ω)
R6	7030003440	S.RESISTOR	ERJ3GEYJ 102 V (1 kΩ)
R7	7030003280	S.RESISTOR	ERJ3GEYJ 470 V (47 Ω)
C1	4030006880	S.CERAMIC	C1808 SL 1H 220J-T-A
C2	4030006540	S.CERAMIC	C1808 SL 1H 030C-T-A
C4	4030006880	S.CERAMIC	C1808 JB 1H 102K-T-A
C5	4030006880	S.CERAMIC	C1808 JB 1H 102K-T-A
C6	4030006810	S.CERAMIC	C1808 SL 1H 100D-T-A
C7	4030006680	S.CERAMIC	C1808 SL 1H 300J-T-A
C8	4030006880	S.CERAMIC	C1808 JB 1H 102K-T-A
C9	4030006880	S.CERAMIC	C1808 JB 1H 102K-T-A
C10	4030006880	S.CERAMIC	C1808 SL 1H 220J-T-A
C11	4030006880	S.CERAMIC	C1808 JB 1H 102K-T-A
EP1	0910038022	PCB	B 3543B
EP2	6910003110	LEADFRAM	HFB2.0-0.7-8 (N)

[VCO-A BOARD]

REF. NO.	ORDER NO.	DESCRIPTION	
Q1	1560000490	S.FET	2SK508 K52 T2B
Q2	1590001620	S.TRANSISTOR	UN521F (TX)
D1	1720000460	S.VARICAP	1SV167-T1
L1	8200001580	S.COIL	LER 015T 1R8M
L3	8200001580	S.COIL	LER 015T 1R8M
L4	8130002620	S.COIL	LB-291
L5	8200001230	S.COIL	MLF2012A 1R0M-T
R1	7030003320	S.RESISTOR	ERJ3GEYJ 101 V (100 Ω)
R2	7030003670	S.RESISTOR	ERJ3GEYJ 823 V (82 kΩ)
R3	7030003400	S.RESISTOR	ERJ3GEYJ 471 V (470 Ω)
R4	7030003280	S.RESISTOR	ERJ3GEYJ 470 V (47 Ω)
R5	7030003600	S.RESISTOR	ERJ3GEYJ 223 V (22 kΩ)
R6	7030003320	S.RESISTOR	ERJ3GEYJ 101 V (100 Ω)
R7	7030003320	S.RESISTOR	ERJ3GEYJ 101 V (100 Ω)
R8	7030003400	S.RESISTOR	ERJ3GEYJ 471 V (470 Ω)
C1	4030006880	S.CERAMIC	C1808 JB 1H 102K-T-A
C2	4030006880	S.CERAMIC	C1808 JB 1H 102K-T-A
C3	4030006880	S.CERAMIC	C1808 JB 1H 102K-T-A
C4	4030006880	S.CERAMIC	C1808 JB 1H 102K-T-A
C5	4030006880	S.CERAMIC	C1808 JB 1H 102K-T-A
C6	4030006880	S.CERAMIC	C1808 JB 1H 102K-T-A
C7	4030006880	S.CERAMIC	C1808 JB 1H 102K-T-A
C8	4030006880	S.CERAMIC	C1808 JB 1H 102K-T-A
C9	4030006850	S.CERAMIC	C1808 JB 1H 471K-T-A
C10	4030006920	S.CERAMIC	C1808 CH 1H 010C-T-A
C11	4030006880	S.CERAMIC	C1808 JB 1H 102K-T-A
C12	4030007080	S.CERAMIC	C1808 CH 1H 390J-T-A
EP1	0910038821	PCB	B 3546A
EP2	6510008580	LEADFRAM	PT2.0-0.7-16.5 (K)

[APC-A BOARD]

REF. NO.	ORDER NO.	DESCRIPTION	
IC1	1110003340	S.IC	μPC358GR-T1
Q1	1530002280	S.TRANSISTOR 2SC4081 T107 S	
Q2	1590001320	S.TRANSISTOR DTC143ZU T107	
D1	1790001000	S.ZENER	MA8082-L (TX)
R1	7030003560	S.RESISTOR	ERJ3GEYJ 103 V (10 kΩ)
R2	7030003560	S.RESISTOR	ERJ3GEYJ 103 V (10 kΩ)
R3	7030003560	S.RESISTOR	ERJ3GEYJ 103 V (10 kΩ)
R4	7030003320	S.RESISTOR	ERJ3GEYJ 101 V (100 Ω)
R5	7030003790	S.RESISTOR	ERJ3GEYJ 824 V (820 kΩ)
R6	7030003600	S.RESISTOR	ERJ3GEYJ 223 V (22 kΩ)
R7	7030003320	S.RESISTOR	ERJ3GEYJ 101 V (100 Ω)
R8	7030003640	S.RESISTOR	ERJ3GEYJ 473 V (47 kΩ)
R9	7030003570	S.RESISTOR	ERJ3GEYJ 123 V (12 kΩ)
R10	7030003720	S.RESISTOR	ERJ3GEYJ 224 V (220 kΩ)
R11	7030003640	S.RESISTOR	ERJ3GEYJ 473 V (47 kΩ)
R12	7030003640	S.RESISTOR	ERJ3GEYJ 473 V (47 kΩ)
C1	4030006880	S.CERAMIC	C1808 JB 1H 102K-T-A
C2	4550004230	S.TANTALUM	F95 1A108MTAAQ2
C3	4030006880	S.CERAMIC	C1808 JB 1H 102K-T-A
C4	4030006880	S.CERAMIC	C1808 JB 1H 102K-T-A
C5	4030006880	S.CERAMIC	C1808 JB 1H 102K-T-A
C6	4030006880	S.CERAMIC	C1808 JB 1H 102K-T-A
C7	4030006880	S.CERAMIC	C1808 JB 1H 102K-T-A
C8	4030006880	S.CERAMIC	C1808 JB 1H 102K-T-A

S.=Surface mount

[APC-A BOARD]

REF. NO.	ORDER NO.	DESCRIPTION	
EP1	0910038002	PCB	B 3542B
EP2	6910003110	LEADFRAM	HFB2.0-0.7-8 (N)

[IF-A BOARD]

REF. NO.	ORDER NO.	DESCRIPTION	
IC1	1110002780	S.IC	MC3371DR
IC2	1110002750	S.IC	TA75S01F (TE85R)
IC3	1110000980	S.IC	NJM4558M (T1)
Q1	1590001450	S.FET	2SJ144-GR (TE85R)
Q5	1580000540	S.FET	2SK880-Y (TE85R)
Q7	1590001800	S.TRANSISTOR	UMH2 TN
Q8	1530002890	S.TRANSISTOR	2SC4118-GR (TE85R)
Q9	1590001790	S.TRANSISTOR	UN511D (TX)
D1	1790000980	S.DIODE	MA742 (TX)
D2	1790000980	S.DIODE	MA742 (TX)
L1	6200002090	S.COIL	ELJFB 681K-F
R1	7030003760	S.RESISTOR	ERJ3GEYJ 474 V (470 kΩ)
R2	7030003520	S.RESISTOR	ERJ3GEYJ 472 V (4.7 kΩ)
R5	7030003480	S.RESISTOR	ERJ3GEYJ 222 V (2.2 kΩ)
R6	7030003400	S.RESISTOR	ERJ3GEYJ 471 V (470 Ω)
R7	7030003680	S.RESISTOR	ERJ3GEYJ 104 V (100 kΩ)
R10	7030003680	S.RESISTOR	ERJ3GEYJ 683 V (68 kΩ)
R11	7030003800	S.RESISTOR	ERJ3GEYJ 105 V (1 MΩ)
R12	7030003680	S.RESISTOR	ERJ3GEYJ 683 V (68 kΩ)
R13	7030003680	S.RESISTOR	ERJ3GEYJ 104 V (100 kΩ)
R14	7030003580	S.RESISTOR	ERJ3GEYJ 103 V (10 kΩ)
R15	7030003570	S.RESISTOR	ERJ3GEYJ 123 V (12 kΩ)
R16	7030003830	S.RESISTOR	ERJ3GEYJ 185 V (1.8 MΩ)
R18	7030003800	S.RESISTOR	ERJ3GEYJ 223 V (22 kΩ)
R19	7030003510	S.RESISTOR	ERJ3GEYJ 392 V (3.9 kΩ)
R20	7030003800	S.RESISTOR	ERJ3GEYJ 105 V (1 MΩ)
R21	7030003800	S.RESISTOR	ERJ3GEYJ 105 V (1 MΩ)
R22	7030003580	S.RESISTOR	ERJ3GEYJ 103 V (10 kΩ)
R23	7030003320	S.RESISTOR	ERJ3GEYJ 101 V (100 Ω)
R24	7030003580	S.RESISTOR	ERJ3GEYJ 103 V (10 kΩ)
R26	7030003680	S.RESISTOR	ERJ3GEYJ 104 V (100 kΩ)
R27	7030003750	S.RESISTOR	ERJ3GEYJ 394 V (390 kΩ)
R28	7030003760	S.RESISTOR	ERJ3GEYJ 474 V (470 kΩ)
R29	7030003630	S.RESISTOR	ERJ3GEYJ 393 V (39 kΩ)
R30	7030003630	S.RESISTOR	ERJ3GEYJ 393 V (39 kΩ)
R31	7030003630	S.RESISTOR	ERJ3GEYJ 393 V (39 kΩ)
C1	4030006900	S.CERAMIC	C1808 JB 1E 103K-T-A
C2	4030006860	S.CERAMIC	C1808 JB 1H 102K-T-A
C3	4030006890	S.CERAMIC	C1808 SL 1H 330J-T-A
C4	4030006860	S.CERAMIC	C1808 JB 1H 102K-T-A
C5	4030006860	S.CERAMIC	C1808 JB 1H 102K-T-A
C6	4030006850	S.CERAMIC	C1808 JB 1H 471K-T-A
C7	4030006850	S.CERAMIC	C1808 JB 1H 471K-T-A
C8	4030006880	S.CERAMIC	C2012 JF 1C 105Z-T-A
C9	4030006900	S.CERAMIC	C1808 JB 1E 103K-T-A
C10	4550004700	S.TANTALUM	F95 1V474MQAAQ2
C11	4030006900	S.CERAMIC	C1808 JB 1E 103K-T-A
C12	4030006870	S.CERAMIC	C1808 JB 1H 222K-T-A
C13	4030009580	S.CERAMIC	C1808 JB 1H 681K-T-A
C14	4030006900	S.CERAMIC	C1808 JB 1E 103K-T-A
C15	4030006900	S.CERAMIC	C1808 JB 1E 103K-T-A
C16	4030006900	S.CERAMIC	C1808 JB 1E 103K-T-A
C17	4030006870	S.CERAMIC	C2012 JB 1H 153K-T-A
C18	4030006830	S.CERAMIC	C1808 JF 1C 104Z-T-A
C19	4030006830	S.CERAMIC	C1808 JF 1C 104Z-T-A

[IF-A BOARD]

REF. NO.	ORDER NO.	DESCRIPTION	
C20	4030006900	S.CERAMIC	C1808 JB 1E 103K-T-A
C21	4030006780	S.CERAMIC	C1808 SL 1H 181J-T-A
C22	4030006900	S.CERAMIC	C1808 JB 1E 103K-T-A
C23	4030006900	S.CERAMIC	C1808 JB 1E 103K-T-A
C24	4030006830	S.CERAMIC	C1808 JF 1C 104Z-T-A
C25	4030006830	S.CERAMIC	C1808 JF 1C 104Z-T-A
C26	4030006830	S.CERAMIC	C1808 JF 1C 104Z-T-A
C27	4030006880	S.CERAMIC	C1808 JB 1H 472K-T-A
C28	4030006870	S.CERAMIC	C1808 JB 1H 222K-T-A
C29	4030006880	S.CERAMIC	C1808 JB 1H 472K-T-A
C30	4030006830	S.CERAMIC	C1808 SL 1H 331J-T-A
EP1	0910038171	PCB	B 3541A
EP2	6910003110	LEADFRAM	HFB2.0-0.7-8 (N)

[MAIN-B UNIT]

REF. NO.	ORDER NO.	DESCRIPTION	
IC1	1130004200	S.IC	TC4S66F (TE85R)
IC2	1150000750	IC	SC1054
IC3	1110001971	S.IC	μPC1876G-T1
IC4	1130005810	S.IC	BU4094BF-T1
IC5	1130005810	S.IC	BU4094BF-T1
IC7	1130005820	S.IC	TC4S584F(TE85R)
IC8	1110003090	IC	LA4425A
IC9	1110002750	S.IC	TA75S01F (TE85R)
Q2	1530002840	S.TRANSISTOR	2SC4118-Y (TE85R)
Q3	1510000780	S.TRANSISTOR	2SA1586-Y (TE85R)
Q4	1560000540	S.FET	2SK880-Y (TE85R)
Q5	1530002840	S.TRANSISTOR	2SC4118-Y (TE85R)
Q6	1530002920	S.TRANSISTOR	2SC4226-T2 R25
Q7	1530002920	S.TRANSISTOR	2SC4226-T2 R25
Q8	1520000660	TRANSISTOR	2SB1184 Q
Q9	1530002920	S.TRANSISTOR	2SC4226-T2 R25
Q10	1580000480	S.FET	3SK184-S (TX)
Q11	1590000430	S.TRANSISTOR	DTC144EU T107
Q12	1580000650	S.FET	2SK1577-2-T7
Q13	1580000480	S.FET	3SK184-S (TX)
Q14	1580000490	S.FET	3SK186-2-T7
Q15	1590000430	S.TRANSISTOR	DTC144EU T107
Q16	1580000480	S.FET	3SK184-S (TX)
Q17	1530002920	S.TRANSISTOR	2SC4226-T2 R25
Q18	1590000430	S.TRANSISTOR	DTC144EU T107
Q19	1590000430	S.TRANSISTOR	DTC144EU T107
Q20	1530002840	S.TRANSISTOR	2SC4118-Y (TE85R)
Q21	1510000890	S.TRANSISTOR	2SA1734 (TE12R)
Q22	1590000430	S.TRANSISTOR	DTC144EU T107
Q23	1590001040	S.TRANSISTOR	DTA113ZU T107
Q24	1590000430	S.TRANSISTOR	DTC144EU T107
Q25	1590001040	S.TRANSISTOR	DTA113ZU T107
Q26	1590000430	S.TRANSISTOR	DTC144EU T107
Q27	1590001040	S.TRANSISTOR	DTA113ZU T107
Q28	1590000430	S.TRANSISTOR	DTC144EU T107
Q30	1590001540	S.TRANSISTOR	UMD6 TL
Q31	1590000880	S.TRANSISTOR	DTC114EU T107
Q32	1510000690	S.TRANSISTOR	2SA1734 (TE12R)
Q33	1590001600	S.TRANSISTOR	UMD3 TL
Q34	1590000880	S.TRANSISTOR	DTC114EU T107
Q35	1590001330	S.TRANSISTOR	DTA114EU T107
Q36	1590000680	S.TRANSISTOR	DTC114EU T107
Q37	1590000680	S.TRANSISTOR	DTC114EU T107
Q38	1580000530	S.FET	2SK880-GR (TE85R)
Q39	1530002840	S.TRANSISTOR	2SC4118-Y (TE85R)
Q40	1590000430	S.TRANSISTOR	DTC144EU T107

S.=Surface mount

[MAIN-B UNIT]

REF. NO.	ORDER NO.	DESCRIPTION	
D2	1790000820	S.DIODE	MA132K (TX)
D3	1750000280	S.DIODE	1SS352 (TPH3)
D4	1790000620	S.DIODE	MA77 (TW)
D5	1790000450	S.DIODE	MA862 (TX)
D6	1710000310	DIODE	MI407
D7	1790000980	S.DIODE	MA742 (TX)
D8	1790000980	S.DIODE	MA742 (TX)
D9	1790000700	DIODE	DSA3A1
D11	1790000820	S.DIODE	MA132K (TX)
D13	1790001000	S.ZENER	MA8082-L (TX)
D15	1790000450	S.DIODE	MA862 (TX)
D16	1790000450	S.DIODE	MA862 (TX)
D17	1710000730	S.DIODE	MI809-T11
D18	1710000730	S.DIODE	MI809-T11
D19	1790001010	S.ZENER	MA8043-L (TX)
D20	1720000270	S.VARICAP	1SV217 (TPH2)
D21	1720000270	S.VARICAP	1SV217 (TPH2)
D22	1750000270	S.DIODE	1SS301 (TE85R)
D23	1750000270	S.DIODE	1SS301 (TE85R)
D24	1750000270	S.DIODE	1SS301 (TE85R)
D25	1750000270	S.DIODE	1SS301 (TE85R)
D27	1720000270	S.VARICAP	1SV217 (TPH2)
D28	1790000810	S.DIODE	MA132A (TX) (AUS)
F11	2020000550	CERAMIC	CFUM455E
F12	2010001500	XTAL	FL-186 UM-1 42.250MHz
F13	2040000580	DIELECTR	TUCF2A0445W014B03 (USA)
F13	2040000570	DIELECTR	TUCF2A0435W014B03 (EUR, AUS, SEA)
F14	2040000580	DIELECTR	TUCF2A0445W014B03 (USA)
F14	2040000570	DIELECTR	TUCF2A0435W014B03 (EUR, AUS, SEA)
X1	6050007410	XTAL	CR-335
X2	6070000100	DISCRI	CDBM455C18
X3	60500008180	XTAL	CR-408 UM-1 42.705 MHz
L1	6200002580	S.COIL	NL 252018T-033J
L2	6200002580	S.COIL	NL 252018T-018K
L3	6200002580	S.COIL	NL 252018T-018K
L4	6200002000	S.COIL	NL 252018T-3R3J
L5	6200002420	S.COIL	NL 252018T-068J
L6	6200002580	S.COIL	NL 252018T-018K
L7	6170000180	COIL	LW-19
L8	6110001520	COIL	LA-232
L9	6110001520	COIL	LA-232
L12	6150003980	S.COIL	LS-458
L13	6200002580	S.COIL	NL 252018T-018K
L14	6200002590	S.COIL	NL 252018T-039J
L15	6200001980	S.COIL	NL 252018T-1R0J
L16	6200002800	S.COIL	NL 252018T-047J
L17	6200002570	S.COIL	NL 252018T-022K
L18	6200002570	S.COIL	NL 252018T-022K
L19	6200002800	S.COIL	NL 252018T-047J
L20	6200002570	S.COIL	NL 252018T-022K
L21	6200002580	S.COIL	NL 252018T-018K
L22	6200002550	S.COIL	NL 252018T-010K
L24	6110001520	COIL	LA-232
L25	6110001520	COIL	LA-232
L26	6200002570	S.COIL	NL 252018T-022K
L27	6200002570	S.COIL	NL 252018T-022K
L28	6200002840	S.COIL	NL 252018T-R15J
L29	6150003980	S.COIL	LS-455
L30	6150003980	S.COIL	LS-455
L31	6200002800	S.COIL	NL 252018T-047J
L32	6200002550	S.COIL	NL 252018T-010K
L33	6200002810	S.COIL	NL 252018T-R47J
L34	6200002180	S.COIL	NL 252018T-R12J
R4	7030003590	S.RESISTOR	ERJ3GEYJ 183 V (18 kΩ)
R5	7030003840	S.RESISTOR	ERJ3GEYJ 473 V (47 kΩ)
R6	7030003440	S.RESISTOR	ERJ3GEYJ 102 V (1 kΩ)

[MAIN-B UNIT]

REF. NO.	ORDER NO.	DESCRIPTION	
R7	7030003440	S.RESISTOR	ERJ3GEYJ 102 V (1 kΩ)
R8	7030003320	S.RESISTOR	ERJ3GEYJ 101 V (100 Ω)
R9	7030003440	S.RESISTOR	ERJ3GEYJ 102 V (1 kΩ)
R10	7030003400	S.RESISTOR	ERJ3GEYJ 471 V (470 Ω)
R11	7030003680	S.RESISTOR	ERJ3GEYJ 104 V (100 kΩ)
R12	7030003720	S.RESISTOR	ERJ3GEYJ 224 V (220 kΩ)
R13	7030003200	S.RESISTOR	ERJ3GEYJ 100 V (10 Ω)
R14	7030003720	S.RESISTOR	ERJ3GEYJ 224 V (220 kΩ)
R15	7030003800	S.RESISTOR	ERJ3GEYJ 105 V (1 MΩ)
R17	7030003520	S.RESISTOR	ERJ3GEYJ 472 V (4.7 kΩ)
R18	7030003630	S.RESISTOR	ERJ3GEYJ 393 V (39 kΩ)
R19	7310003590	S.TRIMMER	EVM-1XSX50 B24 (203)
R20	7030003280	S.RESISTOR	ERJ3GEYJ 470 V (47 Ω)
R21	7030003280	S.RESISTOR	ERJ3GEYJ 470 V (47 Ω)
R22	7030003520	S.RESISTOR	ERJ3GEYJ 472 V (4.7 kΩ)
R23	7030003410	S.RESISTOR	ERJ3GEYJ 561 V (560 Ω)
R24	7030000260	S.RESISTOR	MCR10EZHZ 100 Ω (101)
R25	7030003520	S.RESISTOR	ERJ3GEYJ 472 V (4.7 kΩ)
R26	7030003280	S.RESISTOR	ERJ3GEYJ 470 V (47 Ω)
R27	7030003520	S.RESISTOR	ERJ3GEYJ 472 V (4.7 kΩ)
R28	7030003420	S.RESISTOR	ERJ3GEYJ 681 V (680 Ω)
R29	7030003320	S.RESISTOR	ERJ3GEYJ 101 V (100 Ω)
R30	7030003200	S.RESISTOR	ERJ3GEYJ 100 V (10 Ω)
R31	7030003280	S.RESISTOR	ERJ3GEYJ 470 V (47 Ω)
R32	7030003220	S.RESISTOR	ERJ3GEYJ 150 V (15 Ω)
R34	7030003280	S.RESISTOR	ERJ3GEYJ 330 V (33 Ω)
R35	7030003440	S.RESISTOR	ERJ3GEYJ 102 V (1 kΩ)
R37	7030003480	S.RESISTOR	ERJ3GEYJ 222 V (2.2 kΩ)
R38	7030003370	S.RESISTOR	ERJ3GEYJ 271 V (270 Ω)
R39	7030003230	S.RESISTOR	ERJ3GEYJ 180 V (18 Ω)
R40	7030003370	S.RESISTOR	ERJ3GEYJ 271 V (270 Ω)
R41	7030003440	S.RESISTOR	ERJ3GEYJ 102 V (1 kΩ)
R42	7310003770	S.TRIMMER	EVM-1XSX50 B34 (303)
R43	7030003570	S.RESISTOR	ERJ3GEYJ 123 V (12 kΩ)
R44	7030001070	S.RESISTOR	MCR50JZHZ 33 Ω (330)
R46	7030001190	S.RESISTOR	MCR50JZHZ 330 Ω (331)
R47	7030001130	S.RESISTOR	MCR50JZHZ 100 Ω (101)
R48	7030000410	S.RESISTOR	MCR10EZHZ 1.8 kΩ (182)
R49	7030000280	S.RESISTOR	MCR10EZHZ 150 Ω (151)
R50	7030000410	S.RESISTOR	MCR10EZHZ 1.8 kΩ (182)
R51	7030000280	S.RESISTOR	MCR10EZHZ 150 Ω (151)
R53	7310003580	S.TRIMMER	EVM-1XSX50 B15 (104)
R54	7030003320	S.RESISTOR	ERJ3GEYJ 101 V (100 Ω)
R55	7030003530	S.RESISTOR	ERJ3GEYJ 562 V (5.6 kΩ)
R56	7030003560	S.RESISTOR	ERJ3GEYJ 103 V (10 kΩ)
R57	7030003840	S.RESISTOR	ERJ3GEYJ 225 V (2.2 MΩ)
R58	7030000250	S.RESISTOR	MCR10EZHZ 82 Ω (820)
R59	7030003250	S.RESISTOR	ERJ3GEYJ 270 V (27 Ω)
R61	7030003440	S.RESISTOR	ERJ3GEYJ 102 V (1 kΩ)
R65	7030003420	S.RESISTOR	ERJ3GEYJ 681 V (680 Ω)
R66	7030003320	S.RESISTOR	ERJ3GEYJ 101 V (100 Ω)
R67	7030003440	S.RESISTOR	ERJ3GEYJ 102 V (1 kΩ)
R68	7030003320	S.RESISTOR	ERJ3GEYJ 101 V (100 Ω)
R69	7030003360	S.RESISTOR	ERJ3GEYJ 221 V (220 Ω)
R70	7030003800	S.RESISTOR	ERJ3GEYJ 223 V (22 kΩ)
R71	7030003280	S.RESISTOR	ERJ3GEYJ 470 V (47 Ω)
R72	7030003360	S.RESISTOR	ERJ3GEYJ 221 V (220 Ω)
R73	7030003240	S.RESISTOR	ERJ3GEYJ 220 V (22 Ω)
R74	7030003280	S.RESISTOR	ERJ3GEYJ 470 V (47 Ω)
R76	7030003280	S.RESISTOR	ERJ3GEYJ 470 V (47 Ω)
R77	7030003310	S.RESISTOR	ERJ3GEYJ 820 V (82 Ω)
R78	7030003680	S.RESISTOR	ERJ3GEYJ 104 V (100 kΩ)
R79	7030003620	S.RESISTOR	ERJ3GEYJ 333 V (33 kΩ)
R80	7030003500	S.RESISTOR	ERJ3GEYJ 332 V (3.3 kΩ)
R81	7030003520	S.RESISTOR	ERJ3GEYJ 472 V (4.7 kΩ)
R82	7030000240	S.RESISTOR	MCR10EZHZ 68 Ω (680)
R83	7030003270	S.RESISTOR	ERJ3GEYJ 390 V (39 Ω)
R84	7030003560	S.RESISTOR	ERJ3GEYJ 103 V (10 kΩ)
R85	7030003440	S.RESISTOR	ERJ3GEYJ 102 V (1 kΩ)
R86	7030003200	S.RESISTOR	ERJ3GEYJ 100 V (10 Ω)
R87	7030003430	S.RESISTOR	ERJ3GEYJ 821 V (820 Ω)
R88	7030004030	S.RESISTOR	ERJ3GEYJ 5R8 V (5.8 Ω)
R89	7030003430	S.RESISTOR	ERJ3GEYJ 821 V (820 Ω)
R90	7030003320	S.RESISTOR	ERJ3GEYJ 101 V (100 Ω)
R91	7030003880	S.RESISTOR	ERJ3GEYJ 104 V (100 kΩ)
R92	7030003540	S.RESISTOR	ERJ3GEYJ 682 V (6.8 kΩ)

S.=Surface mount

[MAIN-B UNIT]

REF. NO.	ORDER NO.	DESCRIPTION
R93	7030003250	S.RESISTOR ERJ3GEYJ 270 V (27 Ω)
R94	7030003250	S.RESISTOR ERJ3GEYJ 270 V (27 Ω)
R95	7030003280	S.RESISTOR ERJ3GEYJ 470 V (47 Ω)
R96	7030003280	S.RESISTOR ERJ3GEYJ 470 V (47 Ω)
R97	7030003320	S.RESISTOR ERJ3GEYJ 101 V (100 Ω)
R98	7030003620	S.RESISTOR ERJ3GEYJ 333 V (33 k Ω)
R99	7030003480	S.RESISTOR ERJ3GEYJ 222 V (2.2 k Ω)
R100	7030003520	S.RESISTOR ERJ3GEYJ 472 V (4.7 k Ω)
R101	7030003370	S.RESISTOR ERJ3GEYJ 271 V (270 Ω)
R102	7030003680	S.RESISTOR ERJ3GEYJ 104 V (100 k Ω)
R103	7030003320	S.RESISTOR ERJ3GEYJ 101 V (100 Ω)
R104	7030003590	S.RESISTOR ERJ3GEYJ 183 V (18 k Ω)
R105	7030003680	S.RESISTOR ERJ3GEYJ 104 V (100 k Ω)
R106	7030003280	S.RESISTOR ERJ3GEYJ 470 V (47 Ω)
R107	7030003680	S.RESISTOR ERJ3GEYJ 104 V (100 k Ω)
R108	7030003680	S.RESISTOR ERJ3GEYJ 104 V (100 k Ω)
R109	7030003480	S.RESISTOR ERJ3GEYJ 222 V (2.2 k Ω)
R110	7030003520	S.RESISTOR ERJ3GEYJ 472 V (4.7 k Ω)
R110	7030003530	S.RESISTOR ERJ3GEYJ 582 V (5.8 k Ω) (EUR, AUS, SEA)
R112	7030003680	S.RESISTOR ERJ3GEYJ 104 V (100 k Ω)
R113	7030003680	S.RESISTOR ERJ3GEYJ 104 V (100 k Ω)
R114	7030003370	S.RESISTOR ERJ3GEYJ 271 V (270 Ω)
R115	7030003560	S.RESISTOR ERJ3GEYJ 103 V (10 k Ω)
R116	7030003560	S.RESISTOR ERJ3GEYJ 103 V (10 k Ω)
R117	7030003430	S.RESISTOR ERJ3GEYJ 821 V (820 Ω)
R118	7520000080	S.POSISTOR PTH9C23 BB 471Q-T
R120	7030000420	S.RESISTOR MCR10EZJH 2.2 k Ω (222)
R121	7030000100	S.RESISTOR MCR10EZJH 4.7 Ω (4R7)
R124	7030003680	S.RESISTOR ERJ3GEYJ 104 V (100 k Ω)
R125	7030003500	S.RESISTOR ERJ3GEYJ 332 V (3.3 k Ω)
R126	7030003640	S.RESISTOR ERJ3GEYJ 473 V (47 k Ω)
R127	7510000470	S.THERMISTOR TN20-2V221LT
R128	7310003610	S.TRIMMER EVM-1XSX50 B14 (103)
R129	7030003630	S.RESISTOR ERJ3GEYJ 393 V (39 k Ω)
R130	7030003640	S.RESISTOR ERJ3GEYJ 473 V (47 k Ω)
R132	7030003610	S.RESISTOR ERJ3GEYJ 273 V (27 k Ω)
R133	7030003200	S.RESISTOR ERJ3GEYJ 100 V (10 Ω)
R135	7030003640	S.RESISTOR ERJ3GEYJ 473 V (47 k Ω)
R136	7030003560	S.RESISTOR ERJ3GEYJ 103 V (10 k Ω)
R137	7030003560	S.RESISTOR ERJ3GEYJ 103 V (10 k Ω)
R138	7510000620	S.THERMISTOR TN20-4C104LT
R139	7030003640	S.RESISTOR ERJ3GEYJ 473 V (47 k Ω)
R140	7030003740	S.RESISTOR ERJ3GEYJ 334 V (330 k Ω)
R141	7030003520	S.RESISTOR ERJ3GEYJ 472 V (4.7 k Ω)
R142	7030003680	S.RESISTOR ERJ3GEYJ 104 V (100 k Ω)
R143	7030003680	S.RESISTOR ERJ3GEYJ 104 V (100 k Ω)
R144	7030003680	S.RESISTOR ERJ3GEYJ 104 V (100 k Ω)
R145	7030003680	S.RESISTOR ERJ3GEYJ 104 V (100 k Ω)
R146	7030003480	S.RESISTOR ERJ3GEYJ 222 V (2.2 k Ω)
C3	4030006860	S.CERAMIC C1808 JB 1H 102K-T-A
C5	4030006980	S.CERAMIC C1808 CH 1H 070D-T-A
C6	4030006960	S.CERAMIC C1808 CH 1H 050C-T-A
C8	4030006860	S.CERAMIC C1808 JB 1H 102K-T-A
C9	4030006860	S.CERAMIC C1808 JB 1H 102K-T-A
C10	4030006860	S.CERAMIC C1808 JB 1H 102K-T-A
C11	4030006860	S.CERAMIC C1808 JB 1H 102K-T-A
C12	4030006860	S.CERAMIC C1808 JB 1H 102K-T-A
C13	4030006860	S.CERAMIC C1808 JB 1H 102K-T-A
C14	4030006860	S.CERAMIC C1808 JB 1H 102K-T-A
C15	4030006860	S.CERAMIC C1808 JB 1H 102K-T-A
C16	4510005300	S.ELECTRO-LITIC ECEV1AA330P
C17	4030006860	S.CERAMIC C1808 JB 1H 102K-T-A
C18	4030006860	S.CERAMIC C1808 JB 1H 102K-T-A
C19	4030006860	S.CERAMIC C2012 JF 1C 105Z-T-A
C20	4030006860	S.CERAMIC C1808 JB 1H 102K-T-A
C21	4030006860	S.CERAMIC C1808 JB 1H 102K-T-A
C22	4030006860	S.CERAMIC C1808 JB 1H 102K-T-A
C23	4030006570	S.CERAMIC C1808 SL 1H 060D-T-A
C24	4030006580	S.CERAMIC C1808 SL 1H 070D-T-A
C25	4030006630	S.CERAMIC C1808 SL 1H 150J-T-A
C26	4030006580	S.CERAMIC C1808 SL 1H 070D-T-A

[MAIN-B UNIT]

REF. NO.	ORDER NO.	DESCRIPTION
C27	4030006860	S.CERAMIC C1808 JB 1H 102K-T-A
C28	4030006860	S.CERAMIC C1808 JB 1H 102K-T-A
C29	4030006860	S.CERAMIC C1808 SL 1H 220J-T-A
C30	4030006810	S.CERAMIC C1808 SL 1H 100D-T-A
C31	4030006860	S.CERAMIC C1808 SL 1H 220J-T-A
C32	4030006860	S.CERAMIC C1808 SL 1H 220J-T-A
C33	4030006570	S.CERAMIC C1808 JB 1H 060D-T-A
C34	4030006860	S.CERAMIC C1808 JB 1H 102K-T-A
C35	4030006860	S.CERAMIC C1808 JB 1H 102K-T-A
C36	4550004140	S.TANTALUM F95 1C106MWCAQ2
C37	4030006540	S.CERAMIC C1808 JB 1H 030C-T-A
C38	4030006540	S.CERAMIC C1808 SL 1H 030C-T-A
C39	4550004140	S.TANTALUM F95 1C106MWCAQ2
C40	4550004140	S.TANTALUM F95 1C106MWCAQ2
C41	4030006860	S.CERAMIC C1808 JB 1H 102K-T-A
C42	4030006860	S.CERAMIC C1808 JB 1H 102K-T-A
C43	4030006860	S.CERAMIC C1808 JB 1H 102K-T-A
C44	4550004140	S.TANTALUM F95 1C106MWCAQ2
C45	4030006860	S.CERAMIC C1808 JB 1H 102K-T-A
C46	4010003840	CERAMIC DD06 SL 070D 500V
C47	4030006860	S.CERAMIC C1808 JB 1H 102K-T-A
C48	4030006860	S.CERAMIC C1808 JB 1H 102K-T-A
C49	4030006860	S.CERAMIC C1808 JB 1H 102K-T-A
C50	4010004120	CERAMIC DD07 B 102K 500V
C51	4010003840	CERAMIC DD06 SL 070D 500V
C52	4030006860	S.CERAMIC C1808 JB 1H 102K-T-A
C53	4030006860	S.CERAMIC C1808 JB 1H 102K-T-A
C54	4030006860	S.CERAMIC C1808 JB 1H 102K-T-A
C55	4030006860	S.CERAMIC C1808 JB 1H 102K-T-A
C56	4010003860	CERAMIC DD06 SL 100D 500V
C57	4030009900	S.CERAMIC GR42-2 CK 020C 500PT
C58	4030006860	S.CERAMIC C1808 JB 1H 102K-T-A
C59	4030006860	S.CERAMIC C1808 JB 1H 102K-T-A
C60	4510004600	ELECTROLITIC 16 MV 1000 HC
C61	4030004760	S.CERAMIC C2012 JF 1E 104Z-T-A
C62	4030006830	S.CERAMIC C1808 JF 1C 104Z-T-A
C63	4030006990	S.CERAMIC C1808 CH 1H 080D-T-A
C64	4030006990	S.CERAMIC C1808 CH 1H 080D-T-A
C65	4030007170	S.CERAMIC C1808 CH 1H 221J-T-A
C66	4030006860	S.CERAMIC C1808 JB 1H 102K-T-A
C67	4030006890	S.CERAMIC C1808 JF 1H 103Z-T-A
C68	4030006890	S.CERAMIC C1808 JF 1H 103Z-T-A
C69	4510004630	S.ELECTRO-LITIC ECEV1CA100R
C70	4030006860	S.CERAMIC C1808 JB 1H 102K-T-A
C71	4030006860	S.CERAMIC C1808 JB 1H 102K-T-A
C74	4030006860	S.CERAMIC C1808 JB 1H 102K-T-A
C75	4030006860	S.CERAMIC C1808 JB 1H 102K-T-A
C76	4030006860	S.CERAMIC C1808 JB 1H 102K-T-A
C77	4030006860	S.CERAMIC C1808 JB 1H 102K-T-A
C78	4030006860	S.CERAMIC C1808 JB 1H 102K-T-A
C79	4030006710	S.CERAMIC C1808 SL 1H 470J-T-A
C80	4030006860	S.CERAMIC C1808 JB 1H 102K-T-A
C81	4030006540	S.CERAMIC C1808 SL 1H 030C-T-A
C82	4030006860	S.CERAMIC C1808 JB 1H 102K-T-A
C83	4030006520	S.CERAMIC C1808 SL 1H 010C-T-A
C84	4030006580	S.CERAMIC C1808 SL 1H 070D-T-A
C85	4030006860	S.CERAMIC C1808 JB 1H 102K-T-A
C86	4030006860	S.CERAMIC C1808 JB 1H 102K-T-A
C87	4030006860	S.CERAMIC C1808 JB 1H 102K-T-A
C88	4030006860	S.CERAMIC C1808 JB 1H 102K-T-A
C90	4030006860	S.CERAMIC C1808 JB 1H 102K-T-A
C91	4030006860	S.CERAMIC C1808 JB 1H 102K-T-A
C92	4030006540	S.CERAMIC C1808 SL 1H 030C-T-A
C93	4030006860	S.CERAMIC C1808 JB 1H 102K-T-A
C94	4030006860	S.CERAMIC C1808 JB 1H 102K-T-A
C95	4030006530	S.CERAMIC C1808 SL 1H 020C-T-A
C96	4610001810	S.TRIMMER TZBX4Z030BA110700
C97	4030006860	S.CERAMIC C1808 JB 1H 102K-T-A
C98	4030006860	S.CERAMIC C1808 JB 1H 102K-T-A
C99	4030006860	S.CERAMIC C1808 JB 1H 102K-T-A
C100	4030006860	S.CERAMIC C1808 JB 1H 102K-T-A
C101	4030006630	S.CERAMIC C1808 JF 1C 104Z-T-A
C102	4030006860	S.CERAMIC C1808 JB 1H 102K-T-A
C103	4030006610	S.CERAMIC C1808 SL 1H 100D-T-A
C104	4030006560	S.CERAMIC C1808 SL 1H 050C-T-A

S.=Surface mount

[MAIN-B UNIT]

REF. NO.	ORDER NO.	DESCRIPTION
C105	4030006810	S.CERAMIC C1808 SL 1H 100D-T-A
C106	4030006880	S.CERAMIC C1808 JB 1H 102K-T-A
C107	4030006880	S.CERAMIC C1808 JB 1H 102K-T-A
C108	4030006880	S.CERAMIC C1808 JB 1H 102K-T-A
C109	4030006880	S.CERAMIC C1808 JB 1H 102K-T-A
C110	4030006880	S.CERAMIC C1808 JB 1H 102K-T-A
C111	4030006880	S.CERAMIC C1808 SL 1H 070D-T-A
C112	4030006880	S.CERAMIC C1808 JB 1H 102K-T-A
C113	4030006550	S.CERAMIC C1808 SL 1H 040C-T-A
C114	4030006880	S.CERAMIC C1808 JB 1H 102K-T-A
C115	4030006880	S.CERAMIC C1808 JB 1H 102K-T-A
C121	4030006880	S.CERAMIC C1808 JB 1H 102K-T-A
C123	4030006540	S.CERAMIC C1808 SL 1H 030C-T-A
C124	4030006880	S.CERAMIC C1808 JB 1H 102K-T-A
C125	4030006880	S.CERAMIC C1808 JB 1H 102K-T-A
C127	4030006840	S.CERAMIC C1808 SL 1H 180J-T-A
C128	4030006880	S.CERAMIC C1808 JB 1H 102K-T-A
C129	4030006880	S.CERAMIC C1808 JB 1H 102K-T-A
C132	4030006540	S.CERAMIC C1808 SL 1H 030C-T-A
C133	4030006540	S.CERAMIC C1808 SL 1H 030C-T-A
C134	4030006710	S.CERAMIC C1808 SL 1H 470J-T-A
C135	4030006710	S.CERAMIC C1808 SL 1H 470J-T-A
C136	4030006710	S.CERAMIC C1808 SL 1H 470J-T-A
C137	4030006710	S.CERAMIC C1808 SL 1H 470J-T-A
C138	4030006710	S.CERAMIC C1808 SL 1H 470J-T-A
C139	4030006710	S.CERAMIC C1808 SL 1H 470J-T-A
C140	4030006710	S.CERAMIC C1808 SL 1H 470J-T-A
C141	4030006710	S.CERAMIC C1808 SL 1H 470J-T-A
C142	4030006710	S.CERAMIC C1808 SL 1H 470J-T-A
C143	4030006710	S.CERAMIC C1808 SL 1H 470J-T-A
C144	4030006710	S.CERAMIC C1808 SL 1H 470J-T-A
C145	4030006710	S.CERAMIC C1808 SL 1H 470J-T-A
C146	4030006710	S.CERAMIC C1808 SL 1H 470J-T-A
C147	4030006710	S.CERAMIC C1808 SL 1H 470J-T-A
C148	4030006710	S.CERAMIC C1808 SL 1H 470J-T-A
C149	4030006710	S.CERAMIC C1808 SL 1H 470J-T-A
C150	4030006860	S.CERAMIC C1808 JB 1H 102K-T-A
C151	4030006830	S.CERAMIC C1808 JF 1C 104Z-T-A
C152	4030006830	S.CERAMIC C1808 JF 1C 104Z-T-A
C153	4030006860	S.CERAMIC C1808 JB 1H 102K-T-A
C154	4030006830	S.CERAMIC C1808 JF 1C 104Z-T-A
C155	4030006830	S.CERAMIC C1808 JF 1C 104Z-T-A
C156	4030006830	S.CERAMIC C1808 JF 1C 104Z-T-A
C157	4030006830	S.CERAMIC C1808 JF 1C 104Z-T-A
C158	4030006830	S.CERAMIC C1808 JF 1C 104Z-T-A
C159	4030006830	S.CERAMIC C1808 JF 1C 104Z-T-A
C160	4030006830	S.CERAMIC C1808 JF 1C 104Z-T-A
C161	4030006830	S.CERAMIC C1808 JF 1C 104Z-T-A
C162	4030006860	S.CERAMIC C1808 JB 1H 102K-T-A
C163	4030006590	S.CERAMIC C1808 SL 1H 080D-T-A
C164	4030006860	S.CERAMIC C1808 JB 1H 102K-T-A
C166	4030006860	S.CERAMIC C1808 JB 1H 102K-T-A
C167	4030006860	S.CERAMIC C1808 JB 1H 102K-T-A
C168	4030006860	S.CERAMIC C1808 JB 1H 102K-T-A
C169	4030006860	S.CERAMIC C1808 JB 1H 102K-T-A
C173	4030008780	S.CERAMIC C2012 X7R 1C 104K-T-A
C174	4030008630	S.CERAMIC C1808 JF 1C 104Z-T-A
C175	4510004590	ELECTROLITIC 16 MV 470 HC
C176	4510005370	S.ELECTRO-LITIC ECEV1AA221P
C177	4030008780	S.CERAMIC C2012 X7R 1C 104K-T-A
C178	4030006870	S.CERAMIC C1808 SL 1H 270J-T-A
C179	4030006530	S.CERAMIC C1808 SL 1H 020C-T-A
C180	4030006710	S.CERAMIC C1808 SL 1H 470J-T-A
C182	4030006900	S.CERAMIC C1808 JB 1E 103K-T-A
C183	4550004080	S.TANTALUM F95 0J108MSAAQ2
C184	4550004230	S.TANTALUM F95 1A108MTAAQ2
C185	4510005300	S.ELECTRO-LITIC ECEV1AA330P
C186	4550004140	S.TANTALUM F95 1C108MWCAQ2
C187	4550004080	S.TANTALUM F95 0J108MSAAQ2
C188	4030006880	S.CERAMIC C1808 JB 1H 102K-T-A
C189	4030006880	S.CERAMIC C1808 JB 1H 102K-T-A
C190	4030006830	S.CERAMIC C1808 JF 1C 104Z-T-A
C191	4030006540	S.CERAMIC C1808 SL 1H 030C-T-A
C192	4030006530	S.CERAMIC C1808 SL 1H 020C-T-A

[MAIN-B UNIT]

REF. NO.	ORDER NO.	DESCRIPTION
C193	4030006530	S.CERAMIC C1808 SL 1H 020C-T-A
C194	4030006530	S.CERAMIC C1808 SL 1H 020C-T-A
C195	4030006530	S.CERAMIC C1808 SL 1H 020C-T-A
C196	4030006850	S.CERAMIC C1808 JB 1H 471K-T-A
C197	4030006860	S.CERAMIC C1808 JB 1H 102K-T-A
C198	4030006860	S.CERAMIC C1808 JB 1H 102K-T-A
C199	4030006850	S.CERAMIC C1808 JB 1H 471K-T-A
C200	4030006850	S.CERAMIC C1808 JB 1H 471K-T-A
C201	4030006750	S.CERAMIC C1808 SL 1H 101J-T-A
W4	8900001980	CABLE OPC-188 [430 (440) MHz ANT]
W5	8900004520	CABLE OPC-373A
W6	8900004520	CABLE OPC-373A
W8	7030003860	S.JUMPER ERJ3GE JPW V
W9	7030003860	S.JUMPER ERJ3GE JPW V
W10	7120000380	JUMPER JPW 01 R-01
W11	7030003860	S.JUMPER ERJ3GE JPW V
W12	7120000380	JUMPER JPW 01 R-01
J1	8510014710	CONNECTOR 52330-1017
J2	8510014710	CONNECTOR 52330-1017
J3	8510014960	S.CONNECTOR B2B-ZR-SM3-TF
J4	8510014960	S.CONNECTOR B2B-ZR-SM3-TF
J5	8510014960	S.CONNECTOR B2B-ZR-SM3-TF
J6	8510003250	CONNECTOR TMP-J01X-A2
J8	8450001330	CONNECTOR HSJ1332-01-020 [430 (440) MHz SP]
EP1	0910036805	PCB B 3544E
MP1	8930005320	SPACER Filter spacer
MP2	8930005320	SPACER Filter spacer
MP3	8930005320	SPACER Filter spacer
MP4	8930024850	TERMINAL 1128 terminal
MP5	8950003290	SHEET Glass sticker
MP6	8510007450	PLATE VCO shield (C)
MP7	8930013530	SHEET Insulating sheet BC
MP8	8930001160	SPRING Ground contact FX 22
MP9	8510007450	PLATE VCO shield (C) FX976
MP10	8930013530	SHEET Insulating sheet BC
MP12	8930032400	SPONGE 1352 I-sponge

[PLL-B BOARD]

REF. NO.	ORDER NO.	DESCRIPTION
IC1	1130005700	S.IC M56780FP
Q2	1560000530	S.FET 2SK880-GR (TE85R)
Q3	1530003010	S.TRANSISTOR 2SC4117-GR (TE85R)
Q5	1590001610	S.TRANSISTOR UMH10 TN
Q6	1560000490	S.FET 2SK508 K52 T2B
Q7	1530002940	S.TRANSISTOR 2SC4228-T2 R44
Q8	1530002940	S.TRANSISTOR 2SC4228-T2 R44
Q9	1530003010	S.TRANSISTOR 2SC4117-GR (TE85R)
D1	1720000220	S.VARICAP 1SV166-T2B
D2	1720000460	S.VARICAP 1SV167-T1
D3	1790000490	S.DIODE HSM88AS-TR
L1	6200001560	S.COIL LER 015T R68M
L2	6200001570	S.COIL LER 015T 1R0M
L3	6200002590	S.COIL NL 252018T-039J
L4	6200001570	S.COIL LER 015T 1R0M

S.=Surface mount

[PLL-B BOARD]

REF. NO.	ORDER NO.	DESCRIPTION	
L5	6200001570	S.COIL	LER 015T 1R0M
L6	6200001230	S.COIL	MLF2012A 1R0M-T
L7	6200002690	S.COIL	MLF1608A 1R0M-T
R1	7030003640	S.RESISTOR	ERJ3GEYJ 473 V (47 kΩ)
R2	7030003480	S.RESISTOR	ERJ3GEYJ 222 V (2.2 kΩ)
R3	7030003620	S.RESISTOR	ERJ3GEYJ 333 V (33 kΩ)
R7	7030003550	S.RESISTOR	ERJ3GEYJ 822 V (8.2 kΩ)
R8	7030003410	S.RESISTOR	ERJ3GEYJ 561 V (560 Ω)
R9	7030003430	S.RESISTOR	ERJ3GEYJ 821 V (820 Ω)
R10	7030003320	S.RESISTOR	ERJ3GEYJ 101 V (100 Ω)
R11	7030003360	S.RESISTOR	ERJ3GEYJ 221 V (220 Ω)
R12	7030000460	S.RESISTOR	MCR10EZHZJ 4.7 kΩ (472)
R13	7030003550	S.RESISTOR	ERJ3GEYJ 822 V (8.2 kΩ)
R14	7030003520	S.RESISTOR	ERJ3GEYJ 472 V (4.7 kΩ)
R15	7030003320	S.RESISTOR	ERJ3GEYJ 101 V (100 Ω)
R16	7030003520	S.RESISTOR	ERJ3GEYJ 472 V (4.7 kΩ)
R17	7030003280	S.RESISTOR	ERJ3GEYJ 470 V (47 Ω)
R18	7030003560	S.RESISTOR	ERJ3GEYJ 103 V (10 kΩ)
R19	7030003280	S.RESISTOR	ERJ3GEYJ 470 V (47 Ω)
R20	7030003330	S.RESISTOR	ERJ3GEYJ 121 V (120 Ω)
R21	7030003400	S.RESISTOR	ERJ3GEYJ 471 V (470 Ω)
R22	7030003520	S.RESISTOR	ERJ3GEYJ 472 V (4.7 kΩ)
R23	7030003410	S.RESISTOR	ERJ3GEYJ 561 V (560 Ω)
R24	7030003380	S.RESISTOR	ERJ3GEYJ 331 V (330 Ω)
R28	7030003500	S.RESISTOR	ERJ3GEYJ 332 V (3.3 kΩ)
R29	7030003410	S.RESISTOR	ERJ3GEYJ 561 V (560 Ω)
R30	7030003360	S.RESISTOR	ERJ3GEYJ 221 V (220 Ω)
R33	7030003440	S.RESISTOR	ERJ3GEYJ 102 V (1 kΩ)
C1	4030006860	S.CERAMIC	C1608 JB 1H 102K-T-A
C5	4030008760	S.CERAMIC	C2012 X7R 1C 104K-T-A
C6	4030008660	S.CERAMIC	C2012 JF 1C 105Z-T-A
C7	4550002980	S.TANTALUM	TEMSVA 1C 225M-8L
C8	4550002980	S.TANTALUM	TEMSVA 1C 225M-8L
C9	4030006890	S.CERAMIC	C1608 JF 1H 103Z-T-A
C10	4550000530	S.TANTALUM	TESVA 1V 104M1-8L
C11	4030006860	S.CERAMIC	C1608 JB 1H 102K-T-A
C12	4030006860	S.CERAMIC	C1608 JB 1H 102K-T-A
C13	4030007110	S.CERAMIC	C1608 CH 1H 680J-T-A
C14	4030006860	S.CERAMIC	C1608 JB 1H 102K-T-A
C15	4030006550	S.CERAMIC	C1608 SL 1H 040C-T-A
C16	4030006910	S.CERAMIC	C1608 CH 1H 0R5C-T-A
C17	4030006860	S.CERAMIC	C1608 JB 1H 102K-T-A
C18	4030006850	S.CERAMIC	C1608 JB 1H 471K-T-A
C19	4030006900	S.CERAMIC	C1608 JB 1E 103K-T-A
C20	4030006860	S.CERAMIC	C1608 JB 1H 102K-T-A
C22	4030006860	S.CERAMIC	C1608 JB 1H 102K-T-A
C23	4030006860	S.CERAMIC	C1608 JB 1H 102K-T-A
C24	4030006860	S.CERAMIC	C1608 JB 1H 102K-T-A
C25	4030006870	S.CERAMIC	C1608 SL 1H 270J-T-A
C26	4030006860	S.CERAMIC	C1608 JB 1H 102K-T-A
W1	7030003860	S.JUMPER	ERJ3GE JPW V
EP1	0910037812	PCB	B 3740B
EP2	6510008580	LEADFRAM	PT2.0-0.7-16.5 (K)
MP1	8510007670	CASE	1126 VCO case
MP2	8510008070	PLATE	1126 VCO plate
MP3	8930027970	SHEET	Insulating sheet CQ

[VCO-B BOARD]

REF. NO.	ORDER NO.	DESCRIPTION	
Q1	1560000490	S.FET	2SK508 K52 T2B
Q2	1590001820	S.TRANSISTOR	UN521F (TX)

[VCO-B BOARD]

REF. NO.	ORDER NO.	DESCRIPTION	
D1	1720000180	S.VARICAP	1SV164-T2B
L1	6200001580	S.COIL	LER 015T 1R8M
L3	6200001580	S.COIL	LER 015T 1R8M
L4	6130002620	S.COIL	LB-291
R1	7030003320	S.RESISTOR	ERJ3GEYJ 101 V (100 Ω)
R4	7030003280	S.RESISTOR	ERJ3GEYJ 470 V (47 Ω)
R7	7030003320	S.RESISTOR	ERJ3GEYJ 101 V (100 Ω)
R8	7030003400	S.RESISTOR	ERJ3GEYJ 471 V (470 Ω)
C1	4030006860	S.CERAMIC	C1608 JB 1H 102K-T-A
C3	4030006860	S.CERAMIC	C1608 JB 1H 102K-T-A
C4	4030006860	S.CERAMIC	C1608 JB 1H 102K-T-A
C5	4030006860	S.CERAMIC	C1608 JB 1H 102K-T-A
C6	4030006860	S.CERAMIC	C1608 JB 1H 102K-T-A
C10	4030006920	S.CERAMIC	C1608 CH 1H 010C-T-A
C11	4030006860	S.CERAMIC	C1608 JB 1H 102K-T-A
C12	4030007130	S.CERAMIC	C1608 CH 1H 101J-T-A
W1	7030003860	S.JUMPER	ERJ3GE JPW V
W2	7030003860	S.JUMPER	ERJ3GE JPW V
EP1	0910035703	PCB	B 3540C
EP2	6510008580	LEADFRAM	PT2.0-0.7-16.5 (K)

[YGR-B BOARD]

REF. NO.	ORDER NO.	DESCRIPTION	
Q1	1530002680	S.TRANSISTOR	2SC3357-T2
Q2	1530002340	S.TRANSISTOR	2SC2954-T2B
D1	1790000860	S.DIODE	MA133 (TX)
L2	6200002550	S.COIL	NL 252018T-010K
L4	6200002620	S.COIL	NL 252018T-015K
R1	7030003410	S.RESISTOR	ERJ3GEYJ 561 V (560 Ω)
R2	7030003520	S.RESISTOR	ERJ3GEYJ 472 V (4.7 kΩ)
R3	7030003240	S.RESISTOR	ERJ3GEYJ 220 V (22 Ω)
R4	7030003520	S.RESISTOR	ERJ3GEYJ 472 V (4.7 kΩ)
R5	7030003340	S.RESISTOR	ERJ3GEYJ 151 V (150 Ω)
R6	7030003440	S.RESISTOR	ERJ3GEYJ 102 V (1 kΩ)
R7	7030003240	S.RESISTOR	ERJ3GEYJ 220 V (22 Ω)
C1	4030006860	S.CERAMIC	C1608 JB 1H 102K-T-A
C4	4030006860	S.CERAMIC	C1608 JB 1H 102K-T-A
C5	4030006860	S.CERAMIC	C1608 JB 1H 102K-T-A
C6	4030006590	S.CERAMIC	C1608 SL 1H 080D-T-A
C8	4030006860	S.CERAMIC	C1608 JB 1H 102K-T-A
C9	4030006860	S.CERAMIC	C1608 JB 1H 102K-T-A
C10	4030006560	S.CERAMIC	C1608 SL 1H 050C-T-A
C11	4030006860	S.CERAMIC	C1608 JB 1H 102K-T-A
W1	7030003860	S.JUMPER	ERJ3GE JPW V
W2	7030000010	S.JUMPER	MCR10EZHZJ JPW (000)
W3	7030000010	S.JUMPER	MCR10EZHZJ JPW (000)
EP1	0910036852	PCB	B 3549B
EP2	6910003110	LEADFRAM	HFB2.0-0.7-8 (N)

S.=Surface mount

[APC-B BOARD]

REF. NO.	ORDER NO.	DESCRIPTION	
IC1	1110003340	S.IC	μPC358GR-T1
Q1	1530002280	S.TRANSISTOR 2SC4081 T107 S	
Q2	1590000430	S.TRANSISTOR DTC144EU T107	
D1	1790001000	S.ZENER	MA8062-L (TX)
R1	7030003620	S.RESISTOR	ERJ3GEYJ 333 V (33 kΩ)
R2	7030003640	S.RESISTOR	ERJ3GEYJ 473 V (47 kΩ)
R3	7030003560	S.RESISTOR	ERJ3GEYJ 103 V (10 kΩ)
R4	7030003320	S.RESISTOR	ERJ3GEYJ 101 V (100 Ω)
R5	7030003790	S.RESISTOR	ERJ3GEYJ 824 V (820 kΩ)
R6	7030003600	S.RESISTOR	ERJ3GEYJ 223 V (22 kΩ)
R7	7030003320	S.RESISTOR	ERJ3GEYJ 101 V (100 Ω)
R8	7030003640	S.RESISTOR	ERJ3GEYJ 473 V (47 kΩ)
R9	7030003570	S.RESISTOR	ERJ3GEYJ 123 V (12 kΩ)
R10	7030003720	S.RESISTOR	ERJ3GEYJ 224 V (220 kΩ)
R11	7030003640	S.RESISTOR	ERJ3GEYJ 473 V (47 kΩ)
R12	7030003640	S.RESISTOR	ERJ3GEYJ 473 V (47 kΩ)
C1	4030006860	S.CERAMIC	C1608 JB 1H 102K-T-A
C2	4550004250	S.TANTALUM	F95 1A226MYC
C3	4030006860	S.CERAMIC	C1608 JB 1H 102K-T-A
C4	4030006860	S.CERAMIC	C1608 JB 1H 102K-T-A
C5	4030006860	S.CERAMIC	C1608 JB 1H 102K-T-A
C6	4030006860	S.CERAMIC	C1608 JB 1H 102K-T-A
C7	4030006860	S.CERAMIC	C1608 JB 1H 102K-T-A
C8	4030006860	S.CERAMIC	C1608 JB 1H 102K-T-A
EP1	0910036842	PCB	B 3548B
EP2	6910003110	LEADFRAM	HFB2.0-0.7-8 (N)

[IF-B BOARD]

REF. NO.	ORDER NO.	DESCRIPTION	
C5	4030006860	S.CERAMIC	C1608 JB 1H 102K-T-A
C8	4030006850	S.CERAMIC	C1608 JB 1H 471K-T-A
C7	4030006850	S.CERAMIC	C1608 JB 1H 471K-T-A
C8	4030006860	S.CERAMIC	C2012 JF 1C 105Z-T-A
C9	4030006900	S.CERAMIC	C1608 JB 1E 103K-T-A
C10	4550004700	S.TANTALUM	F95 1V474MQAAQ2
C11	4030006900	S.CERAMIC	C1608 JB 1E 103K-T-A
C13	4030009580	S.CERAMIC	C1608 JB 1H 681K-T-A
C14	4030006900	S.CERAMIC	C1608 JB 1E 103K-T-A
C15	4030006900	S.CERAMIC	C1608 JB 1E 103K-T-A
C16	4030006900	S.CERAMIC	C1608 JB 1E 103K-T-A
C17	4030006470	S.CERAMIC	C2012 JB 1H 153K-T-A
C18	4030006630	S.CERAMIC	C1608 JB 1C 104Z-T-A
C19	4030006630	S.CERAMIC	C1608 JF 1C 104Z-T-A
C25	4030006630	S.CERAMIC	C1608 JF 1C 104Z-T-A
C26	4030006630	S.CERAMIC	C1608 JF 1C 104Z-T-A
C27	4030006870	S.CERAMIC	C1608 JB 1H 222K-T-A
C28	4030006630	S.CERAMIC	C1608 SL 1H 331J-T-A
C29	4030006880	S.CERAMIC	C1608 JB 1H 472K-T-A
EP1	0910036831	PCB	B 3547A
EP2	6910003110	LEADFRAM	HFB2.0-0.7-8 (N)

[RFT-B BOARD]

REF. NO.	ORDER NO.	DESCRIPTION	
Q1	1530002940	S.TRANSISTOR 2SC4228-T2 R44	
Q2	1580000360	S.FET 3SK177-T2B U73	
Q3	1590001470	S.TRANSISTOR UN9213 (TX)	
Q4	1530002900	S.TRANSISTOR 2SC4228-T2 R45	
D1	1790000620	S.DIODE	MA77 (TW)
L1	6200002550	S.COIL	NL 252018T-010K
R1	7030003540	S.RESISTOR	ERJ3GEYJ 682 V (6.8 kΩ)
R2	7030003600	S.RESISTOR	ERJ3GEYJ 223 V (22 kΩ)
R3	7030003380	S.RESISTOR	ERJ3GEYJ 331 V (330 Ω)
R4	7030003560	S.RESISTOR	ERJ3GEYJ 103 V (10 kΩ)
R5	7030003340	S.RESISTOR	ERJ3GEYJ 151 V (150 Ω)
R6	7030003560	S.RESISTOR	ERJ3GEYJ 103 V (10 kΩ)
R7	7030003270	S.RESISTOR	ERJ3GEYJ 390 V (39 Ω)
R8	7030003400	S.RESISTOR	ERJ3GEYJ 471 V (470 Ω)
R9	7030003560	S.RESISTOR	ERJ3GEYJ 103 V (10 kΩ)
R10	7030003440	S.RESISTOR	ERJ3GEYJ 102 V (1 kΩ)
C1	4030006540	S.CERAMIC	C1608 SL 1H 030C-T-A
C2	4030006540	S.CERAMIC	C1608 SL 1H 030C-T-A
C3	4030006550	S.CERAMIC	C1608 SL 1H 040C-T-A
C4	4030006860	S.CERAMIC	C1608 JB 1H 102K-T-A
C5	4030006560	S.CERAMIC	C1608 SL 1H 050C-T-A
C6	4030006550	S.CERAMIC	C1608 SL 1H 040C-T-A
C7	4030006700	S.CERAMIC	C1608 SL 1H 390J-T-A
C8	4030006860	S.CERAMIC	C1608 JB 1H 102K-T-A
C9	4030006530	S.CERAMIC	C1608 SL 1H 020C-T-A
C10	4030006860	S.CERAMIC	C1608 JB 1H 102K-T-A
C11	4030006860	S.CERAMIC	C1608 JB 1H 102K-T-A
EP1	0910037201	PCB	B 3681A
EP2	6910003110	LEADFRAM	HFB2.0-0.7-8 (N)

[IF-B BOARD]

REF. NO.	ORDER NO.	DESCRIPTION	
IC1	1110002780	S.IC	MC3371DR
IC2	1110002750	S.IC	TA75S01F (TE85R)
IC3	1110000960	S.IC	NJM4558M (T1)
D1	1790000980	S.DIODE	MA742 (TX)
R1	7030003760	S.RESISTOR	ERJ3GEYJ 474 V (470 kΩ)
R2	7030003520	S.RESISTOR	ERJ3GEYJ 472 V (4.7 kΩ)
R5	7030003480	S.RESISTOR	ERJ3GEYJ 222 V (2.2 kΩ)
R6	7030003400	S.RESISTOR	ERJ3GEYJ 471 V (470 Ω)
R7	7030003680	S.RESISTOR	ERJ3GEYJ 104 V (100 kΩ)
R10	7030003660	S.RESISTOR	ERJ3GEYJ 683 V (68 kΩ)
R11	7030003800	S.RESISTOR	ERJ3GEYJ 105 V (1 MΩ)
R14	7030003560	S.RESISTOR	ERJ3GEYJ 103 V (10 kΩ)
R15	7030003570	S.RESISTOR	ERJ3GEYJ 123 V (12 kΩ)
R16	7030003830	S.RESISTOR	ERJ3GEYJ 185 V (1.8 MΩ)
R18	7030003600	S.RESISTOR	ERJ3GEYJ 223 V (22 kΩ)
R19	7030003510	S.RESISTOR	ERJ3GEYJ 392 V (3.9 kΩ)
R20	7030003800	S.RESISTOR	ERJ3GEYJ 105 V (1 MΩ)
R21	7030003800	S.RESISTOR	ERJ3GEYJ 105 V (1 MΩ)
R22	7030003630	S.RESISTOR	ERJ3GEYJ 393 V (39 kΩ)
R23	7030003630	S.RESISTOR	ERJ3GEYJ 393 V (39 kΩ)
R24	7030003630	S.RESISTOR	ERJ3GEYJ 393 V (39 kΩ)
C1	4030006900	S.CERAMIC	C1608 JB 1E 103K-T-A
C2	4030006860	S.CERAMIC	C1608 JB 1H 102K-T-A
C3	4030006690	S.CERAMIC	C1608 SL 1H 330J-T-A
C4	4030006860	S.CERAMIC	C1608 JB 1H 102K-T-A

S.=Surface mount

[MAIN-C BOARD]

REF. NO.	ORDER NO.	DESCRIPTION	
IC1	1130004200	S.IC	TC4S66F (TE85R)
IC2	1150000530	IC	SC1066
IC3	1180000970	S.IC	AN78L05M-(E1)
IC5	1130005810	S.IC	BU4094BF-T1
IC7	1110001971	S.IC	μPC1676G-T1
IC8	1110003090	IC	LA4425A
IC9	1110001971	S.IC	μPC1676G-T1
Q1	1530002280	S.TRANSISTOR	2SC4081 T107 S
Q2	1530002920	S.TRANSISTOR	2SC4226-T2 R25
Q5	1520000680	TRANSISTOR	2SB1184 Q
Q6	1510000700	S.TRANSISTOR	2SA1736 (TE12R)
Q7	1530002690	S.TRANSISTOR	2SC4116-GR (TE85R)
Q8	1530003120	S.TRANSISTOR	2SC3120 (TE85R)
Q9	1580000380	S.FET	3SK177-T2B U73
Q10	1530003040	S.TRANSISTOR	2SC4095 R47-T2
Q11	1590000430	S.TRANSISTOR	DTC144EU T107
Q12	1590000820	FET	MGF1302-15
Q14	1530002280	S.TRANSISTOR	2SC4081 T107 S
Q15	1590000430	S.TRANSISTOR	DTC144EU T107
Q16	1590000430	S.TRANSISTOR	DTC144EU T107
Q17	1590001040	S.TRANSISTOR	DTA113ZU T107
Q18	1590000430	S.TRANSISTOR	DTC144EU T107
Q19	1590001040	S.TRANSISTOR	DTA113ZU T107
Q20	1590000430	S.TRANSISTOR	DTC144EU T107
Q21	1590001040	S.TRANSISTOR	DTA113ZU T107
Q22	1590000430	S.TRANSISTOR	DTC144EU T107
Q23	1580000480	S.FET	3SK184-S (TX)
Q24	1530002900	S.TRANSISTOR	2SC4226-T2 R45
Q27	1590000680	S.TRANSISTOR	DTC114EU T107
Q28	1510000690	S.TRANSISTOR	2SA1734 (TE12R)
Q29	1590000430	S.TRANSISTOR	DTC144EU T107
Q30	1590000430	S.TRANSISTOR	DTC144EU T107
Q31	1590001040	S.TRANSISTOR	DTA113ZU T107
Q35	1510000770	S.TRANSISTOR	2SA1586-GR (TE85R)
Q36	1590001600	S.TRANSISTOR	UMD3 TL
Q37	1590000680	S.TRANSISTOR	DTC114EU T107
Q38	1590001330	S.TRANSISTOR	DTA114EU T107
Q39	1590000680	S.TRANSISTOR	DTC114EU T107
Q40	1590000680	S.TRANSISTOR	DTC114EU T107
Q41	1510000580	S.TRANSISTOR	2SA1362-GR (TE85R)
Q42	1590001540	S.TRANSISTOR	UMD6 TL
Q43	1560000530	S.FET	2SK880-GR (TE85R)
Q44	1590000430	S.TRANSISTOR	DTC144EU T107
D5	1750000080	S.DIODE	1SS196 (TE85R)
D6	1790000490	S.DIODE	HSM88AS-TR
D7	1710000730	S.DIODE	M1809-T11
D8	1790001000	S.ZENER	MA8082-L (TX)
D9	1790000980	S.DIODE	MA742 (TX)
D10	1750000270	S.DIODE	1SS301 (TE85R)
D11	1750000260	S.DIODE	1SS352 (TPH3)
D12	1790001140	S.ZENER	MA8039-L (TX)
D15	1710000730	S.DIODE	M1809-T11
D16	1710000730	S.DIODE	M1809-T11
D17	1710000730	S.DIODE	M1809-T11
D19	1790000450	S.DIODE	MA862 (TX)
D21	1790001010	S.ZENER	MA8043-L (TX)
D24	1750000260	S.DIODE	1SS352 (TPH3)
D26	1750000260	S.DIODE	1SS352 (TPH3)
D27	1750000260	S.DIODE	1SS352 (TPH3)
D28	1750000260	S.DIODE	1SS352 (TPH3)
D29	1750000260	S.DIODE	1SS352 (TPH3)
D30	1750000050	S.DIODE	1SS193 (TE85R)
D31	1790000620	S.DIODE	MA77 (TW)
D32	1790000620	S.DIODE	MA77 (TW)
D33	1790000620	S.DIODE	MA77 (TW)
D34	1790001010	S.ZENER	MA8043-L (TX)
D35	1790000620	S.DIODE	MA77 (TW)
FI1	2020000550	CERAMIC	CFUM455E
FI2	2010001370	MONOLITH	72M15B2 (FL-165)
FI3	2040000230	FILTER	EZF-MC70BT12

[MAIN-C UNIT]

REF. NO.	ORDER NO.	DESCRIPTION	
FI4	2040000230	FILTER	EZF-MC70BT12
X1	6070000100	DISCRI	CDBM455C18
X2	6050008770	XTAL	CR-450 UM-1 71.745 MHz
X3	6050008340	XTAL	CR-414 12.800 MHz
L1	6200002560	S.COIL	NL 252018T-018K
L2	6150004030	S.COIL	LS-464
L3	6150004030	S.COIL	LS-464
L4	6150004030	S.COIL	LS-464
L5	6200002560	S.COIL	NL 252018T-018K
L6	6200002570	S.COIL	NL 252018T-022K
L7	6200002570	S.COIL	NL 252018T-022K
L8	6200002570	S.COIL	NL 252018T-022K
L9	6200002550	S.COIL	NL 252018T-010K
L10	6200002570	S.COIL	NL 252018T-022K
L12	6200002220	S.COIL	LQP31A 4N7J04
L14	6200002910	S.COIL	NL 252018T-R27J
L15	6200002430	S.COIL	NL 252018T-082J
R1	7030003680	S.RESISTOR	ERJ3GEYJ 104 V (100 kΩ)
R2	7310003580	S.TRIMMER	EVM-1XSX50 B15 (104)
R3	7030003540	S.RESISTOR	ERJ3GEYJ 682 V (6.8 kΩ)
R4	7030003380	S.RESISTOR	ERJ3GEYJ 331 V (330 Ω)
R5	7030003220	S.RESISTOR	ERJ3GEYJ 150 V (15 Ω)
R6	7030003380	S.RESISTOR	ERJ3GEYJ 331 V (330 Ω)
R6	7030003370	S.RESISTOR	ERJ3GEYJ 271 V (270 Ω)
R10	7030003520	S.RESISTOR	ERJ3GEYJ 472 V (4.7 kΩ)
R33	7030001170	S.RESISTOR	MCR50JZHJ 220 Ω (221)
R34	7030000980	S.RESISTOR	MCR50JZHJ 5.6 Ω (5R6)
R39	7030001130	S.RESISTOR	MCR50JZHJ 100 Ω (101)
R40	7030005420	S.RESISTOR	ERJ3GEYJ 022 V (2 kΩ)
R41	7030003560	S.RESISTOR	ERJ3GEYJ 103 V (10 kΩ)
R42	7310003590	S.TRIMMER	EVM-1XSX50 B24 (203)
R43	7030003540	S.RESISTOR	ERJ3GEYJ 682 V (6.8 kΩ)
R44	7030001190	S.RESISTOR	MCR50JZHJ 330 Ω (331)
R46	7030003510	S.RESISTOR	ERJ3GEYJ 392 V (3.9 kΩ)
R48	7030003560	S.RESISTOR	ERJ3GEYJ 103 V (10 kΩ)
R49	7030003640	S.RESISTOR	ERJ3GEYJ 473 V (47 kΩ)
R52	7030003530	S.RESISTOR	ERJ3GEYJ 562 V (5.6 kΩ)
R54	7030003500	S.RESISTOR	ERJ3GEYJ 332 V (3.3 kΩ)
R55	7030003340	S.RESISTOR	ERJ3GEYJ 151 V (150 Ω)
R56	7030000260	S.RESISTOR	MCR10EZJH 100 Ω (101)
R57	7030003410	S.RESISTOR	ERJ3GEYJ 561 V (560 Ω)
R58	7030003720	S.RESISTOR	ERJ3GEYJ 224 V (220 kΩ)
R61	7030003320	S.RESISTOR	ERJ3GEYJ 101 V (100 Ω)
R63	7030003340	S.RESISTOR	ERJ3GEYJ 151 V (150 Ω)
R64	7030003480	S.RESISTOR	ERJ3GEYJ 152 V (1.5 kΩ)
R67	7030003360	S.RESISTOR	ERJ3GEYJ 221 V (220 Ω)
R68	7030003600	S.RESISTOR	ERJ3GEYJ 223 V (22 kΩ)
R69	7030003540	S.RESISTOR	ERJ3GEYJ 682 V (6.8 kΩ)
R70	7030003370	S.RESISTOR	ERJ3GEYJ 271 V (270 Ω)
R71	7030003290	S.RESISTOR	ERJ3GEYJ 560 V (56 Ω)
R73	7030003320	S.RESISTOR	ERJ3GEYJ 101 V (100 Ω)
R74	7030003680	S.RESISTOR	ERJ3GEYJ 104 V (100 kΩ)
R75	7030003480	S.RESISTOR	ERJ3GEYJ 222 V (2.2 kΩ)
R76	7030003680	S.RESISTOR	ERJ3GEYJ 104 V (100 kΩ)
R77	7030003600	S.RESISTOR	ERJ3GEYJ 223 V (22 kΩ)
R78	7030003540	S.RESISTOR	ERJ3GEYJ 682 V (6.8 kΩ)
R79	7030003440	S.RESISTOR	ERJ3GEYJ 102 V (1 kΩ)
R80	7030003480	S.RESISTOR	ERJ3GEYJ 222 V (2.2 kΩ)
R81	7310003590	S.TRIMMER	EVM-1XSX50 B24 (203)
R89	7030003460	S.RESISTOR	ERJ3GEYJ 152 V (1.5 kΩ)
R90	7030003490	S.RESISTOR	ERJ3GEYJ 272 V (2.7 kΩ)
R91	7030003350	S.RESISTOR	ERJ3GEYJ 181 V (180 Ω)
R93	7030003560	S.RESISTOR	ERJ3GEYJ 103 V (10 kΩ)
R94	7030003260	S.RESISTOR	ERJ3GEYJ 330 V (33 Ω)
R95	7030003280	S.RESISTOR	ERJ3GEYJ 470 V (47 Ω)
R97	7030003280	S.RESISTOR	ERJ3GEYJ 470 V (47 Ω)
R98	7030003360	S.RESISTOR	ERJ3GEYJ 221 V (220 Ω)
R99	7030003600	S.RESISTOR	ERJ3GEYJ 223 V (22 kΩ)
R101	7030003540	S.RESISTOR	ERJ3GEYJ 682 V (6.8 kΩ)
R107	7030000420	S.RESISTOR	MCR10EZJH 2.2 kΩ (222)

S.=Surface mount



[MAIN-C UNIT]

REF. NO.	ORDER NO.	DESCRIPTION	
R108	7030000280	S.RESISTOR	MCR10EZHZ 100 Ω (101)
R117	7030003640	S.RESISTOR	ERJ3GEYJ 473 V (47 kΩ)
R118	7030003680	S.RESISTOR	ERJ3GEYJ 104 V (100 kΩ)
R119	7310003580	S.TRIMMER	EVM-1XSX50 B15 (104)
R120	7310003580	S.TRIMMER	EVM-1XSX50 B15 (104)
R122	7030003320	S.RESISTOR	ERJ3GEYJ 101 V (100 Ω)
R129	7030003680	S.RESISTOR	ERJ3GEYJ 104 V (100 kΩ)
R130	7030000240	S.RESISTOR	MCR10EZHZ 88 Ω (880)
R132	7510000470	S.THERMISTOR	TN20-2V221LT
R133	7310003610	S.TRIMMER	EVM-1XSX50 B14 (103)
R135	7030003460	S.RESISTOR	ERJ3GEYJ 152 V (1.5 kΩ)
R136	7030003640	S.RESISTOR	ERJ3GEYJ 473 V (47 kΩ)
R139	7030003640	S.RESISTOR	ERJ3GEYJ 473 V (47 kΩ)
R140	7030003200	S.RESISTOR	ERJ3GEYJ 100 V (10 Ω)
R141	7030000300	S.RESISTOR	MCR10EZHZ 220 Ω (221)
R142	7030000300	S.RESISTOR	MCR10EZHZ 220 Ω (221)
R143	7030003580	S.RESISTOR	ERJ3GEYJ 103 V (10 kΩ)
R144	7030003580	S.RESISTOR	ERJ3GEYJ 103 V (10 kΩ)
R145	7030003520	S.RESISTOR	ERJ3GEYJ 472 V (4.7 kΩ)
R146	7030003640	S.RESISTOR	ERJ3GEYJ 473 V (47 kΩ)
R147	7030003440	S.RESISTOR	ERJ3GEYJ 102 V (1 kΩ)
R148	7030003520	S.RESISTOR	ERJ3GEYJ 472 V (4.7 kΩ)
R149	7030000230	S.RESISTOR	MCR10EZHZ 56 Ω (560)
R150	7030003630	S.RESISTOR	ERJ3GEYJ 393 V (39 kΩ)
R151	7030003380	S.RESISTOR	ERJ3GEYJ 221 V (220 Ω)
R152	7030003440	S.RESISTOR	ERJ3GEYJ 102 V (1 kΩ)
R153	7030003400	S.RESISTOR	ERJ3GEYJ 471 V (470 Ω)
R154	7030000220	S.RESISTOR	MCR10EZHZ 47 Ω (470)
R155	7030000220	S.RESISTOR	MCR10EZHZ 47 Ω (470)
R156	7030003690	S.RESISTOR	ERJ3GEYJ 124 V (120 kΩ)
R157	7510000620	S.THERMISTOR	TN20-4C104LT
R158	7030003280	S.RESISTOR	ERJ3GEYJ 470 V (47 Ω)
R159	7030003460	S.RESISTOR	ERJ3GEYJ 152 V (1.5 kΩ)
R160	7030003490	S.RESISTOR	ERJ3GEYJ 272 V (2.7 kΩ)
R161	7030003440	S.RESISTOR	ERJ3GEYJ 102 V (1 kΩ)
R162	7030003540	S.RESISTOR	ERJ3GEYJ 682 V (6.8 kΩ)
C1	4030008680	S.CERAMIC	C2012 JF 1C 105Z-T-A
C2	4030008650	S.CERAMIC	C1808 JB 1H 471K-T-A
C3	4550004240	S.TANTALUM	F95 1A158MVCAQ2
C4	4030008710	S.CERAMIC	C1808 SL 1H 470J-T-A
C6	4030008680	S.CERAMIC	C1808 JB 1H 102K-T-A
C8	4030008940	S.CERAMIC	C1808 CH 1H 030C-T-A
C9	4030008710	S.CERAMIC	C1808 SL 1H 470J-T-A
C10	4030008680	S.CERAMIC	C1808 JB 1H 102K-T-A
C11	4030008680	S.CERAMIC	C1808 JB 1H 102K-T-A
C12	4030008710	S.CERAMIC	C1808 SL 1H 470J-T-A
C16	4030008680	S.CERAMIC	C1808 JB 1H 102K-T-A
C17	4030009540	S.CERAMIC	C1808 CH 1H 1R5B-T-A
C21	4550002750	S.TANTALUM	TESVD2 1A 336M-12L
C35	4030008710	S.CERAMIC	C1808 SL 1H 470J-T-A
C38	4030008710	S.CERAMIC	C1808 SL 1H 470J-T-A
C39	4550002770	S.TANTALUM	TESVD2 1C 226M-12L
C40	4030008650	S.CERAMIC	C1808 JB 1H 471K-T-A
C41	4550000900	S.TANTALUM	TESVC 1C 685M-12L
C44	4030001270	S.MICA	UC232H 0470F
C45	4030008710	S.CERAMIC	C1808 SL 1H 470J-T-A
C46	4030008650	S.CERAMIC	C1808 JB 1H 471K-T-A
C47	4030008680	S.CERAMIC	C1808 JB 1H 102K-T-A
C48	4030008710	S.CERAMIC	C1808 SL 1H 470J-T-A
C50	4030008680	S.CERAMIC	C1808 JB 1H 102K-T-A
C51	4030008650	S.CERAMIC	C1808 JB 1H 471K-T-A
C52	4030008710	S.CERAMIC	C1808 SL 1H 470J-T-A
C56	4030008680	S.CERAMIC	C1808 JB 1H 102K-T-A
C57	4030008650	S.CERAMIC	C1808 JB 1H 471K-T-A
C59	4030008680	S.CERAMIC	C1808 JB 1H 102K-T-A
C60	4510004600	ELECTROLITIC	16 MV 1000 HC
C61	4030008650	S.CERAMIC	C1808 JB 1H 471K-T-A
C62	4030008710	S.CERAMIC	C1808 SL 1H 470J-T-A
C63	4030008630	S.CERAMIC	C1808 JF 1C 104Z-T-A
C64	4030008900	S.CERAMIC	C1808 JB 1E 103K-T-A
C65	4030008680	S.CERAMIC	C1808 JB 1H 102K-T-A
C66	4030008650	S.CERAMIC	C1808 JB 1H 471K-T-A
C67	4510005320	S.ELECTRO-LITIC	ECEV0JA101SP

[MAIN-C UNIT]

REF. NO.	ORDER NO.	DESCRIPTION	
C70	4030008680	S.CERAMIC	C1808 SL 1H 220J-T-A
C71	4030008680	S.CERAMIC	C1808 JB 1H 102K-T-A
C72	4030008680	S.CERAMIC	C1808 JB 1H 472K-T-A
C73	4030008680	S.CERAMIC	C1808 JB 1H 102K-T-A
C74	4030008580	S.CERAMIC	C1808 SL 1H 070D-T-A
C75	4030008580	S.CERAMIC	C1808 SL 1H 070D-T-A
C76	4030008650	S.CERAMIC	C1808 JB 1H 471K-T-A
C77	4030008540	S.CERAMIC	C1808 SL 1H 030C-T-A
C78	4030008680	S.CERAMIC	C1808 JB 1H 102K-T-A
C79	4030008650	S.CERAMIC	C1808 JB 1H 471K-T-A
C80	4030008610	S.CERAMIC	C1808 SL 1H 100D-T-A
C82	4030008520	S.CERAMIC	C1808 SL 1H 010C-T-A
C83	4030008530	S.CERAMIC	C1808 SL 1H 020C-T-A
C84	4030008710	S.CERAMIC	C1808 SL 1H 470J-T-A
C85	4030008650	S.CERAMIC	C1808 JB 1H 471K-T-A
C87	4030008710	S.CERAMIC	C1808 SL 1H 470J-T-A
C88	4030008650	S.CERAMIC	C1808 JB 1H 471K-T-A
C90	4030008530	S.CERAMIC	C1808 SL 1H 020C-T-A
C91	4030008650	S.CERAMIC	C1808 JB 1H 471K-T-A
C92	4030008680	S.CERAMIC	C1808 JB 1H 102K-T-A
C93	4030008650	S.CERAMIC	C1808 JB 1H 471K-T-A
C95	4030008680	S.CERAMIC	C1808 JB 1H 102K-T-A
C96	4030008650	S.CERAMIC	C1808 JB 1H 471K-T-A
C97	4030008680	S.CERAMIC	C1808 JB 1H 1R5C-T-A
C98	4030008650	S.CERAMIC	C1808 JB 1H 471K-T-A
C99	4030008530	S.CERAMIC	C1808 SL 1H 020C-T-A
C100	4030009560	S.CERAMIC	C1808 CH 1H R75B-T-A
C101	4030008440	S.CERAMIC	C1808 SL 1H 1R5C-T-A
C102	4030008680	S.CERAMIC	C1808 JB 1H 102K-T-A
C103	4550004230	S.TANTALUM	F95 1A106MTAAQ2
C104	4030008710	S.CERAMIC	C1808 SL 1H 470J-T-A
C105	4030008650	S.CERAMIC	C1808 JB 1H 471K-T-A
C106	4030008680	S.CERAMIC	C1808 JB 1H 102K-T-A
C107	4030008650	S.CERAMIC	C1808 JB 1H 471K-T-A
C108	4030008710	S.CERAMIC	C1808 SL 1H 470J-T-A
C109	4030008680	S.CERAMIC	C1808 JB 1H 102K-T-A
C110	4030008710	S.CERAMIC	C1808 SL 1H 470J-T-A
C112	4030008710	S.CERAMIC	C1808 SL 1H 470J-T-A
C113	4030008710	S.CERAMIC	C1808 SL 1H 470J-T-A
C114	4030008710	S.CERAMIC	C1808 SL 1H 470J-T-A
C115	4030008710	S.CERAMIC	C1808 SL 1H 470J-T-A
C116	4030008900	S.CERAMIC	C1808 JB 1E 103K-T-A
C117	4030008750	S.CERAMIC	C1808 SL 1H 101J-T-A
C118	4030008530	S.CERAMIC	C1808 SL 1H 020C-T-A
C119	4030008580	S.CERAMIC	C1808 SL 1H 050C-T-A
C120	4030008760	S.CERAMIC	C2012 X7R 1C 104K-T-A
C121	4550004080	S.TANTALUM	F95 0J106MSAAQ2
C122	4550004220	S.TANTALUM	F951A685MSAAQ2
C123	4030008760	S.CERAMIC	C2012 X7R 1C 104K-T-A
C124	4030008680	S.CERAMIC	C1808 JB 1H 102K-T-A
C125	4030008710	S.CERAMIC	C1808 SL 1H 470J-T-A
C126	4030008650	S.CERAMIC	C1808 JB 1H 471K-T-A
C130	4030008710	S.CERAMIC	C1808 SL 1H 470J-T-A
C131	4030008650	S.CERAMIC	C1808 JB 1H 471K-T-A
C132	4030008540	S.CERAMIC	C1808 SL 1H 030C-T-A
C133	4030008710	S.CERAMIC	C1808 SL 1H 470J-T-A
C134	4030008680	S.CERAMIC	C1808 JB 1H 102K-T-A
C135	4030008730	S.CERAMIC	C1808 SL 1H 680J-T-A
C139	4030008650	S.CERAMIC	C1808 JB 1H 471K-T-A
C140	4030008650	S.CERAMIC	C1808 JB 1H 471K-T-A
C141	4030008650	S.CERAMIC	C1808 JB 1H 471K-T-A
C142	4030008650	S.CERAMIC	C1808 JB 1H 471K-T-A
C143	4030008650	S.CERAMIC	C1808 JB 1H 471K-T-A
C144	4030008650	S.CERAMIC	C1808 JB 1H 471K-T-A
C145	4030008900	S.CERAMIC	C1808 JB 1E 103K-T-A
C146	4030008680	S.CERAMIC	C1808 JB 1H 102K-T-A
C147	4030008540	S.CERAMIC	C1808 SL 1H 030C-T-A
C148	4030008680	S.CERAMIC	C1808 JB 1H 102K-T-A
C149	4030008730	S.CERAMIC	C1808 SL 1H 680J-T-A
C150	4030008530	S.CERAMIC	C1808 SL 1H 020C-T-A
C151	4030008570	S.CERAMIC	C1808 SL 1H 080D-T-A
C152	4030008650	S.CERAMIC	C1808 JB 1H 471K-T-A
C153	4030008630	S.CERAMIC	C1808 JF 1C 104Z-T-A
C154	4030004720	S.CERAMIC	C2012 JB 1H 102K-T-A
C155	4030008900	S.CERAMIC	C1808 JB 1E 103K-T-A
C156	4030008710	S.CERAMIC	C1808 SL 1H 470J-T-A

S.=Surface mount

[MAIN-C UNIT]

REF. NO.	ORDER NO.	DESCRIPTION
C157	4030006710	S.CERAMIC C1808 SL 1H 470J-T-A
C158	4030006710	S.CERAMIC C1808 SL 1H 470J-T-A
C159	4030006710	S.CERAMIC C1808 SL 1H 470J-T-A
C160	4030006710	S.CERAMIC C1808 SL 1H 470J-T-A
C161	4030006710	S.CERAMIC C1808 SL 1H 470J-T-A
C162	4030006710	S.CERAMIC C1808 SL 1H 470J-T-A
C163	4030006710	S.CERAMIC C1808 SL 1H 470J-T-A
C164	4030006710	S.CERAMIC C1808 SL 1H 470J-T-A
C166	4030006710	S.CERAMIC C1808 SL 1H 470J-T-A
C167	4030006710	S.CERAMIC C1808 SL 1H 470J-T-A
C168	4030006710	S.CERAMIC C1808 SL 1H 470J-T-A
C169	4030006710	S.CERAMIC C1808 SL 1H 470J-T-A
C170	4030006710	S.CERAMIC C1808 SL 1H 470J-T-A
C171	4030006710	S.CERAMIC C1808 SL 1H 470J-T-A
C172	4030006710	S.CERAMIC C1808 SL 1H 470J-T-A
C173	4030006710	S.CERAMIC C1808 SL 1H 470J-T-A
C180	4510004630	S.ELECTRO-LITIC ECEV1CA100R
C181	4510004590	ELECTROLITIC 18 MV 470 HC
C182	4030006860	S.CERAMIC C1808 JB 1H 102K-T-A
C183	4510005370	S.ELECTRO-LITIC ECEV1AA221P
C184	4030008760	S.CERAMIC C2012 X7R 1C 104K-T-A
C185	4030006540	S.CERAMIC C1808 SL 1H 030C-T-A
C186	4030006540	S.CERAMIC C1808 SL 1H 030C-T-A
C187	4030006710	S.CERAMIC C1808 SL 1H 470J-T-A
C189	4030006850	S.CERAMIC C1808 JB 1H 471K-T-A
C190	4030006850	S.CERAMIC C1808 JB 1H 471K-T-A
C191	4030006900	S.CERAMIC C1808 JB 1E 103K-T-A
C192	4030006850	S.CERAMIC C1808 JB 1H 471K-T-A
C205	4550004060	S.TANTALUM F95 0J106MSAAQ2
C206	4030006710	S.CERAMIC C1808 SL 1H 470J-T-A
C207	4030006860	S.CERAMIC C1808 JB 1H 102K-T-A
C210	4030006830	S.CERAMIC C1808 JF 1C 104Z-T-A
C211	4030006850	S.CERAMIC C1808 JB 1H 471K-T-A
C212	4030006860	S.CERAMIC C1808 JB 1H 102K-T-A
C213	4030006550	S.CERAMIC C1808 SL 1H 040C-T-A
C220	4030006710	S.CERAMIC C1808 SL 1H 470J-T-A
C221	4030006900	S.CERAMIC C1808 JB 1E 103K-T-A
C222	4030006860	S.CERAMIC C1808 JB 1H 102K-T-A
C223	4030006550	S.CERAMIC C1808 SL 1H 040C-T-A
C224	4030006560	S.CERAMIC C1808 SL 1H 050C-T-A
C225	4030006530	S.CERAMIC C1808 SL 1H 020C-T-A
C226	4030006530	S.CERAMIC C1808 SL 1H 020C-T-A
C227	4030006520	S.CERAMIC C1808 SL 1H 010C-T-A
C229	4030006900	S.CERAMIC C1808 JB 1E 103K-T-A
C231	4550004060	S.TANTALUM F95 0J106MSAAQ2
C232	4030006700	S.CERAMIC C1808 SL 1H 390J-T-A
C235	4030006700	S.CERAMIC C1808 SL 1H 390J-T-A
C237	4030006860	S.CERAMIC C1808 JB 1H 102K-T-A
C238	4030006860	S.CERAMIC C1808 JB 1H 102K-T-A
C239	4030006860	S.CERAMIC C1808 JB 1H 102K-T-A
C240	4550004230	S.TANTALUM F95 1A106MTAAQ2
C241	4030006850	S.CERAMIC C1808 JB 1H 471K-T-A
C242	4030007020	S.CERAMIC C1808 CH 1H 120J-T-A
C243	4550004060	S.TANTALUM F95 0J106MSAAQ2
C244	4030006830	S.CERAMIC C1808 JF 1C 104Z-T-A
C245	4030006860	S.CERAMIC C1808 JB 1H 102K-T-A
C246	4030006850	S.CERAMIC C1808 JB 1H 471K-T-A
C247	4030006850	S.CERAMIC C1808 JB 1H 471K-T-A
C248	4030006880	S.CERAMIC C1808 JB 1H 472K-T-A
C249	4030006850	S.CERAMIC C1808 JB 1H 471K-T-A
C250	4030006880	S.CERAMIC C1808 JB 1H 472K-T-A
C251	4030006850	S.CERAMIC C1808 JB 1H 471K-T-A
C252	4030006860	S.CERAMIC C1808 JB 1H 102K-T-A
C253	4030006540	S.CERAMIC C1808 SL 1H 030C-T-A
C254	4030006760	S.CERAMIC C1808 SL 1H 121J-T-A
C255	4030006710	S.CERAMIC C1808 SL 1H 470J-T-A
C256	4030006830	S.CERAMIC C1808 JF 1C 104Z-T-A
C257	4030006530	S.CERAMIC C1808 SL 1H 020C-T-A
C258	4030006530	S.CERAMIC C1808 SL 1H 020C-T-A
C259	4030006860	S.CERAMIC C1808 JB 1H 102K-T-A
C260	4030006860	S.CERAMIC C1808 JB 1H 102K-T-A
C261	4030006860	S.CERAMIC C1808 JB 1H 102K-T-A
C262	4030006860	S.CERAMIC C1808 JB 1H 102K-T-A
C263	4030006860	S.CERAMIC C1808 JB 1H 102K-T-A

[MAIN-C UNIT]

REF. NO.	ORDER NO.	DESCRIPTION
C264	4030006860	S.CERAMIC C1808 JB 1H 102K-T-A
C265	4030006860	S.CERAMIC C1808 JB 1H 102K-T-A
C266	4030006860	S.CERAMIC C1808 JB 1H 102K-T-A
C267	4030006860	S.CERAMIC C1808 JB 1H 102K-T-A
C268	4030006860	S.CERAMIC C1808 JB 1H 102K-T-A
C269	4030006860	S.CERAMIC C1808 JB 1H 102K-T-A
C270	4030006860	S.CERAMIC C1808 JB 1H 102K-T-A
C271	4030006860	S.CERAMIC C1808 JB 1H 102K-T-A
C272	4030006860	S.CERAMIC C1808 JB 1H 102K-T-A
C273	4030006860	S.CERAMIC C1808 JB 1H 102K-T-A
C274	4030006860	S.CERAMIC C1808 JB 1H 102K-T-A
C275	4030006860	S.CERAMIC C1808 JB 1H 102K-T-A
C276	4030006860	S.CERAMIC C1808 JB 1H 102K-T-A
C277	4030006860	S.CERAMIC C1808 JB 1H 102K-T-A
C278	4030006860	S.CERAMIC C1808 JB 1H 102K-T-A
C279	4030006860	S.CERAMIC C1808 JB 1H 102K-T-A
C280	4030006860	S.CERAMIC C1808 JB 1H 102K-T-A
C281	4030006700	S.CERAMIC C1808 SL 1H 390J-T-A
C282	4030006700	S.CERAMIC C1808 SL 1H 390J-T-A
C283	4030008760	S.CERAMIC C2012 X7R 1C 104K-T-A
C284	4030008440	S.CERAMIC C1808 SL 1H 1R5C-T-A
C285	4030006860	S.CERAMIC C1808 JB 1H 102K-T-A
C286	4030006710	S.CERAMIC C1808 SL 1H 470J-T-A
W1	7030003970	S.JUMPER MCR18EZHZ JPW (000)
W2	7030003860	S.JUMPER ERJ3GE JPW V
W4	7030003970	S.JUMPER MCR18EZHZ JPW (000)
W6	7030003860	S.JUMPER ERJ3GE JPW V
W8	7030003860	S.JUMPER ERJ3GE JPW V
W11	7030003860	S.JUMPER ERJ3GE JPW V
W12	7410000760	S.JUMPER EXB-V4V JPWV
W14	7030003860	S.JUMPER ERJ3GE JPW V
W15	7030003860	S.JUMPER ERJ3GE JPW V
W16	7030003860	S.JUMPER ERJ3GE JPW V
W17	7030003860	S.JUMPER ERJ3GE JPW V
W18	7030003860	S.JUMPER ERJ3GE JPW V
W19	7030003860	S.JUMPER ERJ3GE JPW V
W25	8900001980	CABLE OPC-188 [1200 MHz ANT]
W28	8900004520	CABLE OPC-373A
W30	7030003860	S.JUMPER ERJ3GE JPW V
W31	7030003860	S.JUMPER ERJ3GE JPW V
W32	7030003860	S.JUMPER ERJ3GE JPW V
W33	7030003860	S.JUMPER ERJ3GE JPW V
W34	7030003860	S.JUMPER ERJ3GE JPW V
W35	7030003860	S.JUMPER ERJ3GE JPW V
W37	7030003860	S.JUMPER ERJ3GE JPW V
W39	7030000010	S.JUMPER MCR10EZHZ JPW (000)
W40	7030003860	S.JUMPER ERJ3GE JPW V
W41	7030003970	S.JUMPER MCR18EZHZ JPW (000)
W42	7030003860	S.JUMPER ERJ3GE JPW V
W43	7120000380	JUMPER JPW 01 R-01
W44	7120000380	JUMPER JPW 01 R-01
W45	7120000380	JUMPER JPW 01 R-01
J1	6510014710	CONNECTOR 52330-1017
J2	6510014710	CONNECTOR 52330-1017
J5	6450001330	CONNECTOR HSJ1332-01-020 [1200 MHz SP]
J6	6510014960	S.CONNECTOR B2B-ZR-SM3-TF
EP1	0910036535	PCB B 3550E
WS1	8970020460	== 0.8D coaxial cable (1)/MA-C
MP1	8930005320	SPACER Filter spacer
MP2	8930005320	SPACER Filter spacer
MP3	8930024850	TERMINAL 1126 terminal
MP4	8950003290	SHEET Glass sticker
MP5	8510008480	PLATE 1128 LO shield plate
MP6	8930000680	SPACER Spacer with screw (R)
MP7	8810003960	SCREW Setscrew A M2.8 x 5

S.=Surface mount

[MAIN-C UNIT]

REF. NO.	ORDER NO.	DESCRIPTION	
MP10	8950001920	SHEET	Firamen sticker 9510
MP11	8930001180	SPRING	Ground contact FX22
MP12	8930001180	SPRING	Ground contact FX22
MP13	8510008460	PLATE	1128 LO-B plate
MP14	89300032400	SPONGE	1352 I-sponge

[PLL-C BOARD]

REF. NO.	ORDER NO.	DESCRIPTION	
IC1	1140002130	S.IC	MB1511PFV-G-BND
Q1	1530002920	S.TRANSISTOR	2SC4226-T2 R25
Q2	1580000490	S.FET	2SK508 K52 T2B
Q3	1530002920	S.TRANSISTOR	2SC4226-T2 R25
Q6	1510000830	S.TRANSISTOR	2SA1587-GR (TE85R)
Q7	1530003010	S.TRANSISTOR	2SC4117-GR (TE85R)
Q8	1580000530	S.FET	2SK880-GR (TE85R)
Q9	1590001190	S.TRANSISTOR	XP8501-(TX).AB
D1	1720000460	S.VARICAP	1SV187-T1
D2	1720000460	S.VARICAP	1SV187-T1
D3	1750000260	S.DIODE	1SS352 (TPH3)
D5	1790000980	S.DIODE	MA742(TX)
L1	8200002560	S.COIL	NL 252018T-018K
L2	8200001570	S.COIL	LER 015T 1R0M
L3	8200001570	S.COIL	LER 015T 1R0M
L4	8200002410	S.COIL	NL 252018T-056J
L5	8200002700	S.COIL	LER 015T R47M
L6	8200001550	S.COIL	LER 015T R58M
L7	8200002580	S.COIL	NL 252018T-018K
L8	8200002190	S.COIL	MLF2012A 4R7K-T
L9	8200001350	S.COIL	MLF2012E 100M-T
R1	7030003280	S.RESISTOR	ERJ3GEYJ 470 V (47 Ω)
R2	7030003520	S.RESISTOR	ERJ3GEYJ 472 V (4.7 kΩ)
R3	7030003420	S.RESISTOR	ERJ3GEYJ 881 V (880 Ω)
R4	7030003280	S.RESISTOR	ERJ3GEYJ 470 V (47 Ω)
R5	7030003280	S.RESISTOR	ERJ3GEYJ 470 V (47 Ω)
R6	7030003280	S.RESISTOR	ERJ3GEYJ 470 V (47 Ω)
R10	7030003320	S.RESISTOR	ERJ3GEYJ 101 V (100 Ω)
R11	7030003520	S.RESISTOR	ERJ3GEYJ 472 V (4.7 kΩ)
R12	7030003440	S.RESISTOR	ERJ3GEYJ 102 V (1 kΩ)
R13	7030003240	S.RESISTOR	ERJ3GEYJ 220 V (22 Ω)
R20	7030003640	S.RESISTOR	ERJ3GEYJ 473 V (47 kΩ)
R21	7030003640	S.RESISTOR	ERJ3GEYJ 473 V (47 kΩ)
R22	7030003640	S.RESISTOR	ERJ3GEYJ 473 V (47 kΩ)
R26	7030003570	S.RESISTOR	ERJ3GEYJ 123 V (12 kΩ)
R27	7030003530	S.RESISTOR	ERJ3GEYJ 582 V (5.8 kΩ)
R28	7030003530	S.RESISTOR	ERJ3GEYJ 582 V (5.8 kΩ)
R29	7030003570	S.RESISTOR	ERJ3GEYJ 123 V (12 kΩ)
R32	7030003600	S.RESISTOR	ERJ3GEYJ 223 V (22 kΩ)
R33	7030003430	S.RESISTOR	ERJ3GEYJ 821 V (820 Ω)
R34	7030003610	S.RESISTOR	ERJ3GEYJ 273 V (27 kΩ)
R35	7030003480	S.RESISTOR	ERJ3GEYJ 222 V (2.2 kΩ)
R36	7030003320	S.RESISTOR	ERJ3GEYJ 101 V (100 Ω)
R37	7030003450	S.RESISTOR	ERJ3GEYJ 122 V (1.2 kΩ)
R38	7030003410	S.RESISTOR	ERJ3GEYJ 561 V (560 Ω)
R39	7030003380	S.RESISTOR	ERJ3GEYJ 221 V (220 Ω)
R40	7030003480	S.RESISTOR	ERJ3GEYJ 152 V (1.5 kΩ)
R41	7030003520	S.RESISTOR	ERJ3GEYJ 472 V (4.7 kΩ)
R42	7030003400	S.RESISTOR	ERJ3GEYJ 471 V (470 Ω)
R43	7030003520	S.RESISTOR	ERJ3GEYJ 472 V (4.7 kΩ)

[PLL-C BOARD]

REF. NO.	ORDER NO.	DESCRIPTION	
C1	4030008630	S.CERAMIC	C1608 SL 1H 150J-T-A
C2	4030008660	S.CERAMIC	C1608 JB 1H 102K-T-A
C3	4030008650	S.CERAMIC	C1608 JB 1H 471K-T-A
C4	4030009570	S.CERAMIC	C1608 CH 1H 0R3B-T-A
C6	4550004090	S.TANTALUM	F95 1A475MRAAQ2
C7	4030008950	S.CERAMIC	C1608 CH 1H 040C-T-A
C8	4030008660	S.CERAMIC	C1608 JB 1H 102K-T-A
C9	4030008650	S.CERAMIC	C1608 JB 1H 471K-T-A
C11	4030008660	S.CERAMIC	C1608 JB 1H 102K-T-A
C12	4030008660	S.CERAMIC	C1608 JB 1H 102K-T-A
C13	4030008650	S.CERAMIC	C1608 JB 1H 471K-T-A
C14	4030008630	S.CERAMIC	C1608 SL 1H 150J-T-A
C15	4030008650	S.CERAMIC	C1608 JB 1H 471K-T-A
C17	4030008660	S.CERAMIC	C1608 JB 1H 102K-T-A
C19	4030008660	S.CERAMIC	C1608 JB 1H 102K-T-A
C20	4030008660	S.CERAMIC	C1608 JB 1H 102K-T-A
C21	4030008660	S.CERAMIC	C1608 JB 1H 102K-T-A
C24	4030008900	S.CERAMIC	C1608 JB 1E 103K-T-A
C25	4030008710	S.CERAMIC	C1608 SL 1H 470J-T-A
C30	4550004130	S.TANTALUM	F95 1C335MSAAQ2
C31	4030008660	S.CERAMIC	C1608 JB 1H 102K-T-A
C32	4030008900	S.CERAMIC	C1608 JB 1E 103K-T-A
C33	4030008660	S.CERAMIC	C1608 JB 1H 102K-T-A
C34	4030008760	S.CERAMIC	C2012 X7R 1C 104K-T-A
C35	4550008060	S.TANTALUM	TEMSVB2 1C 885M8L
C36	4550008060	S.TANTALUM	TEMSVB2 1C 885M8L
C37	4030008660	S.CERAMIC	C1608 JB 1H 102K-T-A
C38	4030008910	S.CERAMIC	C1608 CH 1H 0R5C-T-A
C39	4550000530	S.TANTALUM	TESVA 1V 104M1-8L
EP1	0910037793	PCB	B 3741C
EP2	8510008580	LEADFRAM	PT2.0-0.7-16.5 (K)
MP1	8510007670	CASE	1128 VCO case
MP2	8510008070	PLATE	1128 VCO plate
MP3	8930027970	SHEET	Insulating sheet CQ

[VCO-C BOARD]

REF. NO.	ORDER NO.	DESCRIPTION	
Q1	1580000490	S.FET	2SK508 K52 T2B
Q2	1530002920	S.TRANSISTOR	2SC4226-T2 R25
D1	1720000440	S.VARICAP	1T362A-08-T8B
D2	1720000440	S.VARICAP	1T362A-08-T8B
D3	1720000440	S.VARICAP	1T362A-08-T8B
D4	1720000440	S.VARICAP	1T362A-08-T8B
D5	1790000620	S.DIODE	MA77 (TW)
L1	8200001570	S.COIL	LER 015T 1R0M
L2	8200002270	S.COIL	LQP31A 22NG04
L3	8200001570	S.COIL	LER 015T 1R0M
L4	8200001570	S.COIL	LER 015T 1R0M
L5	8200002560	S.COIL	NL 252018T-018K
L6	8200001570	S.COIL	LER 015T 1R0M
R2	7030003560	S.RESISTOR	ERJ3GEYJ 103 V (10 kΩ)
R4	7030003240	S.RESISTOR	ERJ3GEYJ 220 V (22 Ω)
R6	7030003240	S.RESISTOR	ERJ3GEYJ 220 V (22 Ω)
R7	7030003360	S.RESISTOR	ERJ3GEYJ 221 V (220 Ω)
R8	7030003520	S.RESISTOR	ERJ3GEYJ 472 V (4.7 kΩ)
R10	7030003480	S.RESISTOR	ERJ3GEYJ 152 V (1.5 kΩ)
R11	7030003440	S.RESISTOR	ERJ3GEYJ 102 V (1 kΩ)
R12	7030003440	S.RESISTOR	ERJ3GEYJ 102 V (1 kΩ)
R13	7030003220	S.RESISTOR	ERJ3GEYJ 150 V (15 Ω)

S.=Surface mount

[AFC-C BOARD]

REF. NO.	ORDER NO.	DESCRIPTION	
C1	4550000530	S.TANTALUM	TESVA 1V 104M1-8L
C3	4030006710	S.CERAMIC	C1608 SL 1H 470J-T-A
C5	4550004220	S.TANTALUM	F951A885MSAAQ2
C6	4030006850	S.CERAMIC	C1608 JB 1H 471K-T-A
C7	4030006920	S.CERAMIC	C1608 CH 1H 010C-T-A
C9	4030006850	S.CERAMIC	C1608 JB 1H 471K-T-A
C10	4030006850	S.CERAMIC	C1608 JB 1H 471K-T-A
C11	4030006910	S.CERAMIC	C1608 CH 1H 0R5C-T-A
C12	4030006860	S.CERAMIC	C1608 JB 1H 102K-T-A
C13	4030006850	S.CERAMIC	C1608 JB 1H 471K-T-A
C14	4030006570	S.CERAMIC	C1608 SL 1H 060D-T-A
C15	4030006880	S.CERAMIC	C1608 JB 1H 102K-T-A
C19	4030006860	S.CERAMIC	C1608 JB 1H 102K-T-A
C20	4030006710	S.CERAMIC	C1608 SL 1H 470J-T-A
C21	4030006860	S.CERAMIC	C1608 JB 1H 102K-T-A
C22	4030006860	S.CERAMIC	C1608 JB 1H 102K-T-A
C23	4030006860	S.CERAMIC	C1608 JB 1H 102K-T-A
W1	7030003860	S.JUMPER	ERJ3GE JPW V
W3	7030000010	S.JUMPER	MCR10EZHZ JPW (000)
EP1	0910035853	PCB	B 3552C
EP2	6510008580	LEADFRAM	PT2.0-0.7-16.5 (K)

[YGR-C BOARD]

REF. NO.	ORDER NO.	DESCRIPTION	
Q1	1530002400	S.TRANSISTOR	2SC4093 R27 T2B
Q2	1530002680	S.TRANSISTOR	2SC3357-T2
Q3	1530002680	S.TRANSISTOR	2SC3357-T2
D1	1750000050	S.DIODE	1SS193 (TE85R)
R1	7030003520	S.RESISTOR	ERJ3GEYJ 472 V (4.7 kΩ)
R2	7030003600	S.RESISTOR	ERJ3GEYJ 223 V (22 kΩ)
R3	7030003200	S.RESISTOR	ERJ3GEYJ 100 V (10 Ω)
R5	7030003300	S.RESISTOR	ERJ3GEYJ 680 V (68 Ω)
R6	7030000140	S.RESISTOR	MCR10EZHZ 10 Ω (100)
R7	7030003440	S.RESISTOR	ERJ3GEYJ 102 V (1 kΩ)
R8	7030003540	S.RESISTOR	ERJ3GEYJ 682 V (6.8 kΩ)
R9	7030000110	S.RESISTOR	MCR10EZHZ 5.6 Ω (5R6)
R10	7030003520	S.RESISTOR	ERJ3GEYJ 472 V (4.7 kΩ)
C1	4030006860	S.CERAMIC	C1608 JB 1H 102K-T-A
C2	4030009540	S.CERAMIC	C1608 CH 1H 1R5B-T-A
C4	4030006850	S.CERAMIC	C1608 JB 1H 471K-T-A
C5	4030006710	S.CERAMIC	C1608 SL 1H 470J-T-A
C6	4030006710	S.CERAMIC	C1608 SL 1H 470J-T-A
C7	4030006850	S.CERAMIC	C1608 JB 1H 471K-T-A
C8	4030009540	S.CERAMIC	C1608 CH 1H 1R5B-T-A
C10	4030006710	S.CERAMIC	C1608 SL 1H 470J-T-A
C11	4030006850	S.CERAMIC	C1608 JB 1H 471K-T-A
C12	4030006940	S.CERAMIC	C1608 CH 1H 030C-T-A
C14	4030006710	S.CERAMIC	C1608 SL 1H 470J-T-A
C15	4030006850	S.CERAMIC	C1608 JB 1H 471K-T-A
C16	4030006860	S.CERAMIC	C1608 JB 1H 102K-T-A
EP1	0910036682	PCB	B 3555B
EP2	6910003110	LEADFRAM	HFB2.0-0.7-8 (N)

[DRIVER-C BOARD]

REF. NO.	ORDER NO.	DESCRIPTION	
Q1	1530003080	TRANSISTOR	2SC3814
R1	7030003340	S.RESISTOR	ERJ3GEYJ 151 V (150 Ω)
C1	4030009540	S.CERAMIC	C1608 CH 1H 1R5B-T-A
C2	4030006710	S.CERAMIC	C1608 SL 1H 470J-T-A
C4	4030006940	S.CERAMIC	C1608 CH 1H 030C-T-A
EP1	0910036111	PCB	B 3558A
EP2	6910003110	LEADFRAM	HFB2.0-0.7-8 (N)
MP1	8410001830	HEATSINK	1126 driver heatsink

[APC-C BOARD]

REF. NO.	ORDER NO.	DESCRIPTION	
IC1	1110003340	S.IC	μPC358GR-T1
Q1	1530002280	S.TRANSISTOR	2SC4081 T107 S
Q2	1590000430	S.TRANSISTOR	DTC144EU T107
D1	1790001000	S.ZENER	MA8062-L (TX)
R1	7030003560	S.RESISTOR	ERJ3GEYJ 103 V (10 kΩ)
R2	7030003640	S.RESISTOR	ERJ3GEYJ 473 V (47 kΩ)
R3	7030003560	S.RESISTOR	ERJ3GEYJ 103 V (10 kΩ)
R4	7030003320	S.RESISTOR	ERJ3GEYJ 101 V (100 Ω)
R5	7030003840	S.RESISTOR	ERJ3GEYJ 225 V (2.2 MΩ)
R6	7030003650	S.RESISTOR	ERJ3GEYJ 563 V (56 kΩ)
R7	7030003580	S.RESISTOR	ERJ3GEYJ 153 V (15 kΩ)
R8	7030003660	S.RESISTOR	ERJ3GEYJ 683 V (68 kΩ)
R9	7030003470	S.RESISTOR	ERJ3GEYJ 182 V (1.8 kΩ)
R10	7030003690	S.RESISTOR	ERJ3GEYJ 124 V (120 kΩ)
R11	7030003640	S.RESISTOR	ERJ3GEYJ 473 V (47 kΩ)
R12	7030003640	S.RESISTOR	ERJ3GEYJ 473 V (47 kΩ)
C1	4030006850	S.CERAMIC	C1608 JB 1H 471K-T-A
C2	4550004230	S.TANTALUM	F95 1A106MTAAQ2
C3	4030006850	S.CERAMIC	C1608 JB 1H 471K-T-A
C4	4030006850	S.CERAMIC	C1608 JB 1H 471K-T-A
C5	4030006850	S.CERAMIC	C1608 JB 1H 471K-T-A
C6	4030006850	S.CERAMIC	C1608 JB 1H 471K-T-A
C7	4030006850	S.CERAMIC	C1608 JB 1H 471K-T-A
C8	4030006850	S.CERAMIC	C1608 JB 1H 471K-T-A
EP1	0910036692	PCB	B 3554B
EP2	6910003110	LEADFRAM	HFB2.0-0.7-8 (N)

[IF-C BOARD]

REF. NO.	ORDER NO.	DESCRIPTION	
IC1	1110002780	S.IC	MC3371DR
IC2	1110002750	S.IC	TA75S01F (TE85R)
IC3	1110000960	S.IC	NJM4558M (T1)
D1	1790000980	S.DIODE	MA742 (TX)

S.=Surface mount

[IF-C BOARD]

REF. NO.	ORDER NO.	DESCRIPTION	
R1	7030003760	S.RESISTOR	ERJ3GEYJ 474 V (470 kΩ)
R2	7030003520	S.RESISTOR	ERJ3GEYJ 472 V (4.7 kΩ)
R5	7030003480	S.RESISTOR	ERJ3GEYJ 222 V (2.2 kΩ)
R6	7030003400	S.RESISTOR	ERJ3GEYJ 471 V (470 Ω)
R7	7030003680	S.RESISTOR	ERJ3GEYJ 104 V (100 kΩ)
R10	7030003660	S.RESISTOR	ERJ3GEYJ 683 V (68 kΩ)
R11	7030003800	S.RESISTOR	ERJ3GEYJ 105 V (1 MΩ)
R14	7030003560	S.RESISTOR	ERJ3GEYJ 103 V (10 kΩ)
R15	7030003570	S.RESISTOR	ERJ3GEYJ 123 V (12 kΩ)
R16	7030003830	S.RESISTOR	ERJ3GEYJ 185 V (1.8 MΩ)
R18	7030003600	S.RESISTOR	ERJ3GEYJ 223 V (22 kΩ)
R19	7030003510	S.RESISTOR	ERJ3GEYJ 392 V (3.9 kΩ)
R20	7030003800	S.RESISTOR	ERJ3GEYJ 105 V (1 MΩ)
R21	7030003810	S.RESISTOR	ERJ3GEYJ 125 V (1.2 MΩ)
R22	7030003630	S.RESISTOR	ERJ3GEYJ 393 V (39 kΩ)
R23	7030003630	S.RESISTOR	ERJ3GEYJ 393 V (39 kΩ)
R24	7030003630	S.RESISTOR	ERJ3GEYJ 393 V (39 kΩ)
C1	4030006900	S.CERAMIC	C1608 JB 1E 103K-T-A
C2	4030006860	S.CERAMIC	C1608 JB 1H 102K-T-A
C3	4030006890	S.CERAMIC	C1608 SL 1H 330J-T-A
C4	4030006860	S.CERAMIC	C1608 JB 1H 102K-T-A
C5	4030006880	S.CERAMIC	C1608 JB 1H 102K-T-A
C6	4030006850	S.CERAMIC	C1608 JB 1H 471K-T-A
C7	4030006850	S.CERAMIC	C1608 JB 1H 471K-T-A
C9	4030006900	S.CERAMIC	C1608 JB 1E 103K-T-A
C10	4550004700	S.TANTALUM	F95 1V474MQAAQ2
C11	4030006900	S.CERAMIC	C1608 JB 1E 103K-T-A
C13	4030009580	S.CERAMIC	C1608 JB 1H 681K-T-A
C14	4030006900	S.CERAMIC	C1608 JB 1E 103K-T-A
C15	4030006900	S.CERAMIC	C1608 JB 1E 103K-T-A
C16	4030006900	S.CERAMIC	C1608 JB 1E 103K-T-A
C17	4030006470	S.CERAMIC	C2012 JB 1H 153K-T-A
C18	4030006630	S.CERAMIC	C1608 JF 1C 104Z-T-A
C19	4030006630	S.CERAMIC	C1608 JF 1C 104Z-T-A
C25	4030006630	S.CERAMIC	C1608 JF 1C 104Z-T-A
C26	4030006630	S.CERAMIC	C1608 JF 1C 104Z-T-A
C27	4030006870	S.CERAMIC	C1608 JB 1H 222K-T-A
C28	4030006830	S.CERAMIC	C1608 SL 1H 331J-T-A
C29	4030006880	S.CERAMIC	C1608 JB 1H 472K-T-A
EP1	0910037211	PCB	B 3553A
EP2	6910003110	LEADFRAM	HFB2.0-0.7-8 (N)

[RFT-C BOARD]

REF. NO.	ORDER NO.	DESCRIPTION	
C1	4030006540	S.CERAMIC	C1608 SL 1H 030C-T-A
C2	4030006540	S.CERAMIC	C1608 SL 1H 030C-T-A
C3	4030006540	S.CERAMIC	C1608 SL 1H 030C-T-A
C4	4030006860	S.CERAMIC	C1608 JB 1H 102K-T-A
C5	4030006550	S.CERAMIC	C1608 SL 1H 040C-T-A
C6	4030006550	S.CERAMIC	C1608 SL 1H 040C-T-A
C7	4030006700	S.CERAMIC	C1608 SL 1H 390J-T-A
C8	4030006860	S.CERAMIC	C1608 JB 1H 102K-T-A
C9	4030006530	S.CERAMIC	C1608 SL 1H 020C-T-A
C10	4030006860	S.CERAMIC	C1608 JB 1H 102K-T-A
C11	4030006860	S.CERAMIC	C1608 JB 1H 102K-T-A
C12	4030006610	S.CERAMIC	C1608 SL 1H 100D-T-A
EP1	0910036012	PCB	B 3556B
EP2	6910003110	LEADFRAM	HFB2.0-0.7-8 (N)

[AFC-C BOARD]

REF. NO.	ORDER NO.	DESCRIPTION	
IC1	1130005810	S.IC	BU4094BF-T1
R1	7030003810	S.RESISTOR	ERJ3GEYJ 125 V (1.2 MΩ)
R2	7030003780	S.RESISTOR	ERJ3GEYJ 684 V (680 kΩ)
R3	7030003740	S.RESISTOR	ERJ3GEYJ 334 V (330 kΩ)
R4	7030003700	S.RESISTOR	ERJ3GEYJ 154 V (150 kΩ)
R5	7030003670	S.RESISTOR	ERJ3GEYJ 823 V (82 kΩ)
R6	7030003630	S.RESISTOR	ERJ3GEYJ 393 V (39 kΩ)
R7	7030003600	S.RESISTOR	ERJ3GEYJ 223 V (22 kΩ)
R8	7030003560	S.RESISTOR	ERJ3GEYJ 103 V (10 kΩ)
C1	4030006900	S.CERAMIC	C1608 JB 1E 103K-T-A
C2	4030006860	S.CERAMIC	C1608 JB 1H 102K-T-A
EP1	0910035901	PCB	B 3557A
EP2	6910003110	LEADFRAM	HFB2.0-0.7-8 (N)

[RFT-C BOARD]

REF. NO.	ORDER NO.	DESCRIPTION	
Q1	1530002940	S.TRANSISTOR	2SC4228-T2 R44
Q2	1580000360	S.FET	3SK177-T2B U73
Q3	1590001470	S.TRANSISTOR	UN9213(TX)
Q4	1530002900	S.TRANSISTOR	2SC4228-T2 R5
D1	1790000620	S.DIODE	MA77(TW)
L1	6200002550	S.COIL	NL 252018T-010K
R1	7030003540	S.RESISTOR	ERJ3GEYJ 682 V (6.8 kΩ)
R2	7030003600	S.RESISTOR	ERJ3GEYJ 223 V (22 kΩ)
R3	7030003360	S.RESISTOR	ERJ3GEYJ 221 V (220 Ω)
R4	7030003560	S.RESISTOR	ERJ3GEYJ 103 V (10 kΩ)
R5	7030003340	S.RESISTOR	ERJ3GEYJ 151 V (150 Ω)
R6	7030003560	S.RESISTOR	ERJ3GEYJ 103 V (10 kΩ)
R7	7030003310	S.RESISTOR	ERJ3GEYJ 820 V (82 Ω)
R8	7030003440	S.RESISTOR	ERJ3GEYJ 102 V (1 kΩ)
R9	7030003560	S.RESISTOR	ERJ3GEYJ 103 V (10 kΩ)
R10	7030003440	S.RESISTOR	ERJ3GEYJ 102 V (1 kΩ)

[CHASSIS-A PART]

REF. NO.	ORDER NO.	DESCRIPTION	
MP1	8010015260	CHASSIS	1354 chassis
MP2	8510008200	PLATE	1126 shield plate
MP4	8930024800	CLIP	1126 transistor clip
MP5	8310027570	PLATE	1126 module plate
MP6	8810003960	SCREW	Setscrew A M2.6 × 5
MP7	8810002110	SCREW	FH M2.6 × 5
MP8	8810007230	SCREW	Setscrew H M3 × 8
MP9	8810002750	SCREW	Screw M2.6 Black BS
MP10	8810007970	SCREW	PH BT M3 × 6 NI
MP11	6950000040	CAP	M-type cap (black)
MP12	8930028820	SHEET	Himeron sheet AJ

S.=Surface mount

[CHASSIS-B PART]

REF. NO.	ORDER NO.	DESCRIPTION	
MP1	8010015260	CHASSIS	1354 chassis
MP2	8510009120	PLATE	1126 B shield plate
MP4	8930027480	CLIP	1126 transistor-A clip
MP5	8310027570	PLATE	1126 module plate
MP6	8810003960	SCREW	Setscrew A M2.6 x 5
MP7	8810002110	SCREW	FH M2.6 x 5
MP8	8810007230	SCREW	Setscrew H M3 x 8
MP9	8810002750	SCREW	BuH M2.6 x 6 black BS
MP10	8810007970	SCREW	PH BTM3 x 6 NI
MP11	6950000030	CAP	N-type cap-1
MP12	8930028530	PLATE	1126 B-module cover
MP13	8010012750	COVER	1126 bush

[CHASSIS PART]

REF. NO.	ORDER NO.	DESCRIPTION	
MP1	8930024840	PLATE	1126 terminal plate
MP2	8810007130	SCREW	Setscrew H M3 x 6
MP3	8930024790	PIPE	Pipe (F)
MP4	8810007330	SCREW	PH M3 x 40
MP5	8830000100	SCREW	Nut M 3
MP6	8810006230	SCREW	OH M2.6 x 4 ZK
MP7	8810007430	SCREW	BuH M2.6 x 4 ZK
MP8	8810006230	SCREW	OH M2.6 x 4 ZK
MP9	8810002110	SCREW	FH M2.6 x 5
MP10	8810006530	SCREW	OH M2.6 x 6 ZK BS

[CHASSIS-C PART]

REF. NO.	ORDER NO.	DESCRIPTION	
MP1	8010015260	CHASSIS	1354 chassis
MP2	8510008290	PLATE	1126 C shield plate
MP3	8010012750	COVER	1126 bush
MP4	8930027480	CLIP	1126 transistor-A clip
MP5	8310027570	PLATE	1126 module plate
MP6	8810003960	SCREW	Setscrew A M2.6 x 5
MP7	8810002110	SCREW	FH M2.6 x 5
MP8	8810007230	SCREW	Setscrew H M3 x 8
MP9	8810002750	SCREW	BuH M2.6 x 6 black BS
MP10	8810001410	SCREW	PH B1 M3 x 6 NI
MP11	6950000030	CAP	N-type cap-1
MP12	8310030190	PLATE	1126 module cover
MP13	8810002110	SCREW	FH M2.6 x 5

[COVER PART]

REF. NO.	ORDER NO.	DESCRIPTION	
MF1	2710000410	FAN	0410-12H
MP1	8110004800	COVER	1126 top cover
MP2	8110004790	COVER	1126 bottom cover
MP3	8510008350	COVER	1128 fan cover
MP4	8930029350	ANGLE	1128 fan angle
MP6	8810007260	SCREW	OH M2.6 x 14 ZK

[UNPACKING]

REF. NO.	ORDER NO.	DESCRIPTION	
F1	5210000080	FUSE	FGB 20A
MC1	7700001590	MICROPHONE	HM-88A (USA)
MC1	7700001580	MICROPHONE	HM-88 (EUR, AUS, SEA)
W1	8900003760	CABLE	OPC-346
MP1	8010005181	M.B.	Mounting bracket (B)-1 black
MP2	8930008050	SPONGE	Felt (A)
MP3	8820000530	SCREW	Frang bolt
MP4	8810000470	SCREW	PH M5 x 12 (+ -)
MP5	8810000950	SCREW	PH A M5 x 16
MP6	8850000150	WASHER	Flat washer M5 NI BS
MP7	8850000390	WASHER	Spring washer M5
MP8	8830000120	SCREW	Nut M5

[CHASSIS-D PART]

REF. NO.	ORDER NO.	DESCRIPTION	
SP1	2510000570	SPEAKER	T040S10A0000
WS1	8800031020	==	P01CH-D
MP1	8010012520	CHASSIS	1126 sub chassis
MP2	8930024870	BUTTON	1126 release button
MP3	8930024820	SPRING	1126 release spring
MP4	8930024831	PLATE	1126 release plate-1
MP5	8930024810	HOLDER	1126 speaker holder
MP7	8810000520	SCREW	PH No. 0 M2 x 4.5 black
MP8	8810003960	SCREW	Setscrew A M2.6 x 5
MP9	8810003960	SCREW	Setscrew A M2.6 x 5
MP10	8930026380	CLIP	1126 IC clip
MP11	8930027940	CLIP	1126 transistor-B clip
MP12	8930018530	SHEET	Himeron sheet X
MP13	8930028810	SHEET	Himeron sheet AI
MP14	8930028830	SHEET	Himeron sheet AK
MP15	8930028860	SPONGE	Sponge (DH)
MP16	8930030350	SHEET	1126 release sheet
MP17	8930030360	SHEET	Insulating sheet CY

S.=Surface mount      Screw abbreviation FH: Flat head      PH: Pan head      BuH: Button head      OH: Oval countersunk head

[HM-88/A MAIN BOARD]

REF. NO.	ORDER NO.	DESCRIPTION	
IC1	1110003100	S.IC	TA7330F (SO)
IC2	1180000850	S.IC	RH5RC501A-T1
Q2	1510000770	S.TRANSISTOR	2SA1586-GR (TE85R)
Q9	1590000880	S.TRANSISTOR	DTC114EU T107
Q11	1590001330	S.TRANSISTOR	DTA114EU T107
Q15	1510000770	S.TRANSISTOR	2SA1586-GR (TE85R)
Q16	1510000770	S.TRANSISTOR	2SA1586-GR (TE85R)
Q17	1510000770	S.TRANSISTOR	2SA1586-GR (TE85R)
Q21	1530002280	S.TRANSISTOR	2SC4081 T107 S
Q22	1530002050	S.TRANSISTOR	2SC3661-TA
Q23	1510000770	S.TRANSISTOR	2SA1586-GR (TE85R)
D1	1790000980	S.DIODE	MA742 (TX)
D4	1790000970	S.DIODE	MA729 (TX)
D12	1790000970	S.DIODE	MA729 (TX)
D14	1730002280	S.ZENER	MA8030-H (TX)
D16	1790000970	S.DIODE	MA729 (TX)
L4	6200000730	S.COIL	LQH 3N 2R2M
L9	6190000690	S.COIL	S152111
L10	6200000730	S.COIL	LQH 3N 2R2M
L11	6200000730	S.COIL	LQH 3N 2R2M
L11	6200000850	S.COIL	LQH 3N R10M
L12	6200000730	S.COIL	LQH 3N 2R2M
L14	6200000850	S.COIL	LQH 3N R10M
L15	6200000850	S.COIL	LQH 3N R10M
R1	7030003440	S.RESISTOR	ERJ3GEYJ 102 V (1 kΩ) (HM-88A)
R1	7030003520	S.RESISTOR	ERJ3GEYJ 472 V (4.7 kΩ) (HM-88)
R2	7030003440	S.RESISTOR	ERJ3GEYJ 102 V (1 kΩ)
R7	7030003630	S.RESISTOR	ERJ3GEYJ 393 V (39 kΩ)
R8	7030003550	S.RESISTOR	ERJ3GEYJ 822 V (8.2 kΩ)
R9	7030003800	S.RESISTOR	ERJ3GEYJ 105 V (1 MΩ)
R10	7030003490	S.RESISTOR	ERJ3GEYJ 272 V (2.7 kΩ)
R11	7030003350	S.RESISTOR	ERJ3GEYJ 181 V (180 Ω)
R12	7030003350	S.RESISTOR	ERJ3GEYJ 181 V (180 Ω)
R13	7030003760	S.RESISTOR	ERJ3GEYJ 474 V (470 kΩ)
R14	7030003480	S.RESISTOR	ERJ3GEYJ 222 V (2.2 kΩ)
R15	7030003800	S.RESISTOR	ERJ3GEYJ 105 V (1 MΩ)
R16	7030003620	S.RESISTOR	ERJ3GEYJ 333 V (33 kΩ)
R34	7030003570	S.RESISTOR	ERJ3GEYJ 123 V (12 kΩ)
R56	7030003580	S.RESISTOR	ERJ3GEYJ 103 V (10 kΩ)
R57	7030003330	S.RESISTOR	ERJ3GEYJ 121 V (120 Ω)
R58	7030003390	S.RESISTOR	ERJ3GEYJ 391 V (390 Ω)
R59	7030003560	S.RESISTOR	ERJ3GEYJ 103 V (10 kΩ)
R60	7030003640	S.RESISTOR	ERJ3GEYJ 473 V (47 kΩ)
R77	7030003530	S.RESISTOR	ERJ3GEYJ 562 V (5.6 kΩ)
R78	7030003620	S.RESISTOR	ERJ3GEYJ 333 V (33 kΩ)
R79	7030003620	S.RESISTOR	ERJ3GEYJ 333 V (33 kΩ)
R81	7030003410	S.RESISTOR	ERJ3GEYJ 561 V (560 Ω)
R84	7030003620	S.RESISTOR	ERJ3GEYJ 333 V (33 kΩ)
R85	7030003580	S.RESISTOR	ERJ3GEYJ 153 V (15 kΩ)
R86	7030003550	S.RESISTOR	ERJ3GEYJ 822 V (8.2 kΩ)
R87	7030003600	S.RESISTOR	ERJ3GEYJ 223 V (22 kΩ)
R88	7030003780	S.RESISTOR	ERJ3GEYJ 474 V (470 kΩ)
R96	7030003200	S.RESISTOR	ERJ3GEYJ 100 V (10 Ω)
C1	4550004200	S.TANTALUM	F95 1A225MQAAQ2
C2	4010000500	CERAMIC	DD104 B 102K 50V
C3	4030008630	S.CERAMIC	C1608 JF 1C 104Z-T-A
C4	4030008630	S.CERAMIC	C1608 JF 1C 104Z-T-A
C5	4030008630	S.CERAMIC	C1608 JB 1E 103K-T-A
C6	4030008630	S.CERAMIC	C1608 JB 1E 103K-T-A
C7	4030008630	S.CERAMIC	C1608 JB 1E 103K-T-A
C8	4030008630	S.CERAMIC	C1608 JF 1C 104Z-T-A
C9	4550004130	S.TANTALUM	F95 1C335MSAAQ2
C10	4030008870	S.CERAMIC	C1608 JB 1H 22K-T-A
C11	4550005430	S.TANTALUM	F95 1E335KWCAQ2

[HM-88/A MAIN BOARD]

REF. NO.	ORDER NO.	DESCRIPTION	
C12	4030008630	S.CERAMIC	C1608 JF 1C 104Z-T-A
C13	4030008880	S.CERAMIC	C1608 JB 1C 223K-T-A
C14	4030008680	S.CERAMIC	C2012 JF 1C 105Z-T-A
C15	4030008630	S.CERAMIC	C1608 JF 1C 104Z-T-A
C16	4030008630	S.CERAMIC	C1608 JF 1C 104Z-T-A
C17	4030008680	S.CERAMIC	C2012 JF 1C 105Z-T-A
C30	4030008900	S.CERAMIC	C1608 JB 1C 333K-T-A
C31	4030008900	S.CERAMIC	C1608 JB 1E 103K-T-A
C37	4030008630	S.CERAMIC	C1608 JF 1C 104Z-T-A
C52	4550004080	S.TANTALUM	F95 0J338MWCAQ2
C53	4550004050	S.TANTALUM	F95 0G478MWCAQ2
C66	4030008690	S.CERAMIC	C1608 SL 1H 330J-T-A
C71	4550004050	S.TANTALUM	F95 0G478MWCAQ2
C72	4550004080	S.TANTALUM	F95 0J108MSAAQ2
C73	4030008880	S.CERAMIC	C1608 JB 1C 153K-T-A
DS1	5040001650	S.LED	SLM-245LMWT-84L
MC1	7700000861	MICROPHONE	WM-62A103
W1	8900003810	CABLE	OPC-374
J2	6510014890	S.CONNECTOR	52207-1690
J3	6510015540	S.CONNECTOR	B4B-ZR-SM3-TF
S1	2260001890	S.SWITCH	SKQDPA
S2	2260001890	S.SWITCH	SKQDPA
S3	2260001890	S.SWITCH	SKQDPA
S4	2260001910	SWITCH	EVQ-QKH 04K
EP1	0910036726	PCB	B 3627F
WS1	8970021350		J lead set

[HM-88/A SW BOARD]

REF. NO.	ORDER NO.	DESCRIPTION	
S1	2260001960	S.SWITCH	EVQ-PJU 05K
S2	2260001960	S.SWITCH	EVQ-PJU 05K
EP1	0910036611	PCB	B 3629A

[HM-88/A LOGIC BOARD]

REF. NO.	ORDER NO.	DESCRIPTION	
IC1	1130002370	S.IC	μPD4028BG-T1
IC2	1140002910	S.IC	μPD7564AG-530
IC3	1110001550	S.IC	S-8054ALB-LM-T1
Q1	1510000770	S.TRANSISTOR	2SA1586-GR (TE85R)
Q2	1510000770	S.TRANSISTOR	2SA1586-GR (TE85R)
D1	1750000110	S.DIODE	1SS272 (TE85R)
D2	1750000110	S.DIODE	1SS272 (TE85R)
D3	1750000110	S.DIODE	1SS272 (TE85R)
D4	1750000110	S.DIODE	1SS272 (TE85R)

S.=Surface mount

[HM-88/A LOGIC BOARD]

REF. NO.	ORDER NO.	DESCRIPTION	
D5	1750000110	S.DIODE	1SS272 (TE85R)
D6	1750000260	S.DIODE	1SS352 (TPH3)
D7	1750000110	S.DIODE	1SS272 (TE85R)
D8	1750000260	S.DIODE	1SS352 (TPH3)
X1	6060000530	S.CERAMIC	CSB600J200T
R1	7030003560	S.RESISTOR	ERJ3GEYJ 103 V (10 kΩ)
R2	7030003390	S.RESISTOR	ERJ3GEYJ 391 V (390 Ω)
R3	7030003330	S.RESISTOR	ERJ3GEYJ 121 V (120 Ω)
R4	7030003560	S.RESISTOR	ERJ3GEYJ 103 V (10 kΩ)
R5	7030003640	S.RESISTOR	ERJ3GEYJ 473 V (47 kΩ)
R6	7030003640	S.RESISTOR	ERJ3GEYJ 473 V (47 kΩ)
R7	7030003640	S.RESISTOR	ERJ3GEYJ 473 V (47 kΩ)
R8	7030003640	S.RESISTOR	ERJ3GEYJ 473 V (47 kΩ)
R9	7030003640	S.RESISTOR	ERJ3GEYJ 473 V (47 kΩ)
R10	7030003640	S.RESISTOR	ERJ3GEYJ 473 V (47 kΩ)
R11	7030003640	S.RESISTOR	ERJ3GEYJ 473 V (47 kΩ)
R12	7030003640	S.RESISTOR	ERJ3GEYJ 473 V (47 kΩ)
R13	7030003800	S.RESISTOR	ERJ3GEYJ 105 V (1 MΩ)
R14	7030003640	S.RESISTOR	ERJ3GEYJ 473 V (47 kΩ)
R15	7030003530	S.RESISTOR	ERJ3GEYJ 562 V (5.6 kΩ)
R17	7030003320	S.RESISTOR	ERJ3GEYJ 101 V (100 Ω)
C1	4030006900	S.CERAMIC	C1608 JB 1E 103K-T-A
C2	4030006750	S.CERAMIC	C1608 SL 1H 101J-T-A
C3	4030006750	S.CERAMIC	C1608 SL 1H 101J-T-A
C4	4030006900	S.CERAMIC	C1608 JB 1E 103K-T-A
C5	4030008920	S.CERAMIC	C1608 JB 1C 473K-T-A
DS1	5040001650	S.LED	SLM-245LMWT-84L
W1	8900004010	CABLE	OPC-382
S1	2260001710	S.SWITCH	CHS-04TA
S2	2260001680	S.SWITCH	SKQDPB
EP1	0910036743	PCB	B 3628C

[HM-88/A COVER]

REF. NO.	ORDER NO.	DESCRIPTION	
MP1	8210009261		1135 front panel(B)- 1 (HM-88A)
MP1	8210009251		1135 front panel (A) - 1 (HM-88)
MP2	8010012870	PANEL	1135 rear panel
MP3	8010012880	KEY	1135 10key
MP4	8930025170	BUTTON	1135 PTT button
MP5	8930025180	BUTTON	1135 4 - button
MP7	8930025200	BUTTON	1135 3 - button
MP8	8010012890	PLATE	1135 hook plate
MP9	8010012901	HOLDER	1135 switch holder- 1
MP10	8010014921	HOLDER	1135 battery holder (A)- 1
MP11	8310026810	PLATE	1135 key plate
MP13	8930025220	TERMINAL	1135 terminal (A)
MP14	8930025230	TERMINAL	1135 terminal (B)
MP16	8930025820	RUBBER	1135 switch
MP18	8930014940	HOLDER	752 microphone holder
MP19	8810006100	SCREW	PH B0 No. 0 M2 × 3.5 NI
MP20	8810007380	SCREW	FFH No. 0 M2 × 4.5 ZK
MP21	8810006100	SCREW	PH B0 No. 0 M2 × 3.5 NI
MP22	8810007380	SCREW	FFH PT No. 0 M2 × 4.5 ZK
MP23	8810007290	SCREW	FH B0 M2.6 × 20 NI
MP24	8810007280	SCREW	OH B0 M2.6 × 20 ZK

Screw abbreviation FH: Flat head FFH:Flat fillister head  
 PH: Pan head OH: Oval countersunk head  
 S.=Surface mount

[HM-88/A ACC]

REF. NO.	ORDER NO.	DESCRIPTION	
W1	8900003720	CABLE	OPC-336



# BOARD LAYOUT

## DISPLAY UNIT

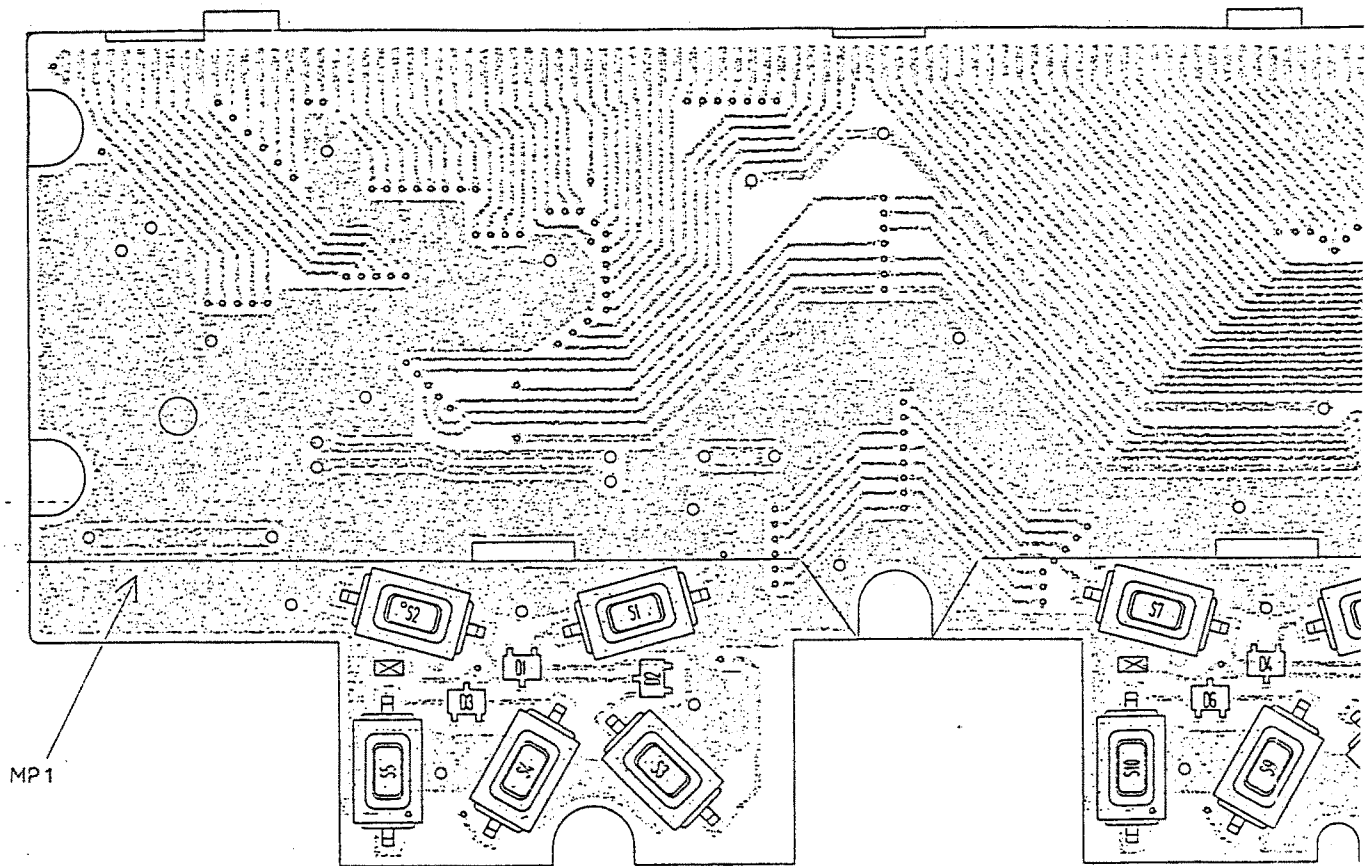

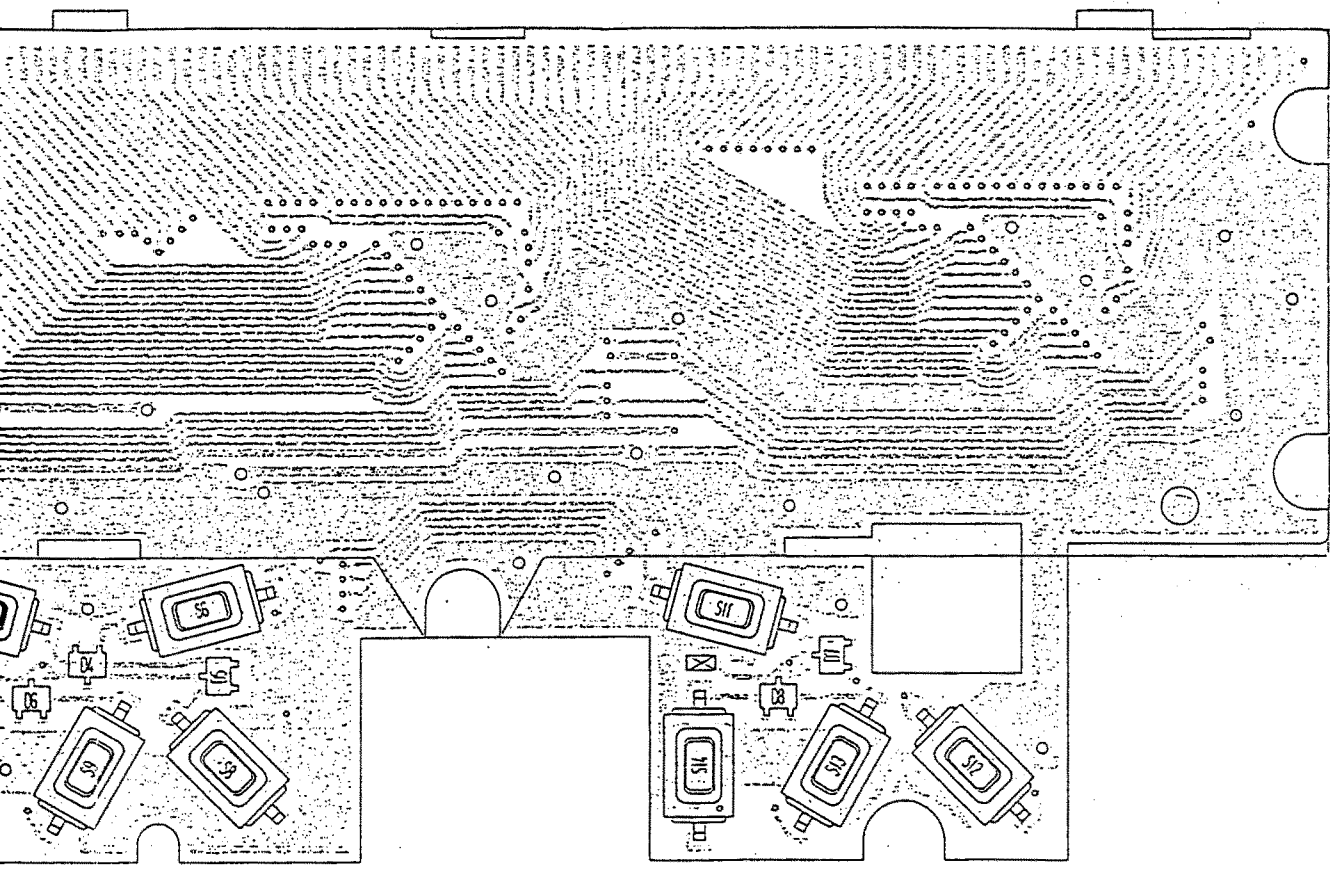

# DISPLAY UNIT

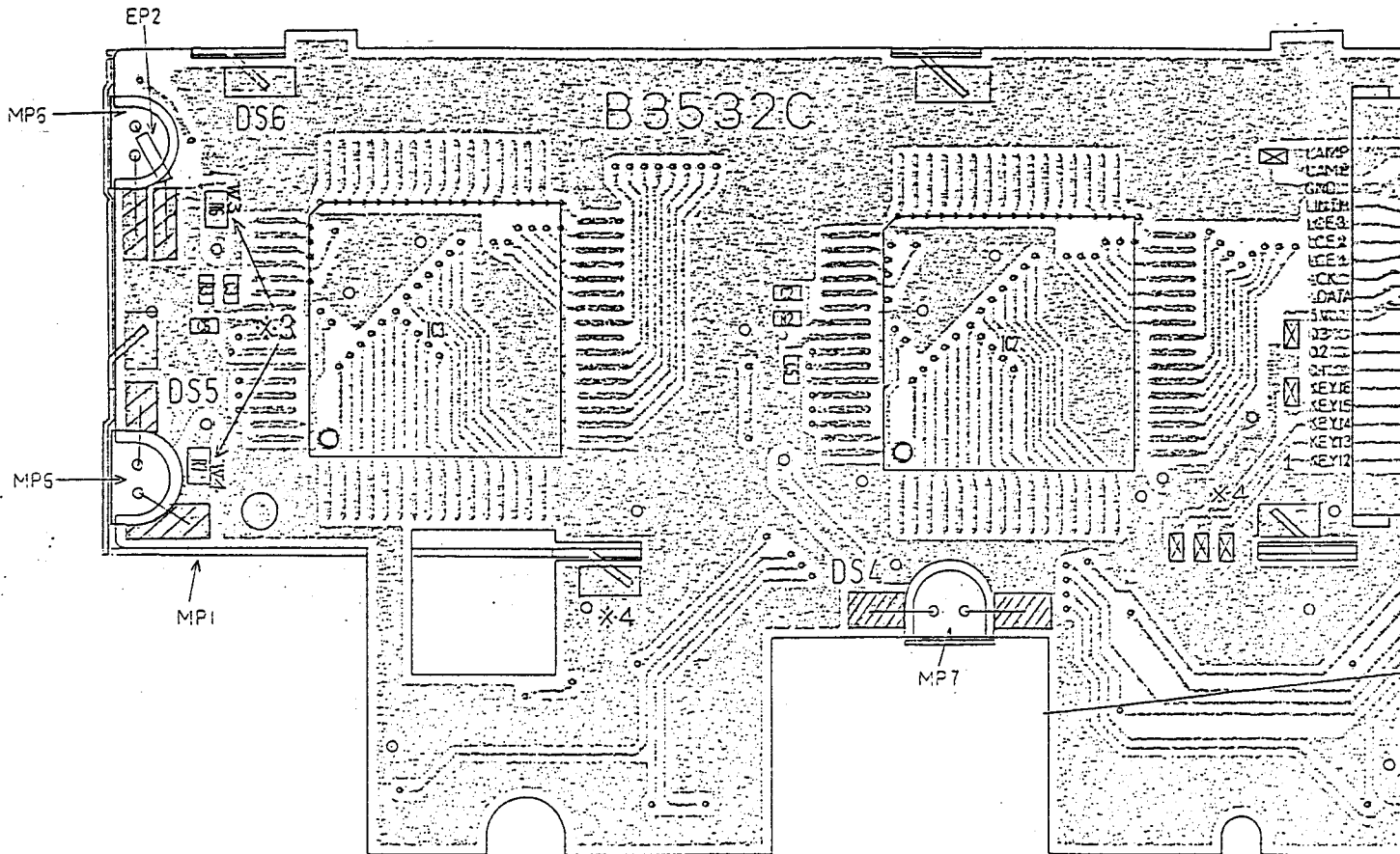

- LAMP
- LAMP
- GND
- LINH
- LCE3
- LCE2
- LCE1
- LCK
- LDATA
- 5V
- Q3
- Q2
- Q1
- KEY16
- KEY15
- KEY14
- KEY13
- KEY12

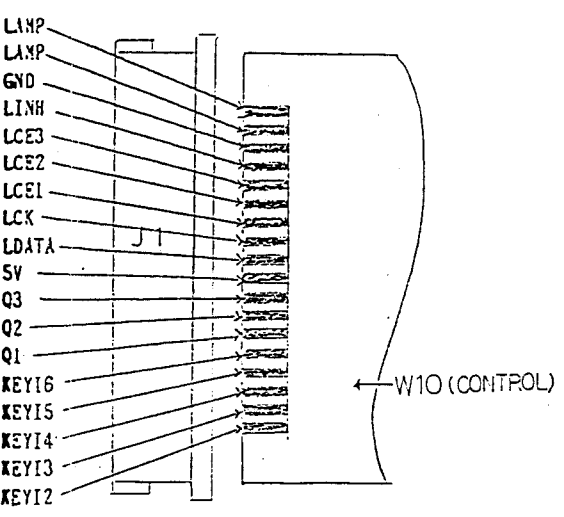
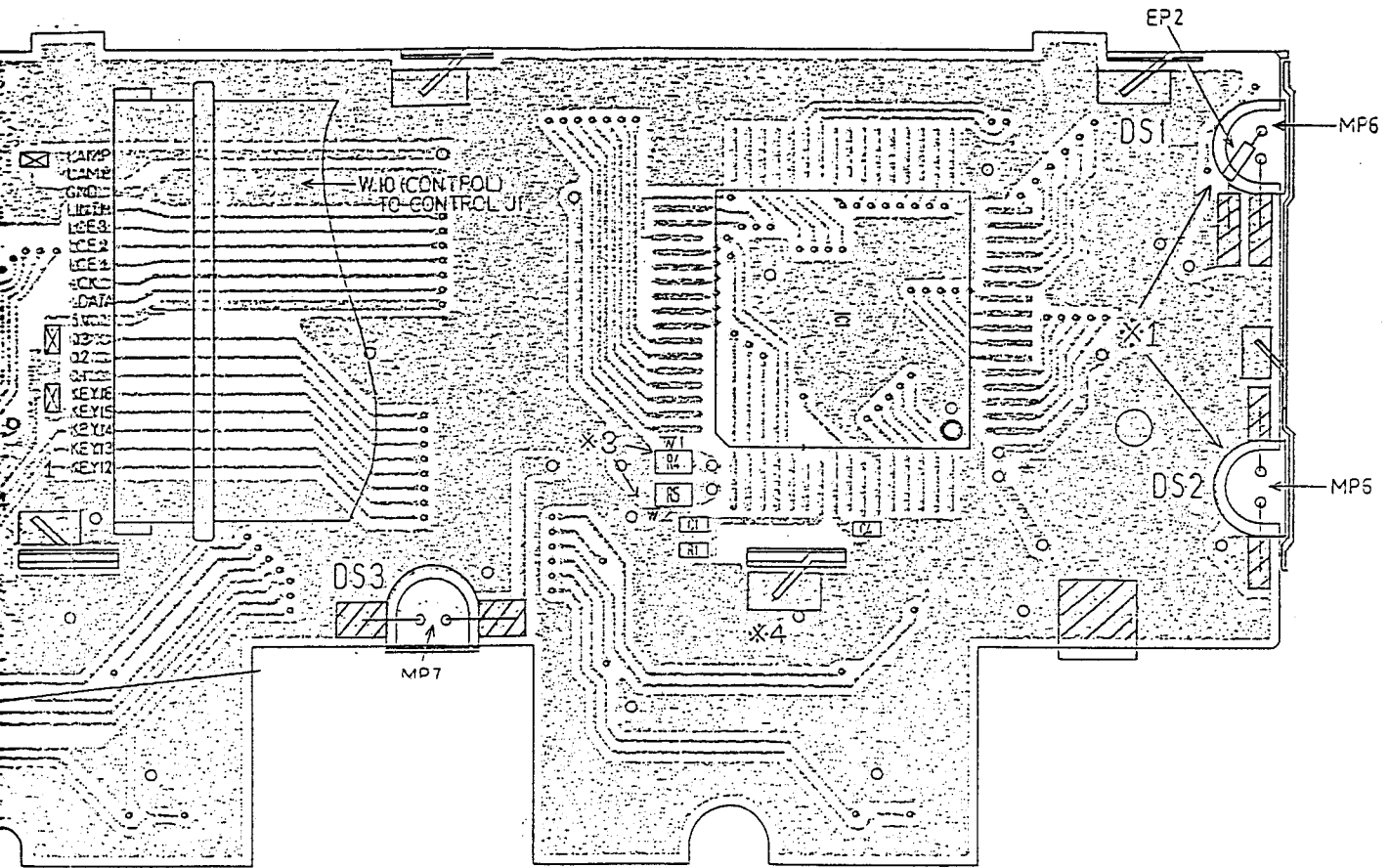

# HM-88/A LOGIC BOARD

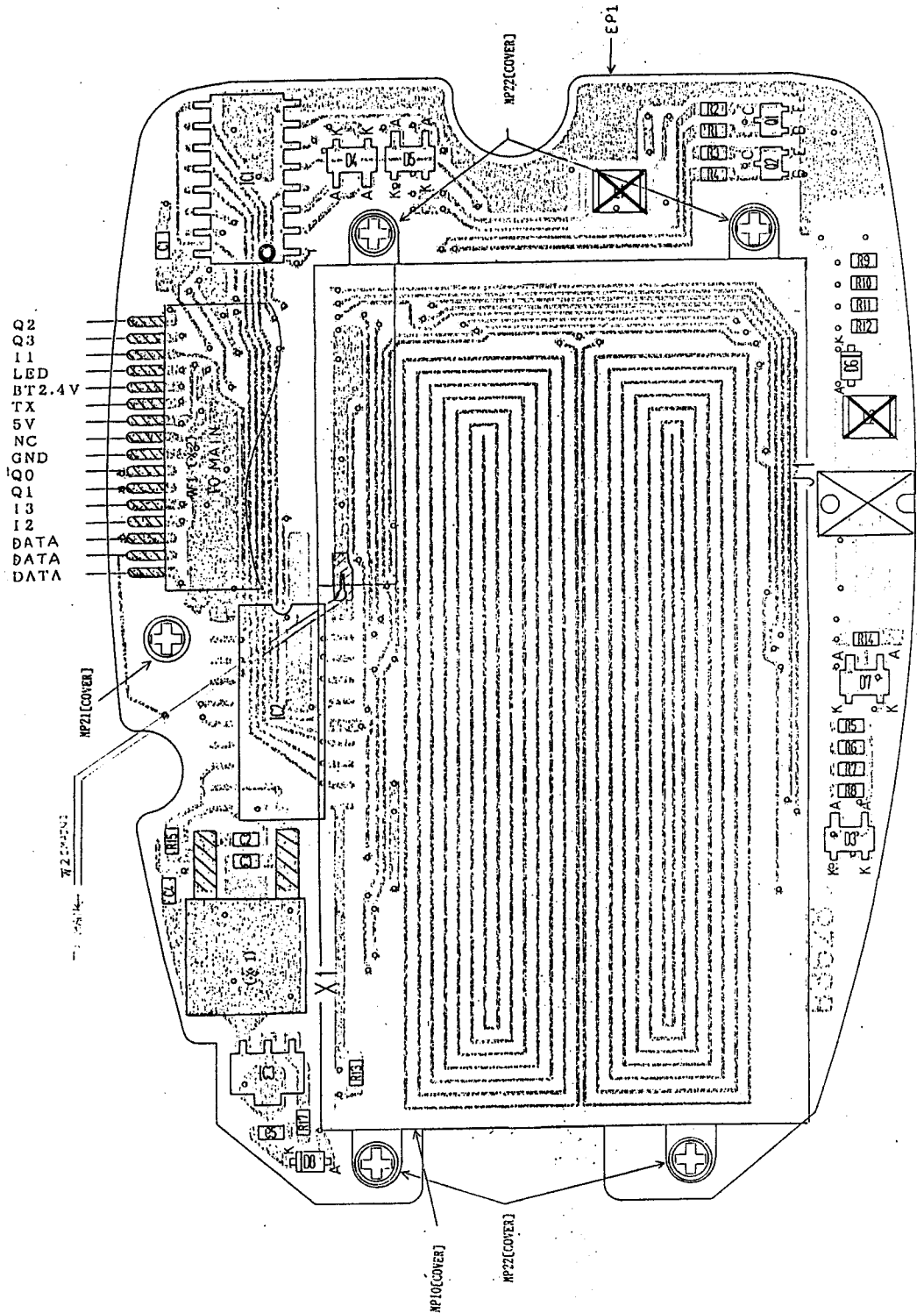

# HM-88/A SW BOARD

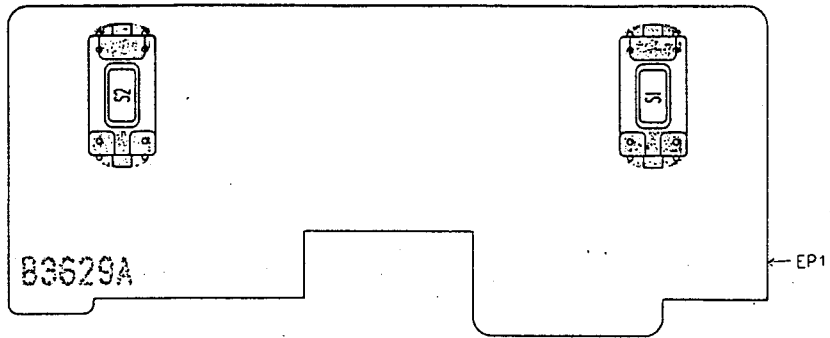

# HM-88/A MAIN BOARD

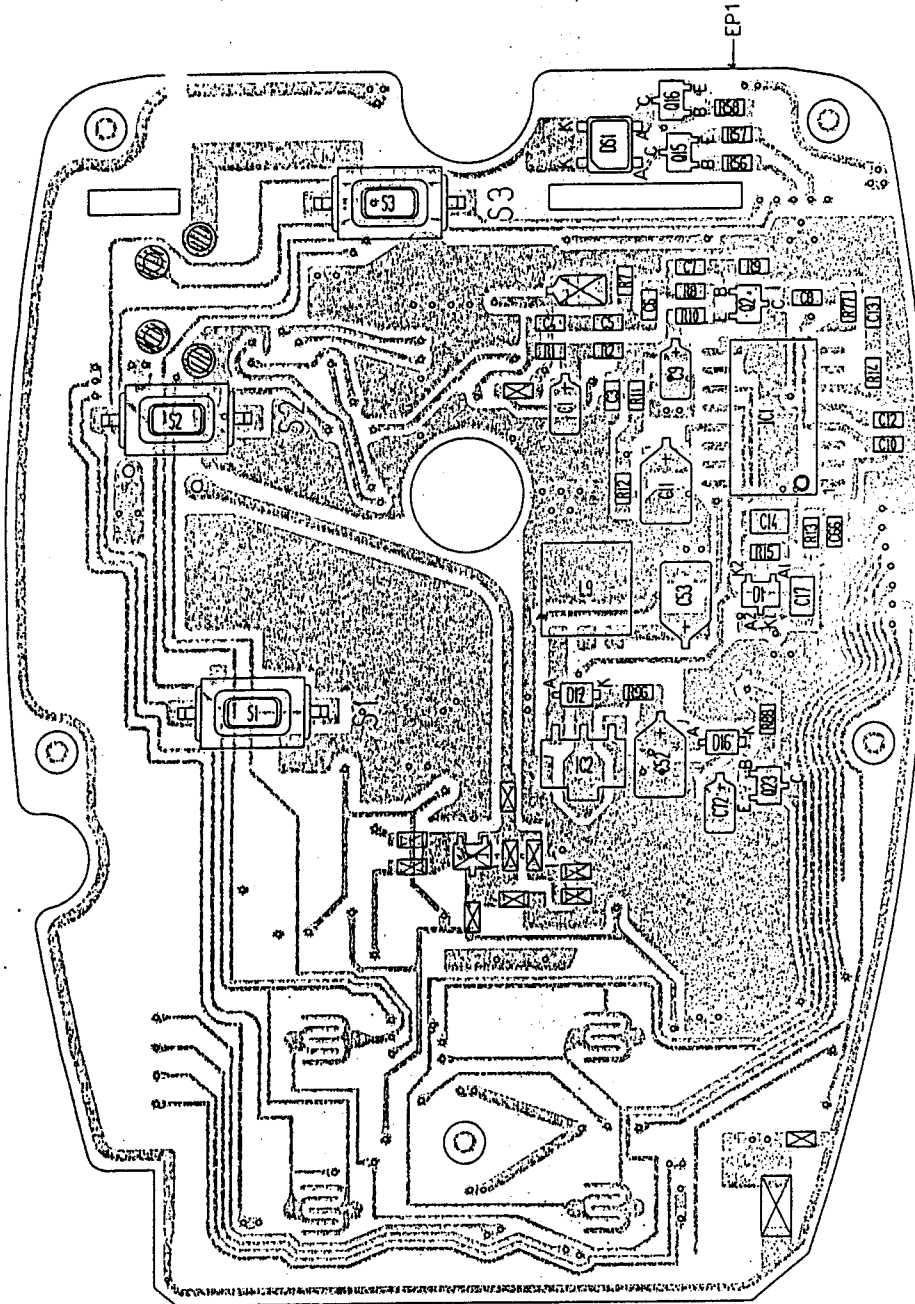

**HM-88/A**  
**LOGIC BOARD**

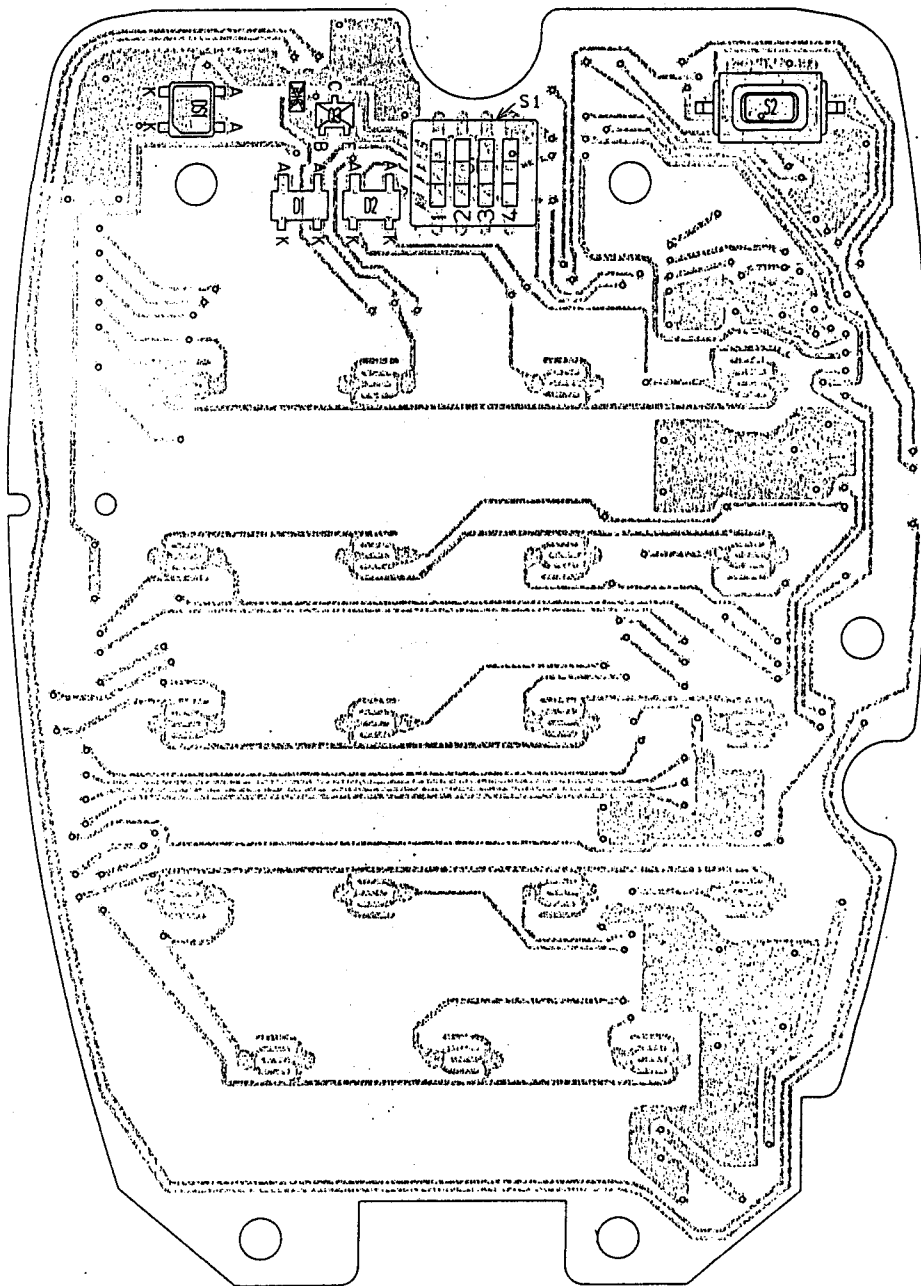

# HM-88/A SW BOARD

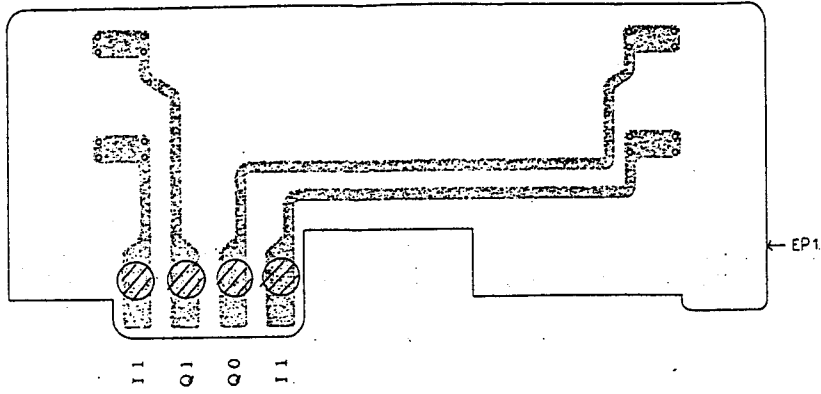

# HM-88/A MAIN BOARD

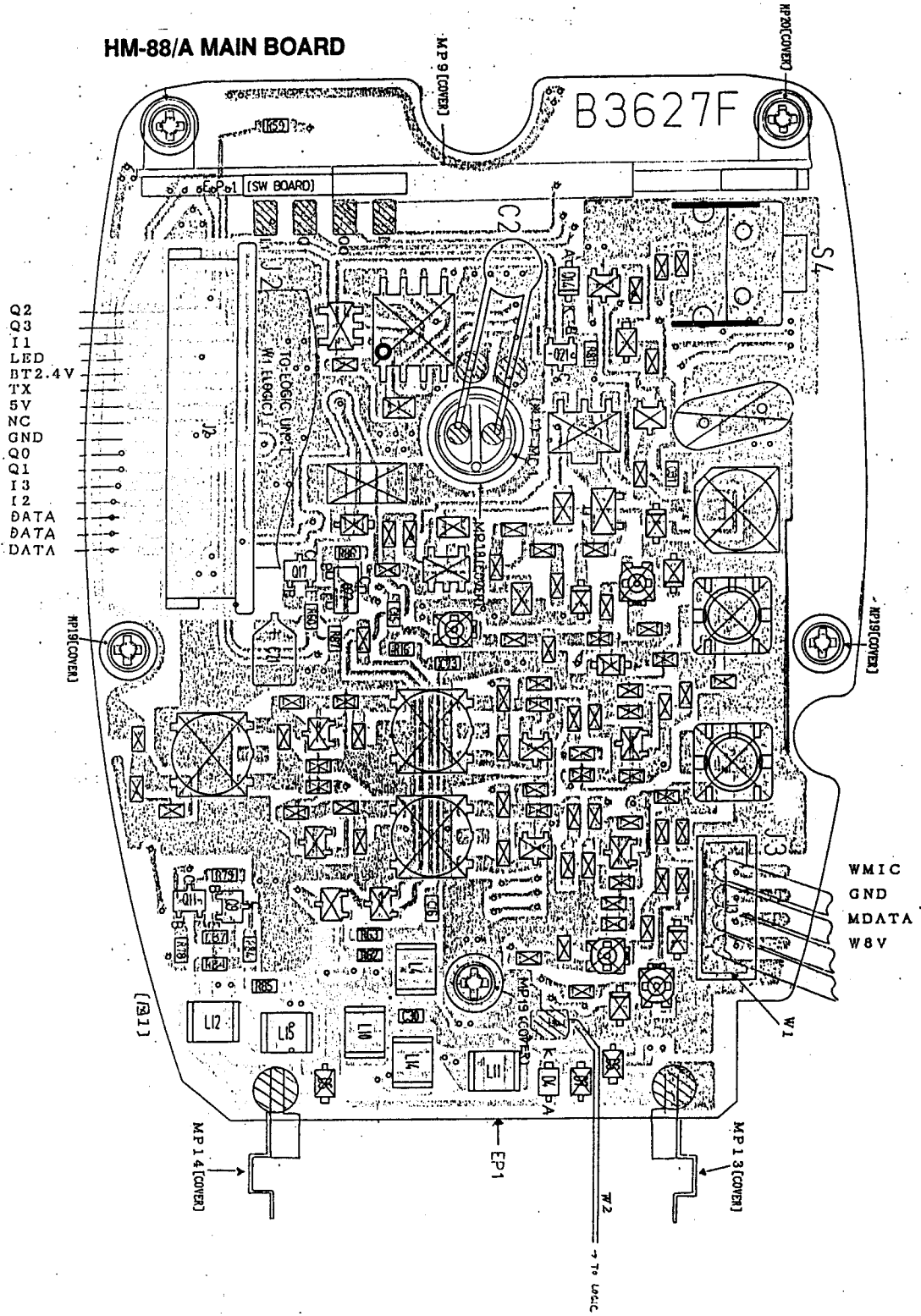



LOGIC UNIT

AF J2

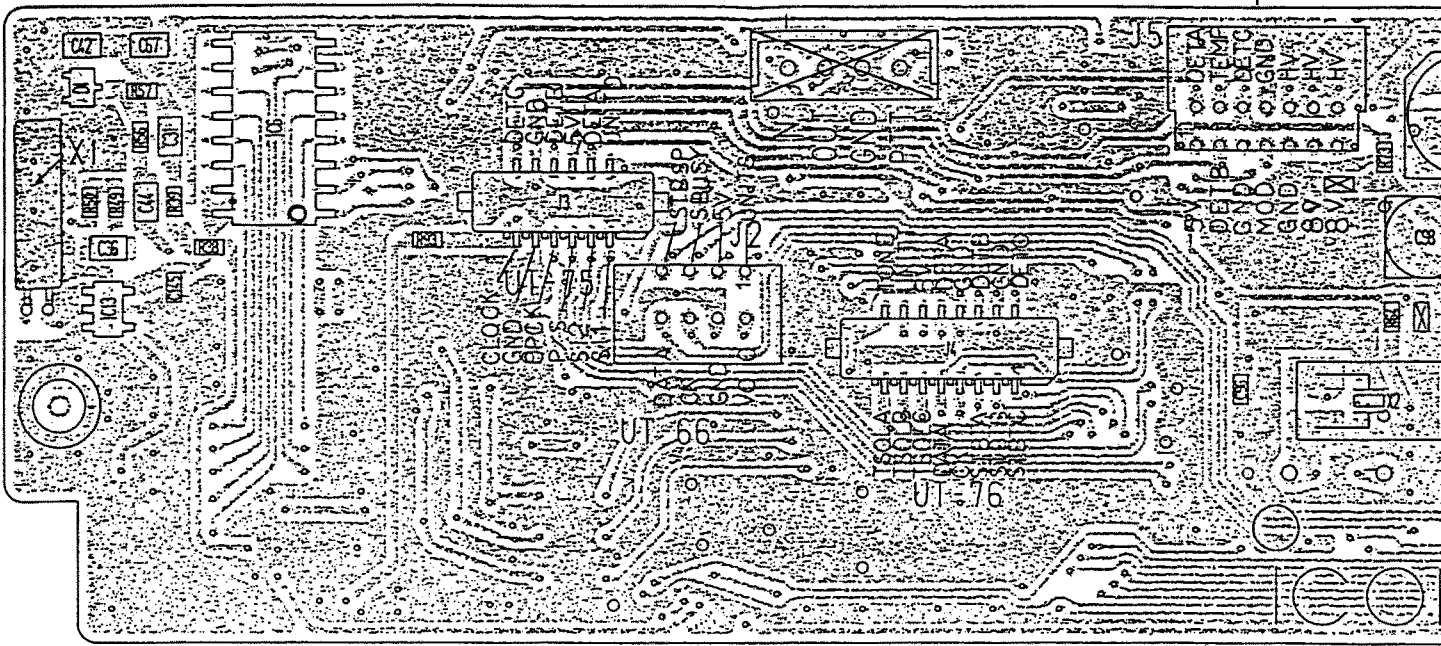

EP1

AF UNIT

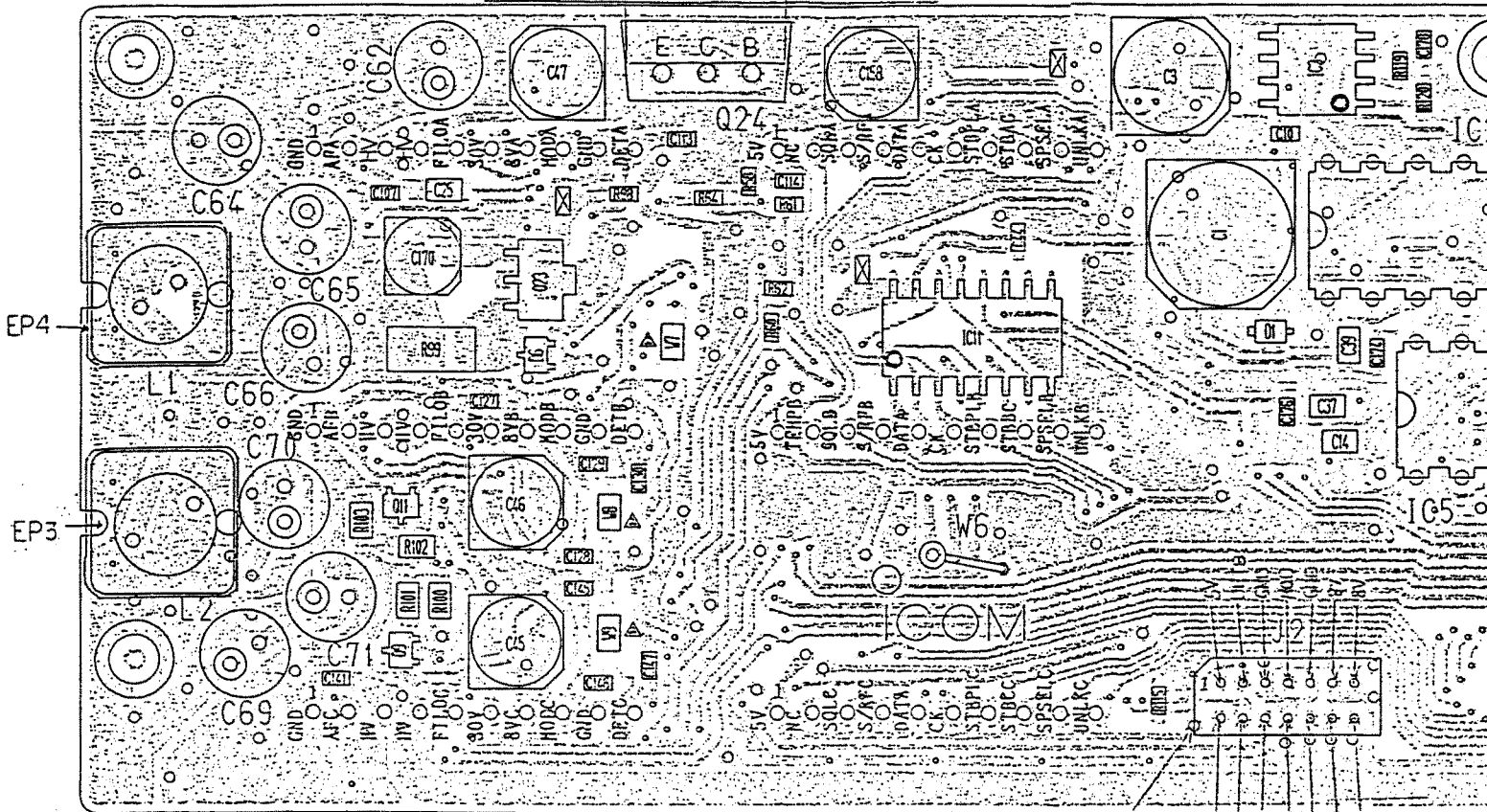

TO LOGIC J5

DETA  
TEMP  
DETC  
GND  
HV  
HV  
HV

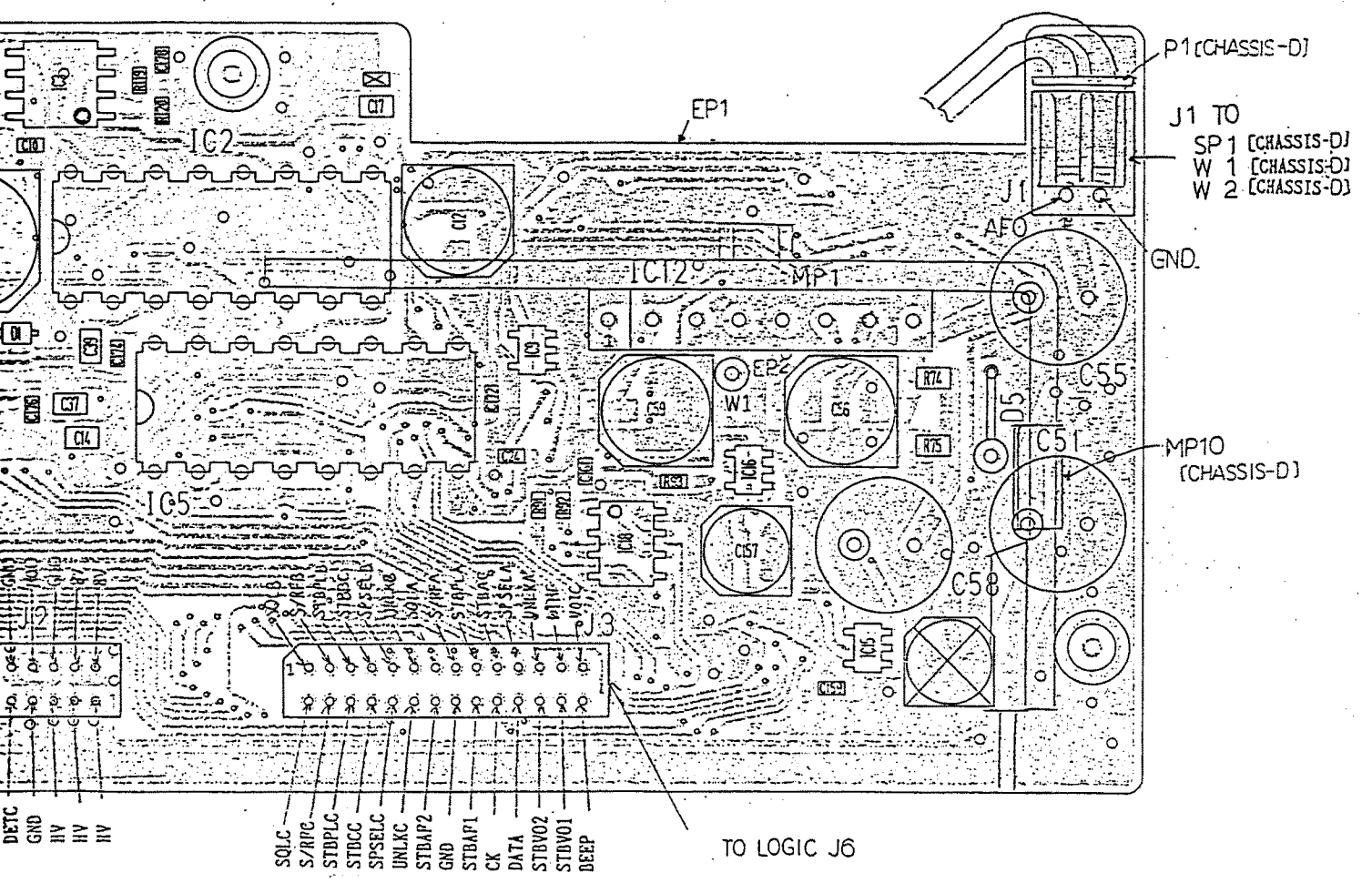
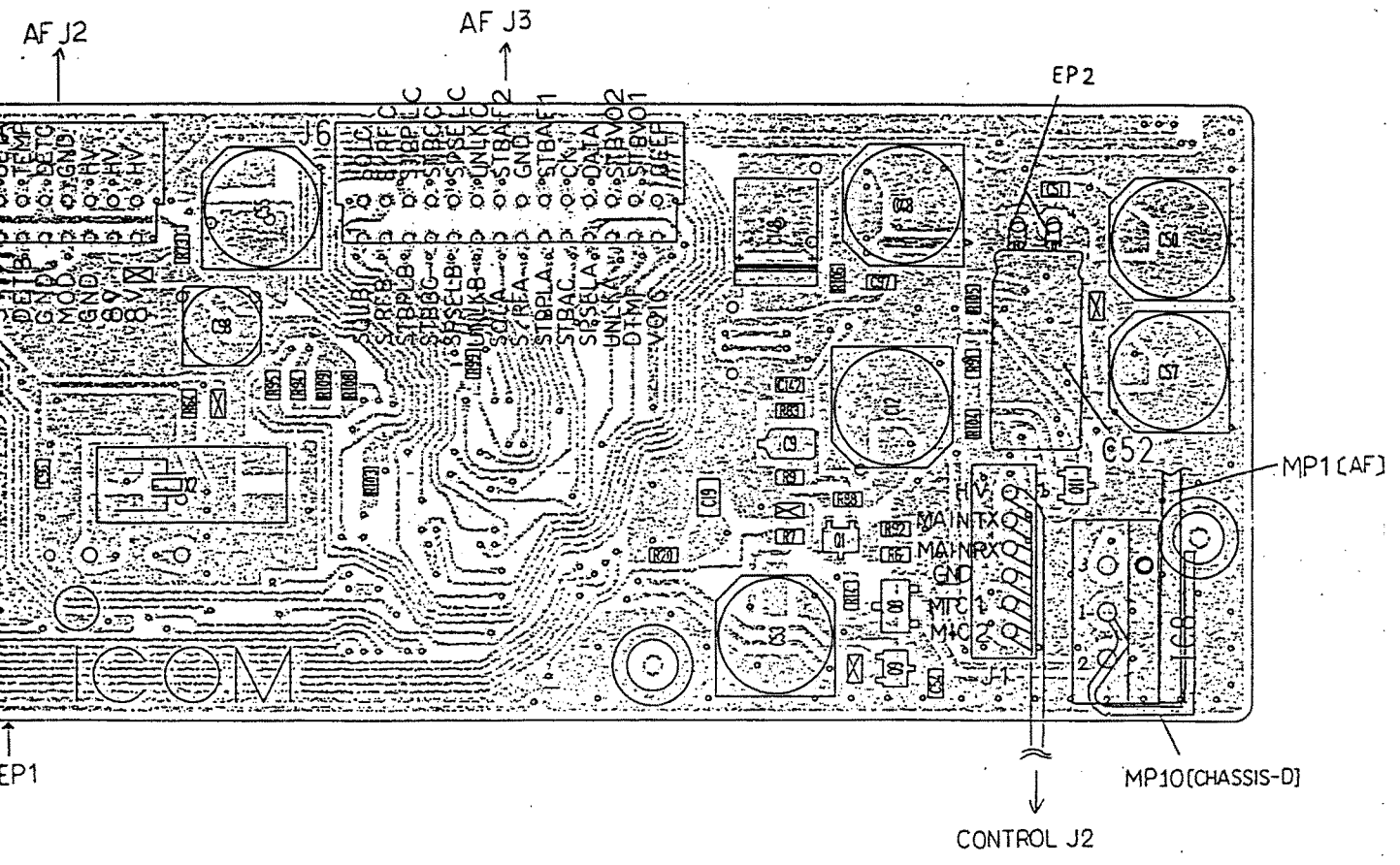

**LOGIC UNIT**

MP8  
(CHASSIS-D)

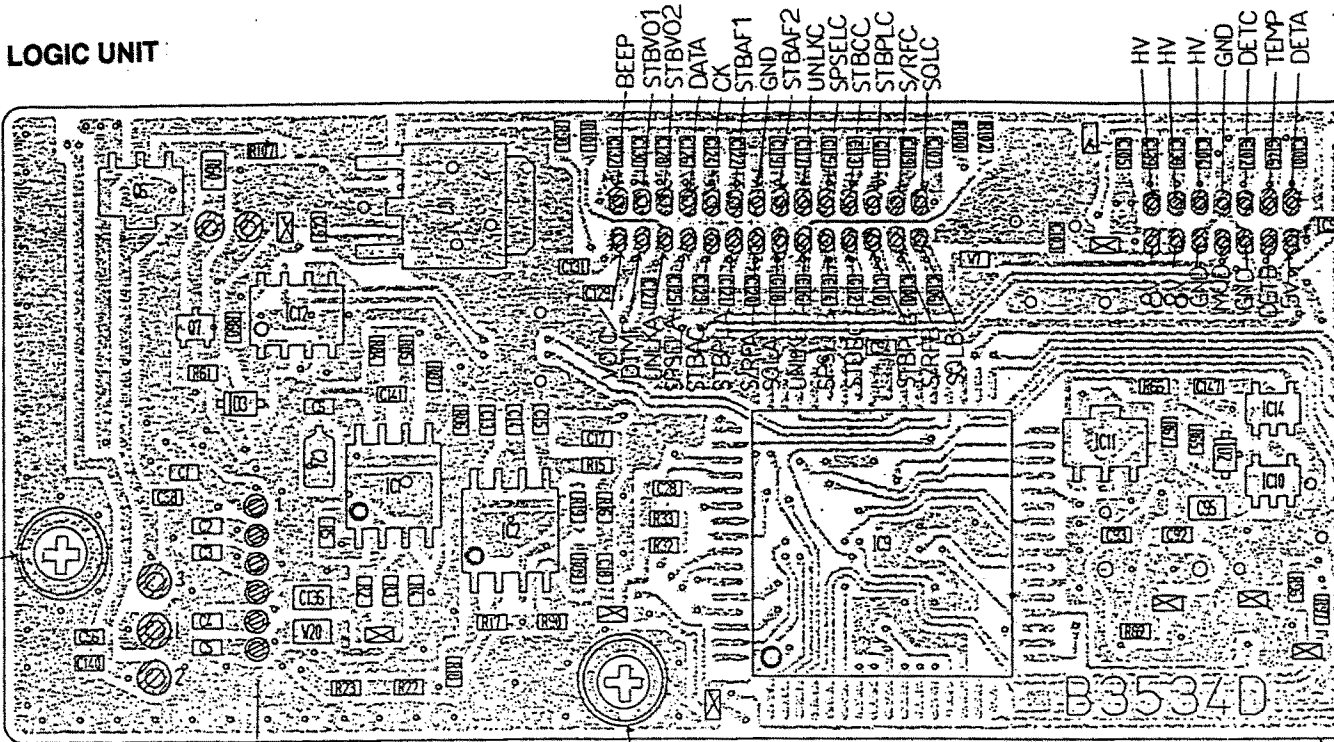

MP8 (CHASSIS-D)

- ⊙ HV
- ⊙ MAINTX
- ⊙ MAINRX
- ⊙ GND
- ⊙ MIC 1
- ⊙ MIC 2

BEEP  
STBVO1  
STBVO2  
DATA  
CK  
STBAF1  
GND  
STBAF2  
UNLNC  
SPSELC  
STBCC  
STBPLC  
S/RFC  
SOLC  
HV  
HV  
HV  
GND  
DETC  
TEMP  
DETA

**AF UNIT**

MP9  
(CHASSIS-D)

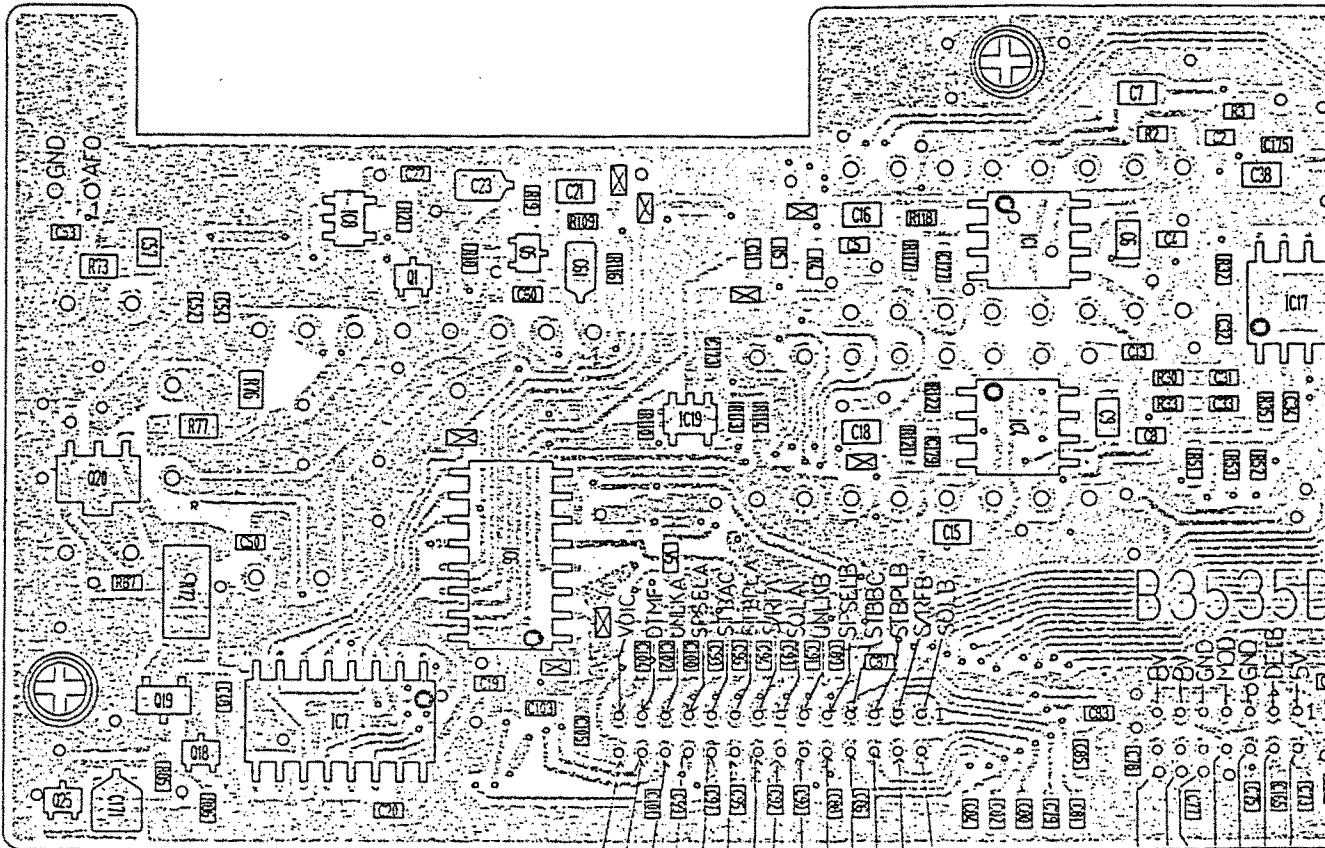

MP9 (CHASSIS-D)

BEEP  
STBVO1  
STBVO2  
DATA  
CK  
STBAF1  
GND  
STBAF2  
UNLNC  
SPSELC  
STBCC  
STBPLC  
S/RFC  
SOLC

HV  
HV  
HV  
GND  
DETC  
TEMP  
DETA

GND  
DETC  
TEMP  
DETA

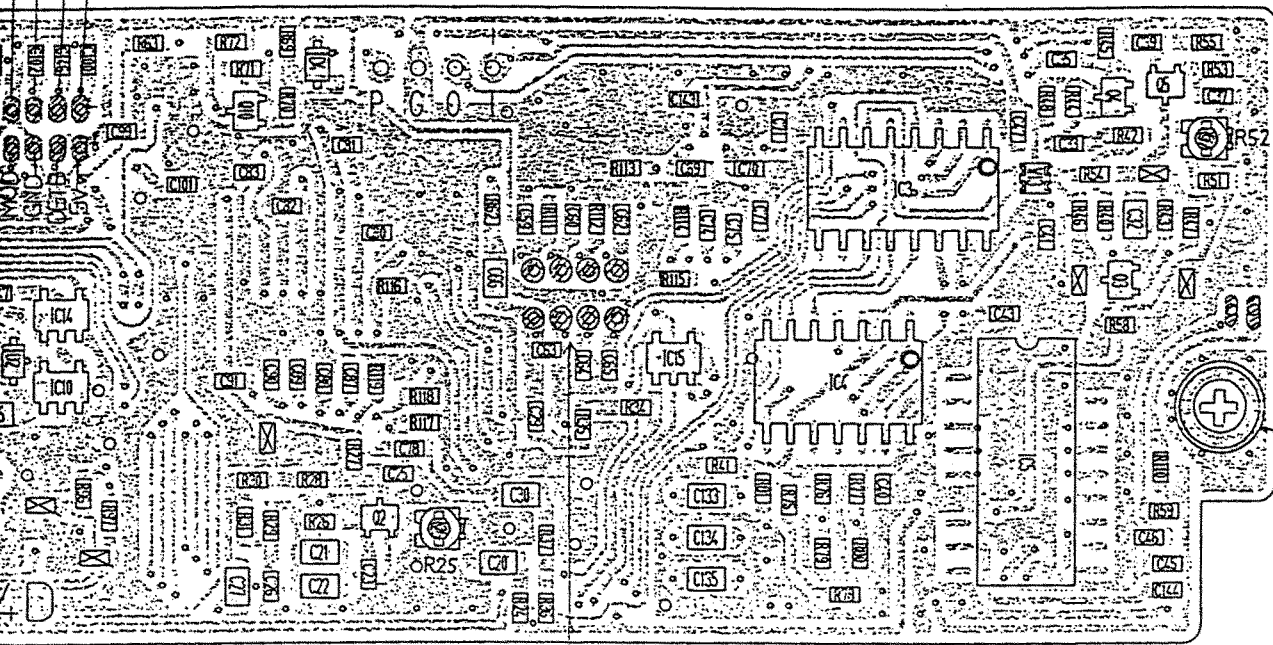

EP1

VOIC- UNITS  
GND- 5V  
CK- SBUSY  
DATA- STBSP

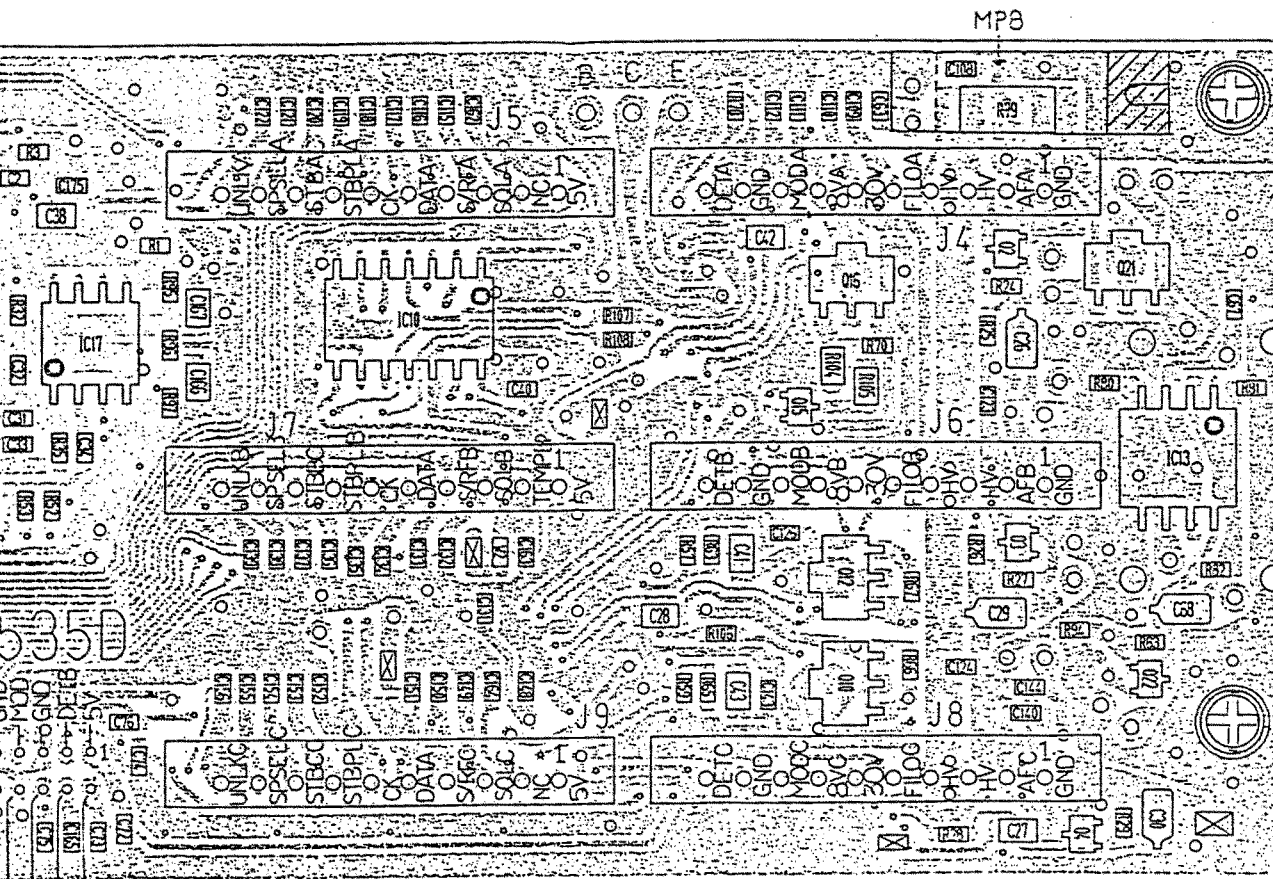

MP8

MP9  
[CHASSIS-D]

MP9  
[CHASSIS-D]

GND  
DETC  
TEMP  
DETA

**TONE UNIT  
(U.S.A. only)**

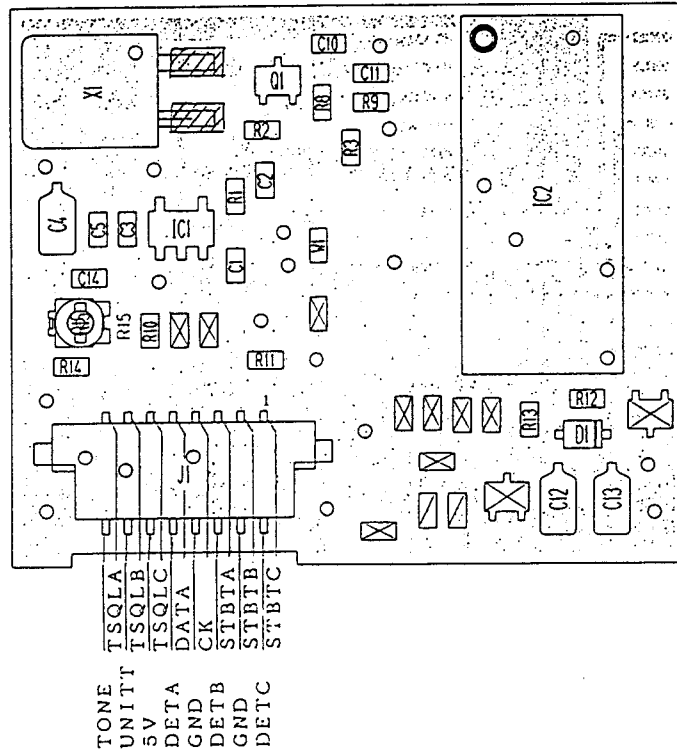

**TONE UNIT  
(U.S.A. only)**

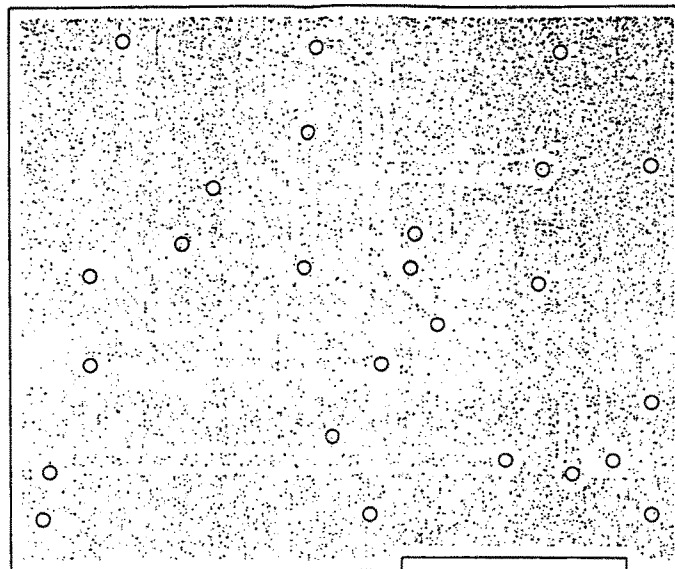

# MAIN-A UNIT

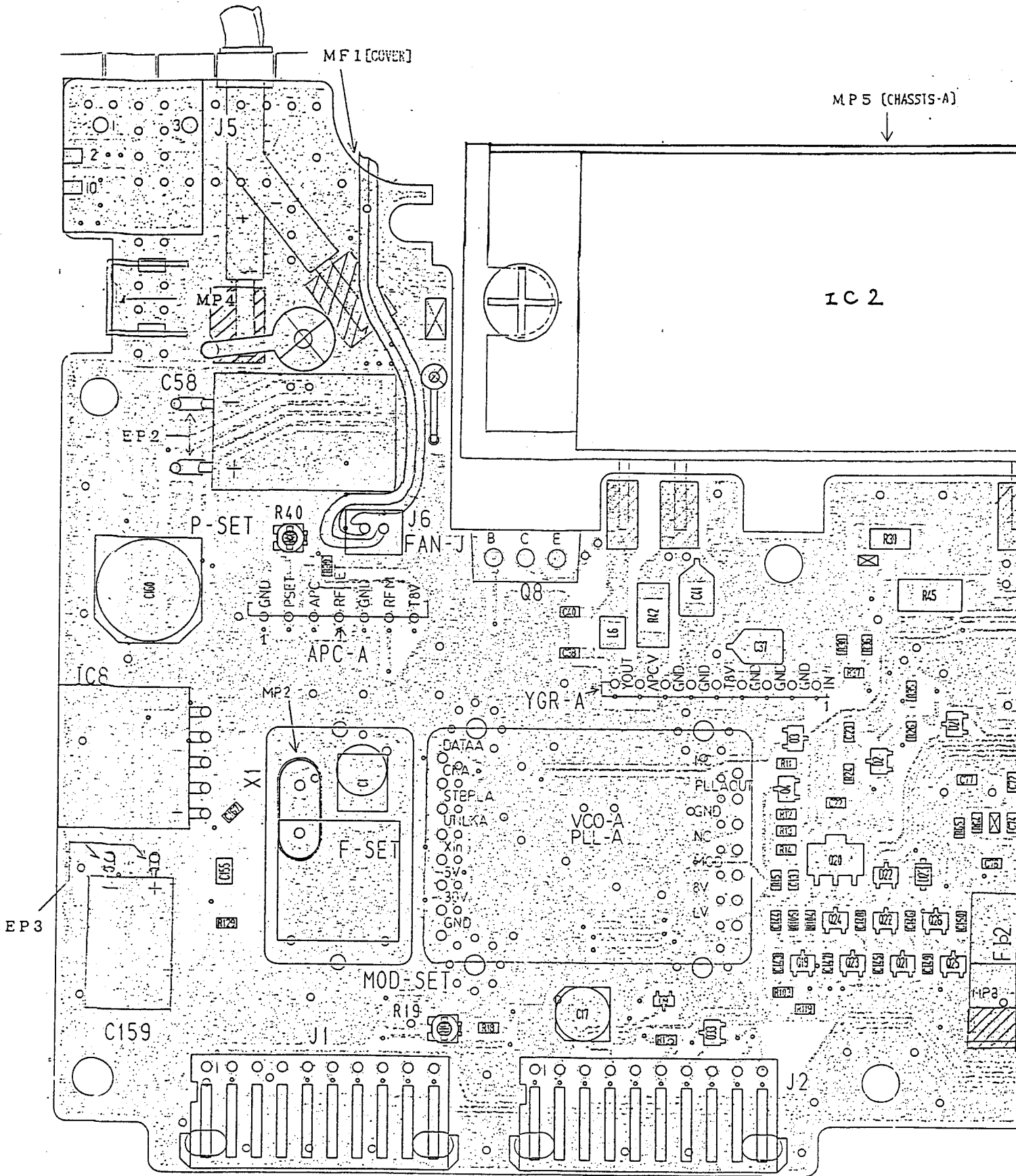

GND  
AFA  
IIV  
IIV  
FILOA  
30V  
8VA  
MODA  
GND  
DETA

5V  
NC  
SQLA  
S/RFA  
DATA  
CK  
STBPLA  
STBAC  
SPSELA  
UNLKA

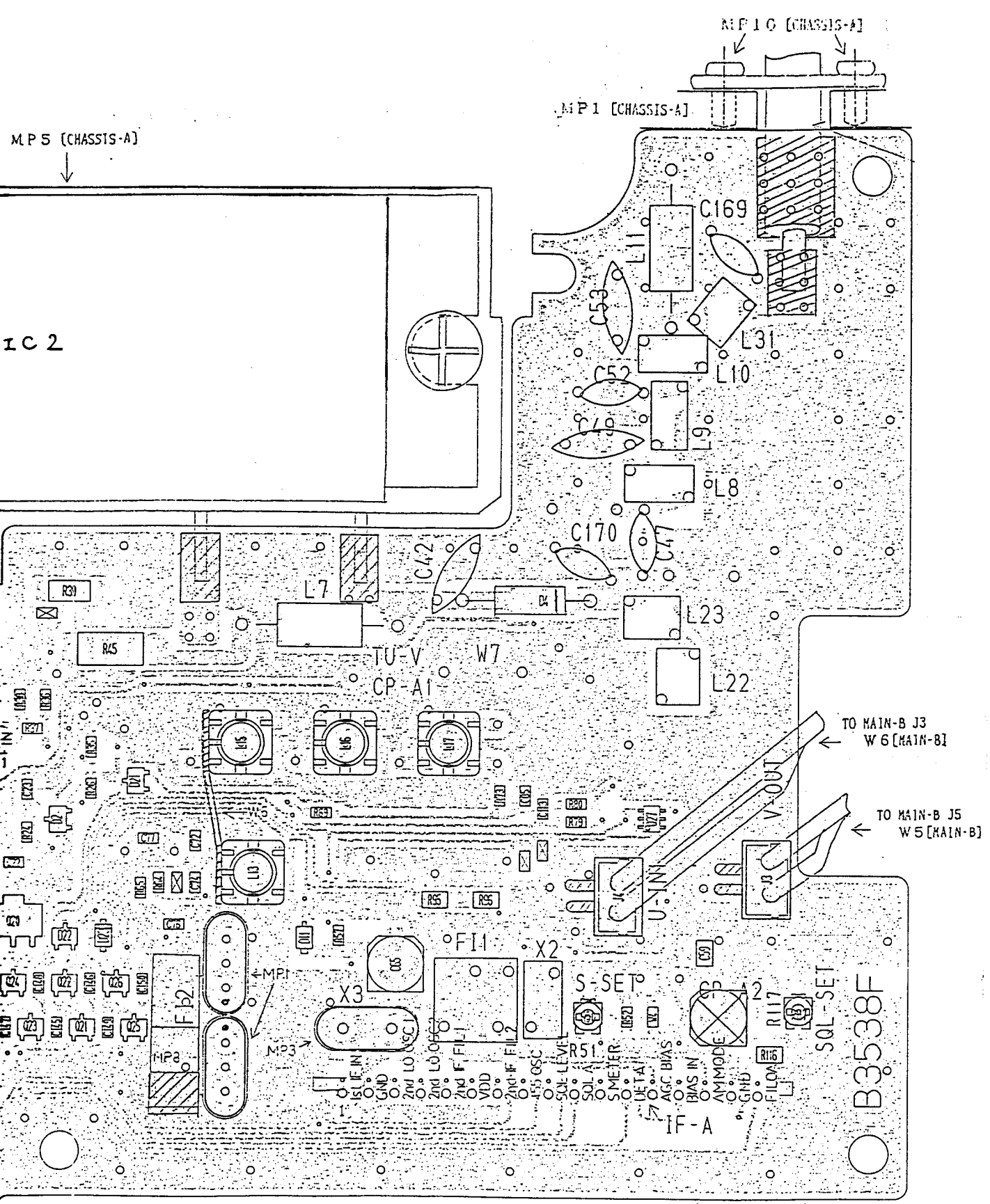

# MAIN-A UNIT

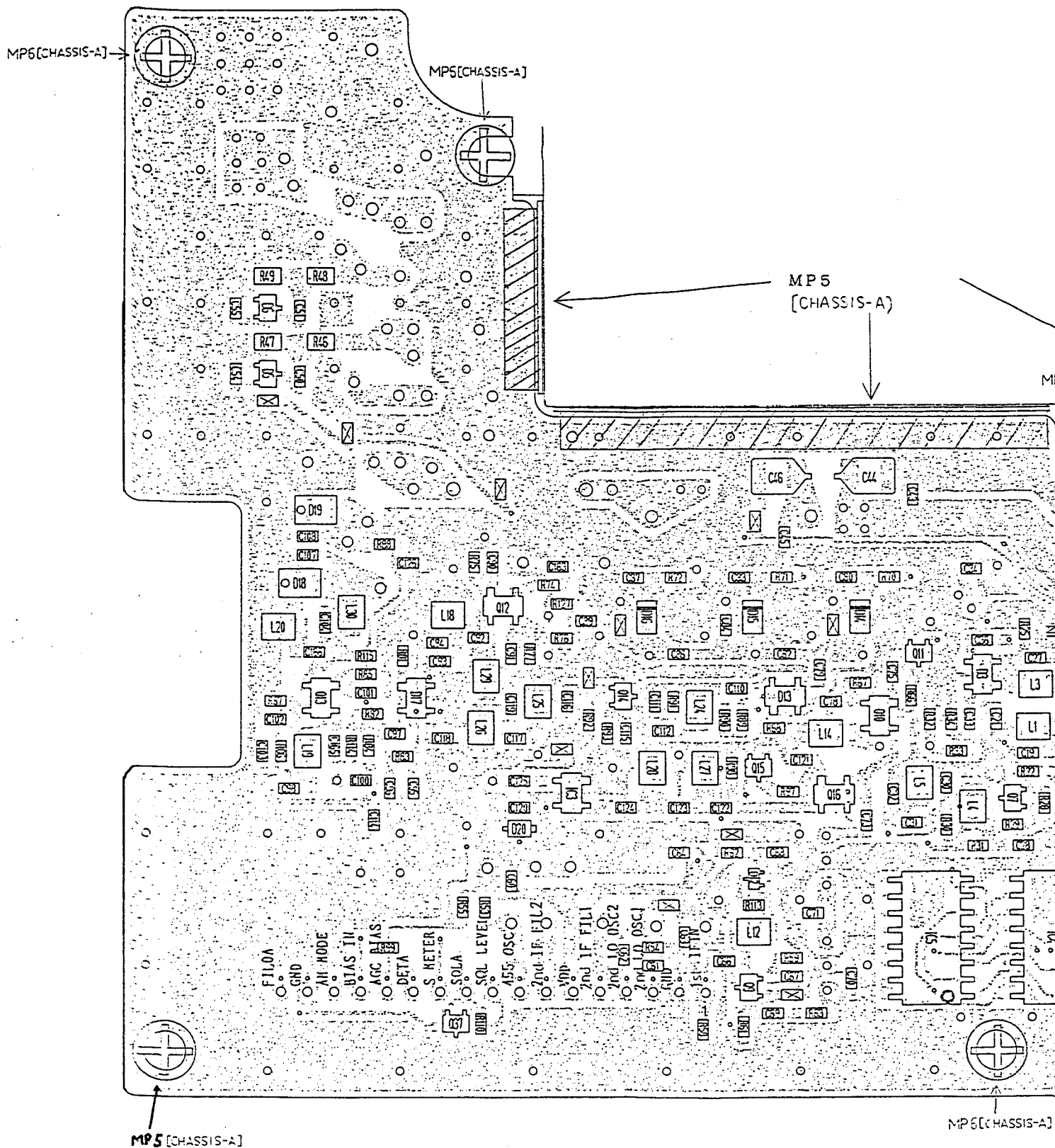

MP6 [CHASSIS-A]

MP5 [CHASSIS-A]

MP5 [CHASSIS-A]

MP5 [CHASSIS-A]

MP6 [CHASSIS-A]



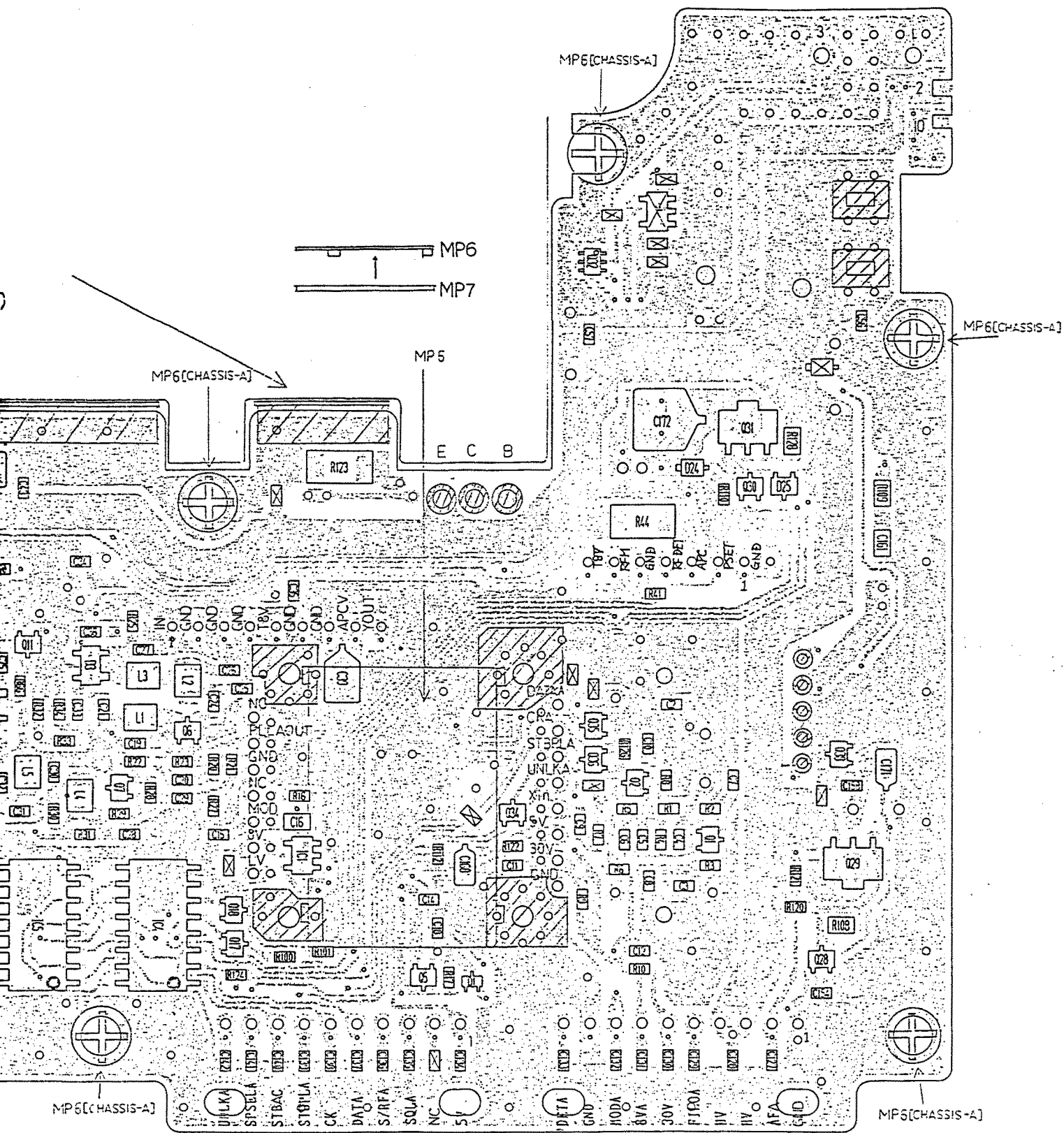

### PLL-A BOARD

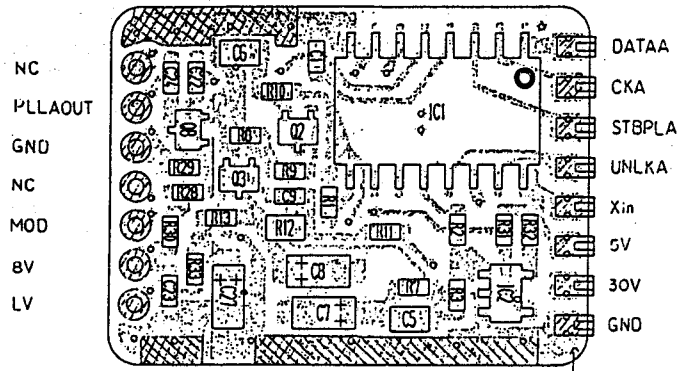

### VCO-A BOARD

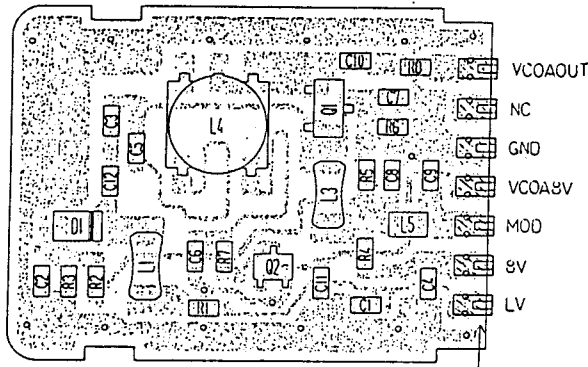

### YGR-A BOARD

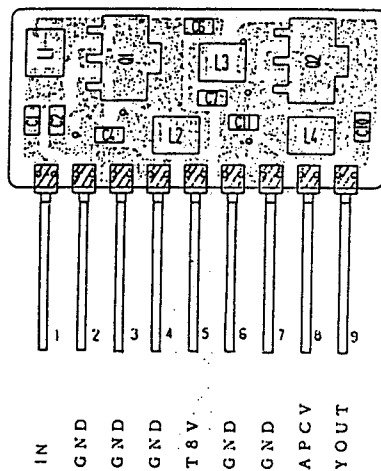

### APC-A BOARD

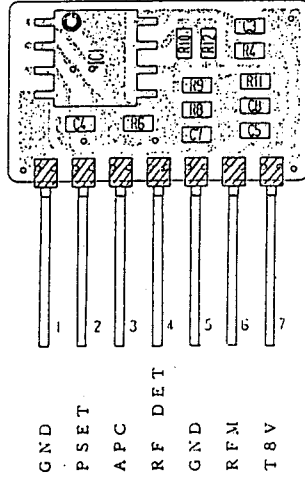

### IF-A BOARD

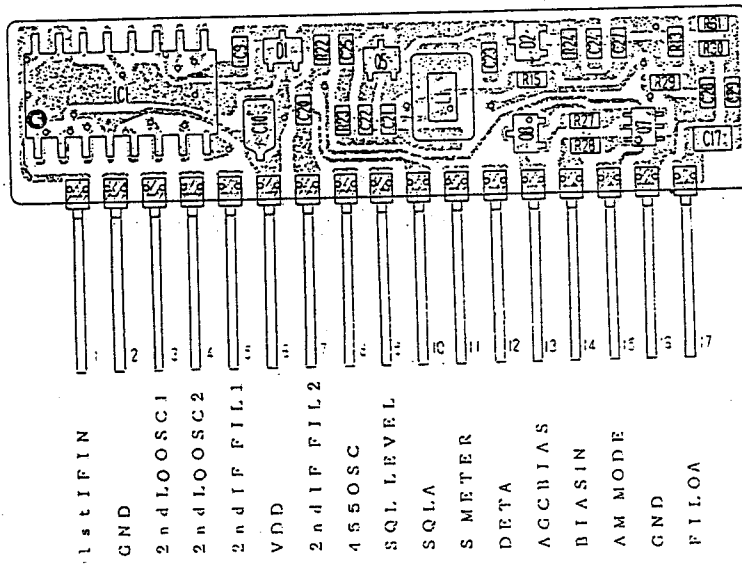

### APC-A BOARD

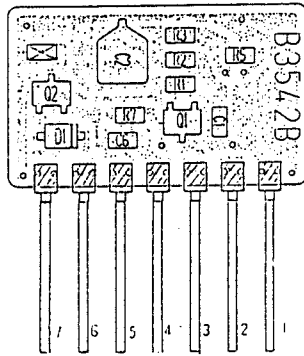

1 T & V  
 2 R F M  
 3 G N D  
 4 R F D E T  
 5 A P C  
 6 P S E T  
 7 G N D

### IF-A BOARD

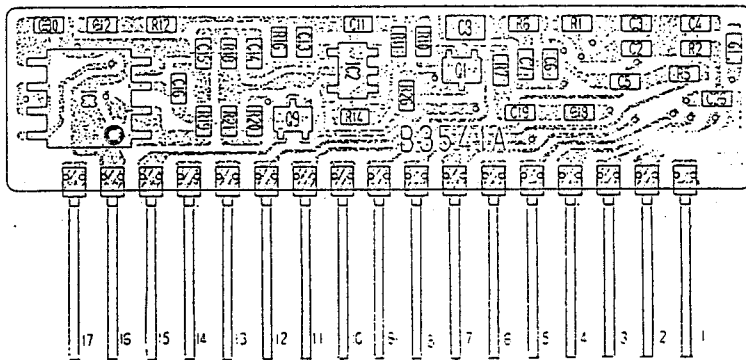

1 I S T I F I N  
 2 G N D  
 3 2 n d L O O S C 1  
 4 2 n d L O O S C 2  
 5 2 n d I F F I L 1  
 6 V D D  
 7 2 n d I F F I L 2  
 8 4 5 5 0 S C  
 9 S Q L L E V E L  
 10 S Q L A  
 11 S M E T E R  
 12 D E T A  
 13 A G C R I A S  
 14 B I A S I N  
 15 A M M O D E  
 16 G N D  
 17 P I L O A

### PLL-A BOARD

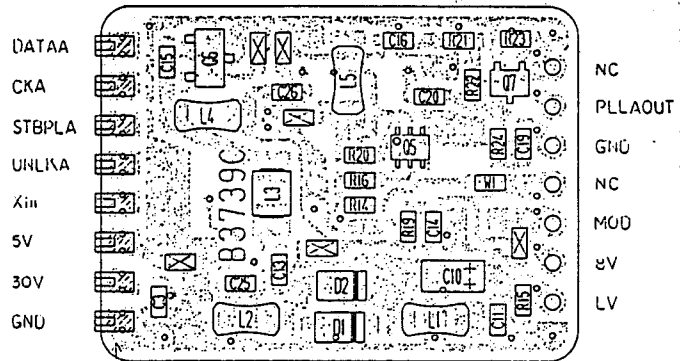

### VCO-A BOARD

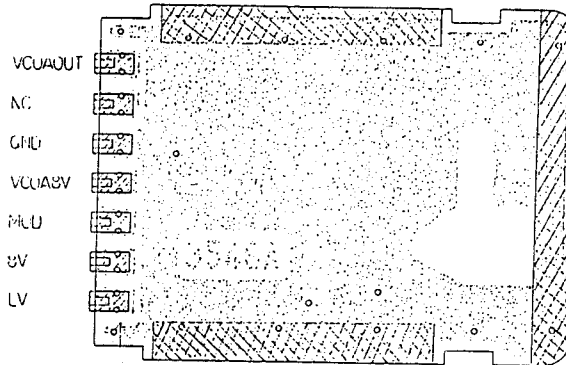

### YGR-A BOARD

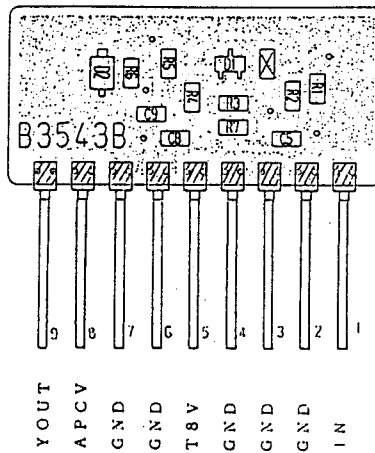

**MAIN-B UNIT**

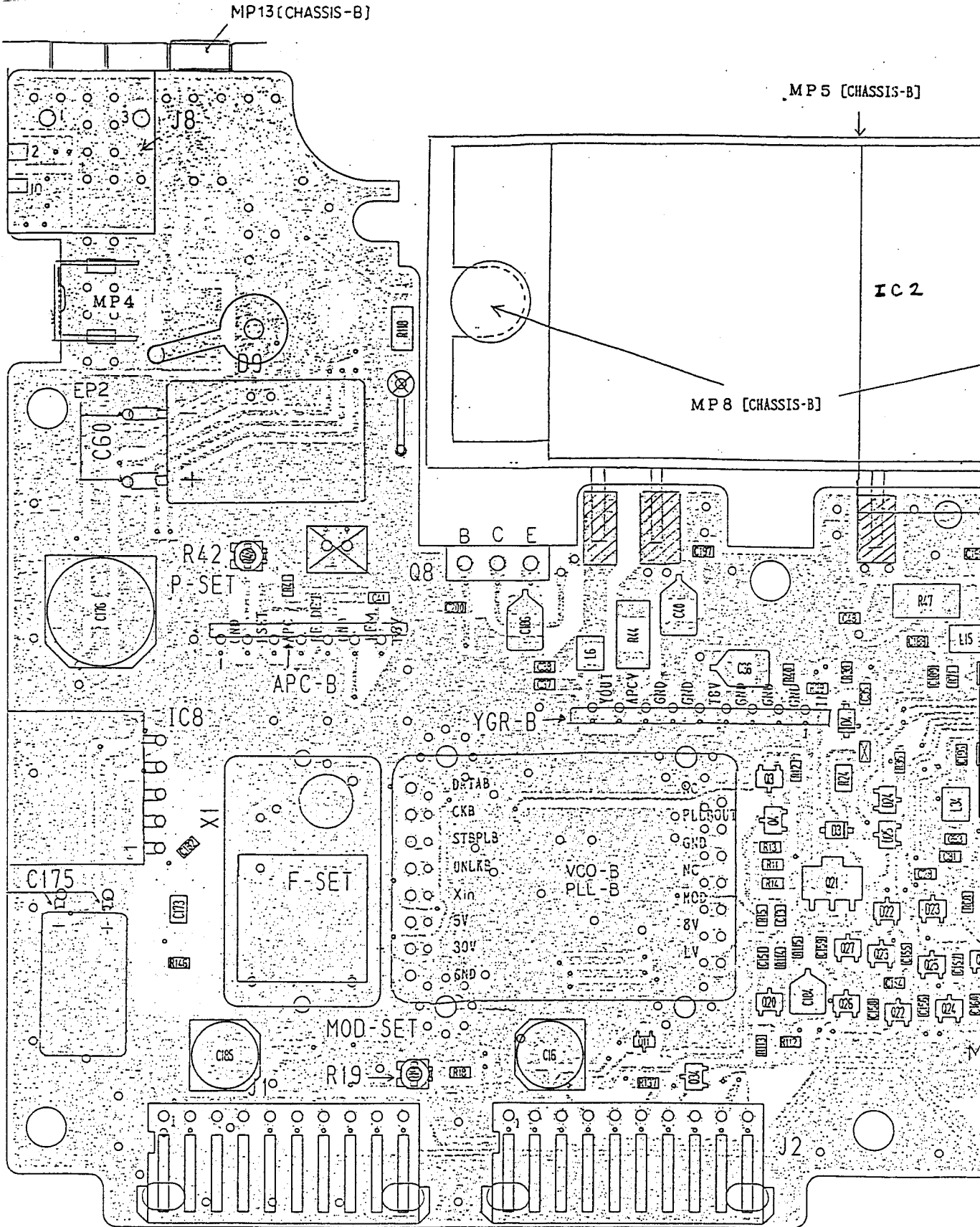

GND  
AFB  
HV  
HV  
FILOB  
30V  
8VB  
MODB  
GND  
DETB

5V  
TEMPB  
SQLB  
S/RFB  
DATA  
CK  
STBPLB  
STBBC  
SPSELB  
UNLKB

CHASSIS-B]

MP 10 [CHASSIS-B]

W4

MP 1 [CHASSIS-B]

IC 2

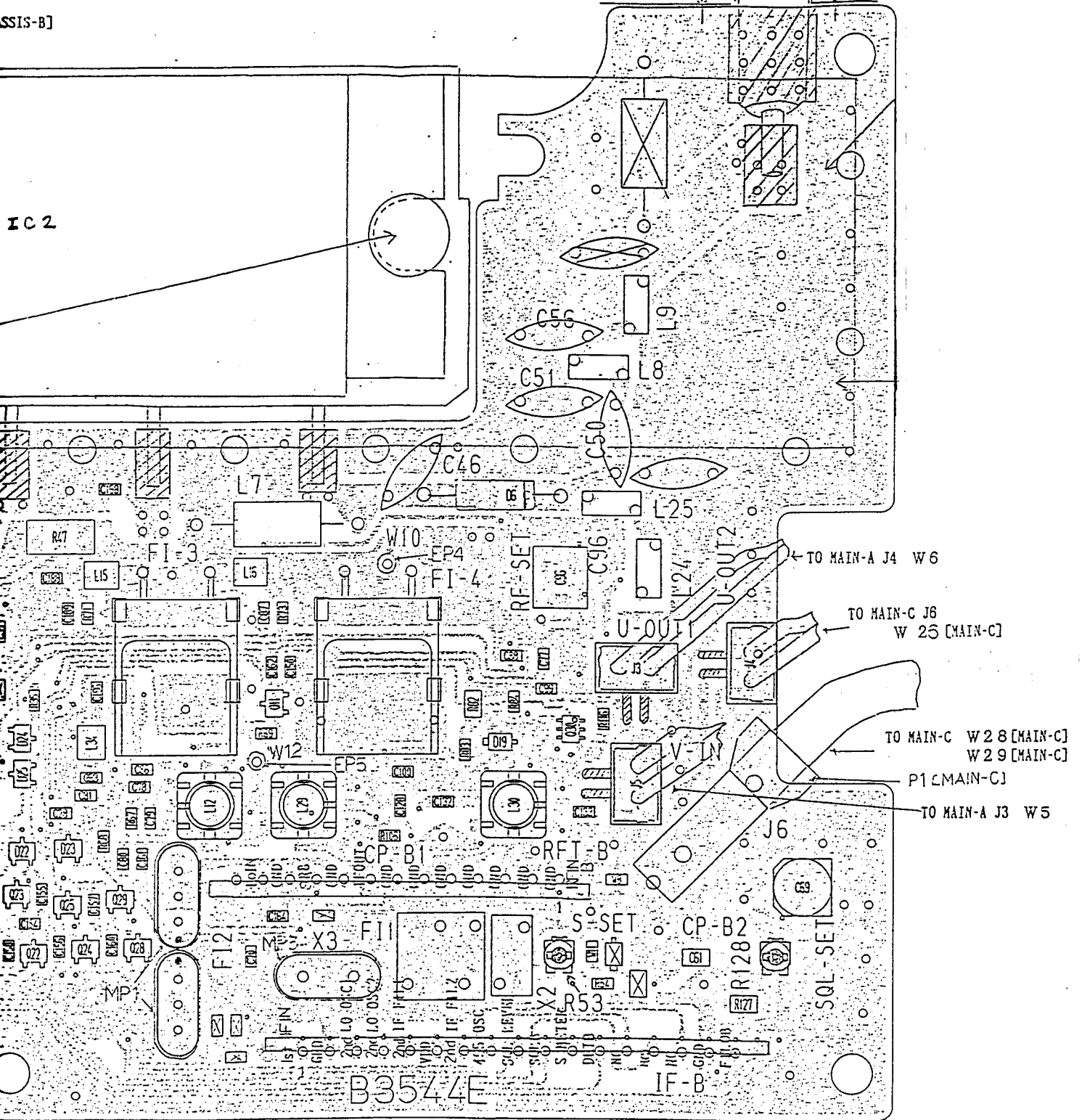

# MAIN-B UNIT

M P 6 [CHASSIS-B]

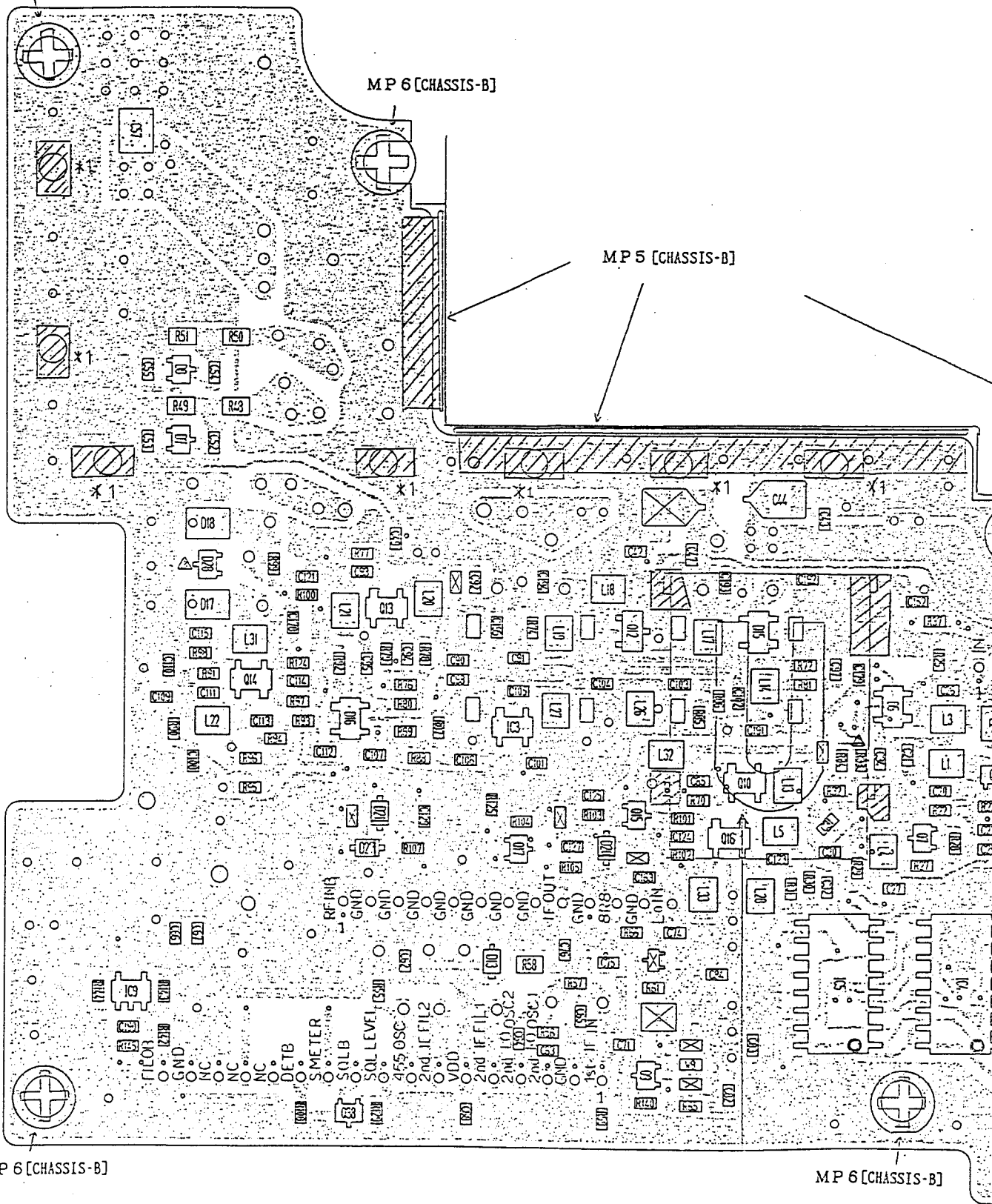

M P 6 [CHASSIS-B]

M P 5 [CHASSIS-B]

M P 6 [CHASSIS-B]

M P 6 [CHASSIS-B]



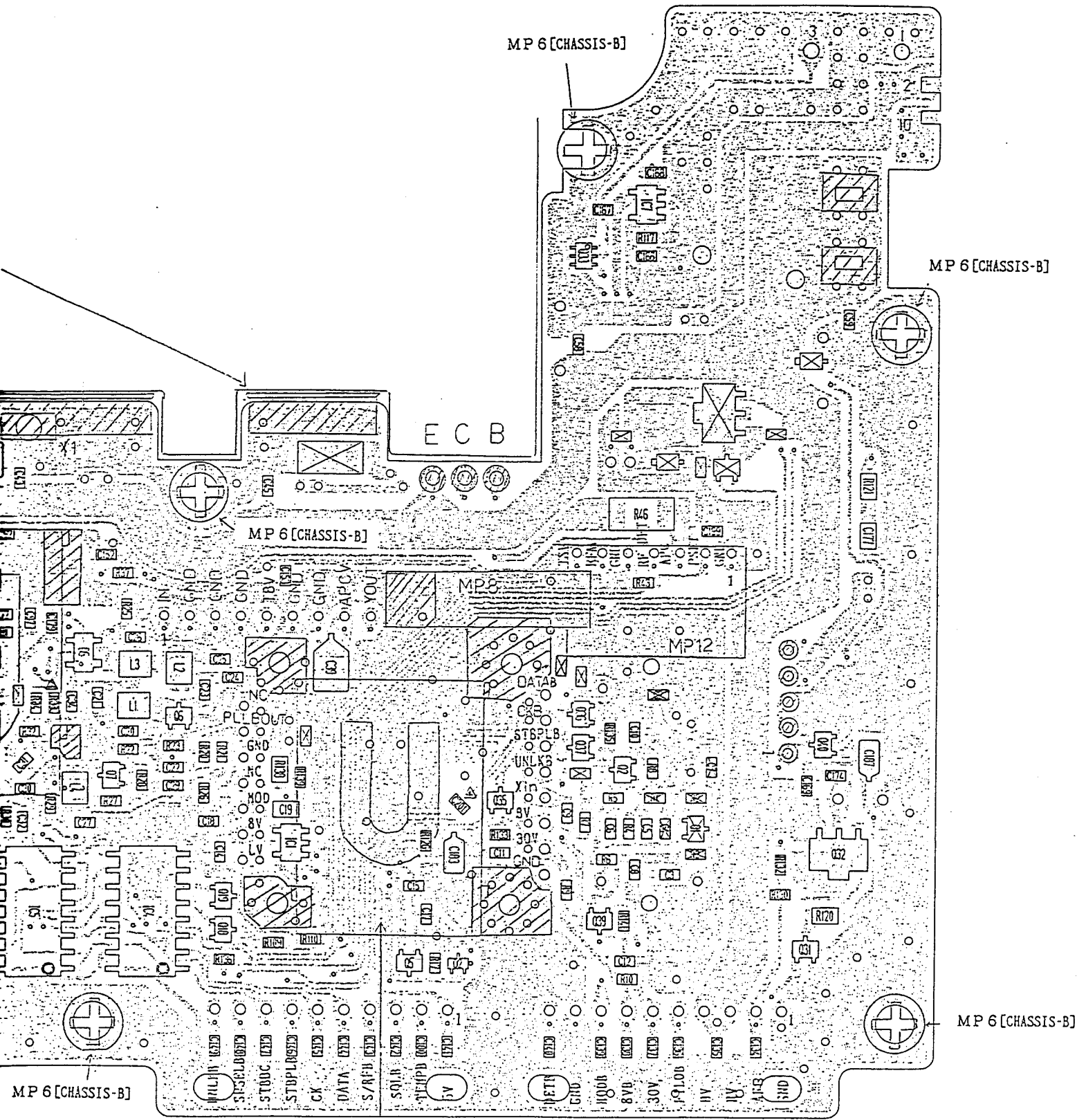

### PLL-B BOARD

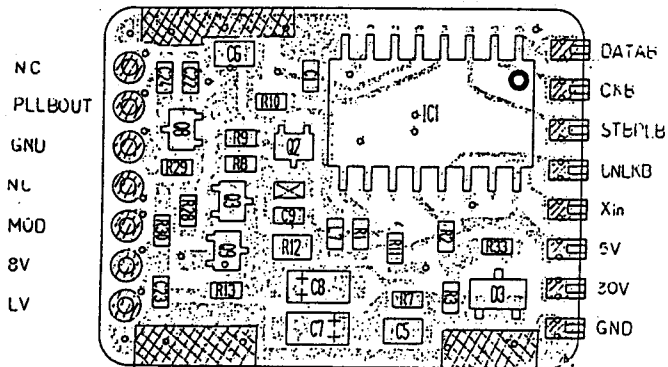

### VCO-B BOARD

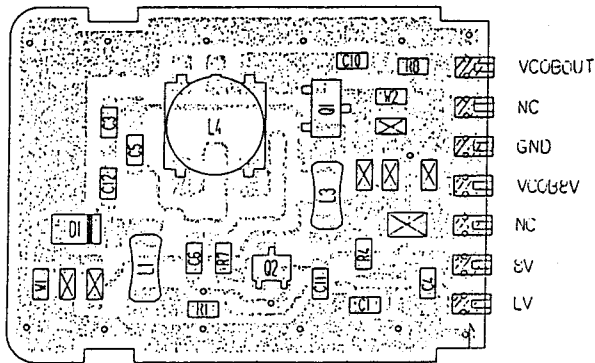

### YGR-B BOARD

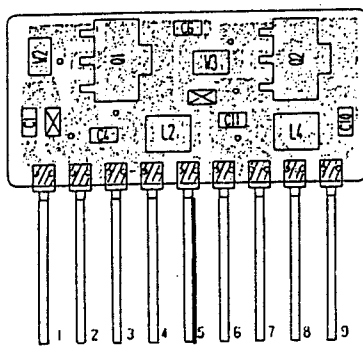

IN  
GND  
GND  
GND  
T8V  
GND  
GND  
APCV  
YOUT

### APC-B BOARD

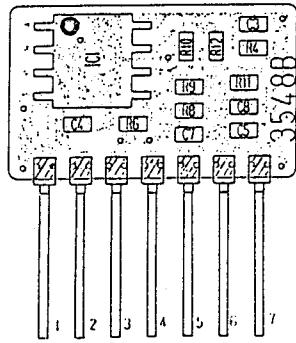

1 GND  
 2 PSET  
 3 APC  
 4 RF DET  
 5 GND  
 6 RFM  
 7 T&V

### IF-B BOARD

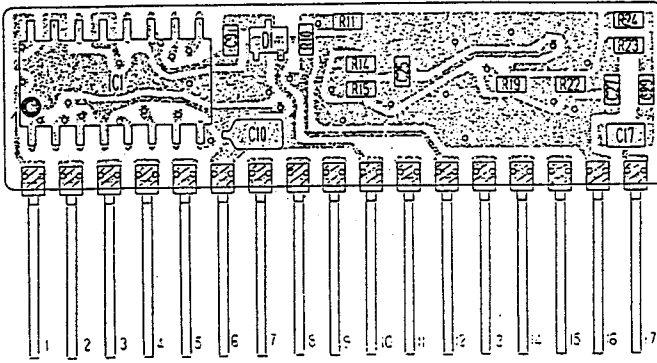

1 1st I/F IN  
 2 GND  
 3 2nd LO OSC 1  
 4 2nd LO OSC 2  
 5 2nd I/F FIL 1  
 6 VDD  
 7 2nd I/F FIL 2  
 8 455 OSC  
 9 SQL LEVEL  
 10 SQL B  
 11 SMETER  
 12 DET B  
 13 NC  
 14 NC  
 15 NC  
 16 GND  
 17 FILOB

### RFT-B BOARD

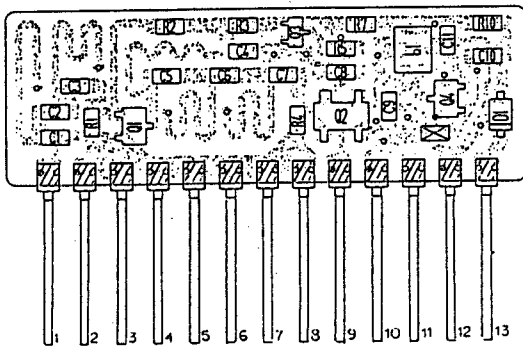

1 RFINE  
 2 GND  
 3 GND  
 4 GND  
 5 GND  
 6 GND  
 7 GND  
 8 GND  
 9 IF OUT  
 10 GND  
 11 SFE  
 12 GND  
 13 LoIN

### APC-B BOARD

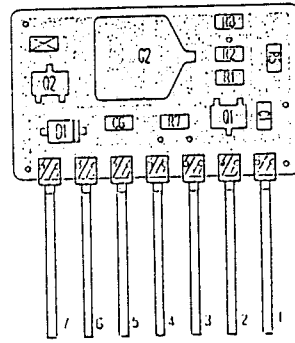

1 TSV  
 2 RFM  
 3 GND  
 4 RF DET  
 5 APC  
 6 PSET  
 7 GND

### IF-B BOARD

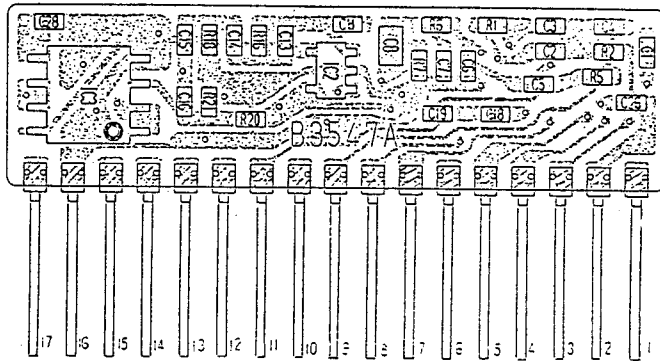

1 FILOB  
 2 GND  
 3 NC  
 4 NC  
 5 NC  
 6 DETB  
 7 SMETER  
 8 SQLB  
 9 SQL LEVEL  
 10 455OSC  
 11 2ndIF FIL2  
 12 VDD  
 13 2ndIF FIL1  
 14 2ndLOOSC2  
 15 2ndLOOSC1  
 16 GND  
 17 1stIFIN

### RFT-B BOARD

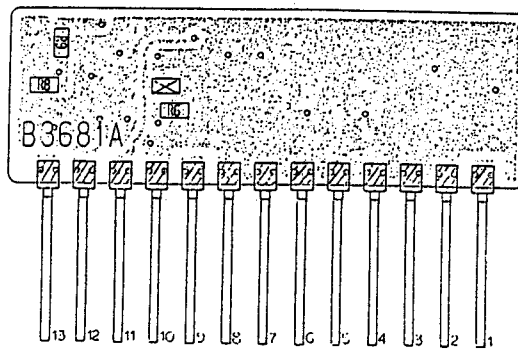

1 LFN  
 2 GND  
 3 SFE  
 4 GND  
 5 IFOUT  
 6 GND  
 7 GND  
 8 GND  
 9 GND  
 10 GND  
 11 GND  
 12 GND  
 13 FFINE

### PLL-B BOARD

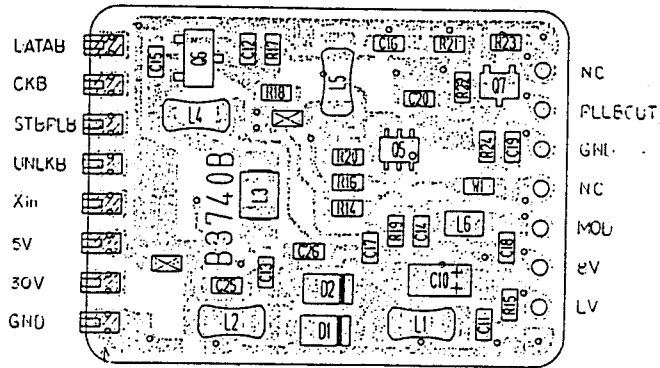

### VCO-B BOARD

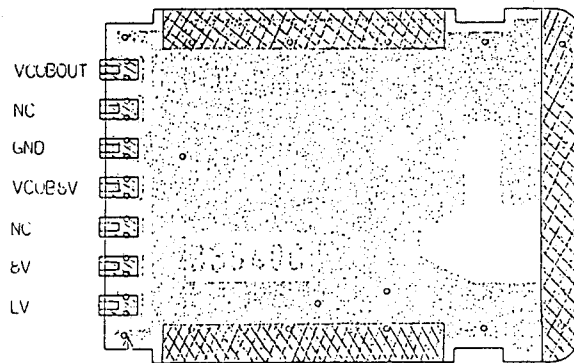

### YGR-B BOARD

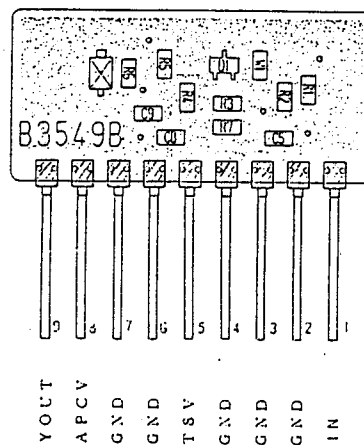

# MAIN-C UNIT

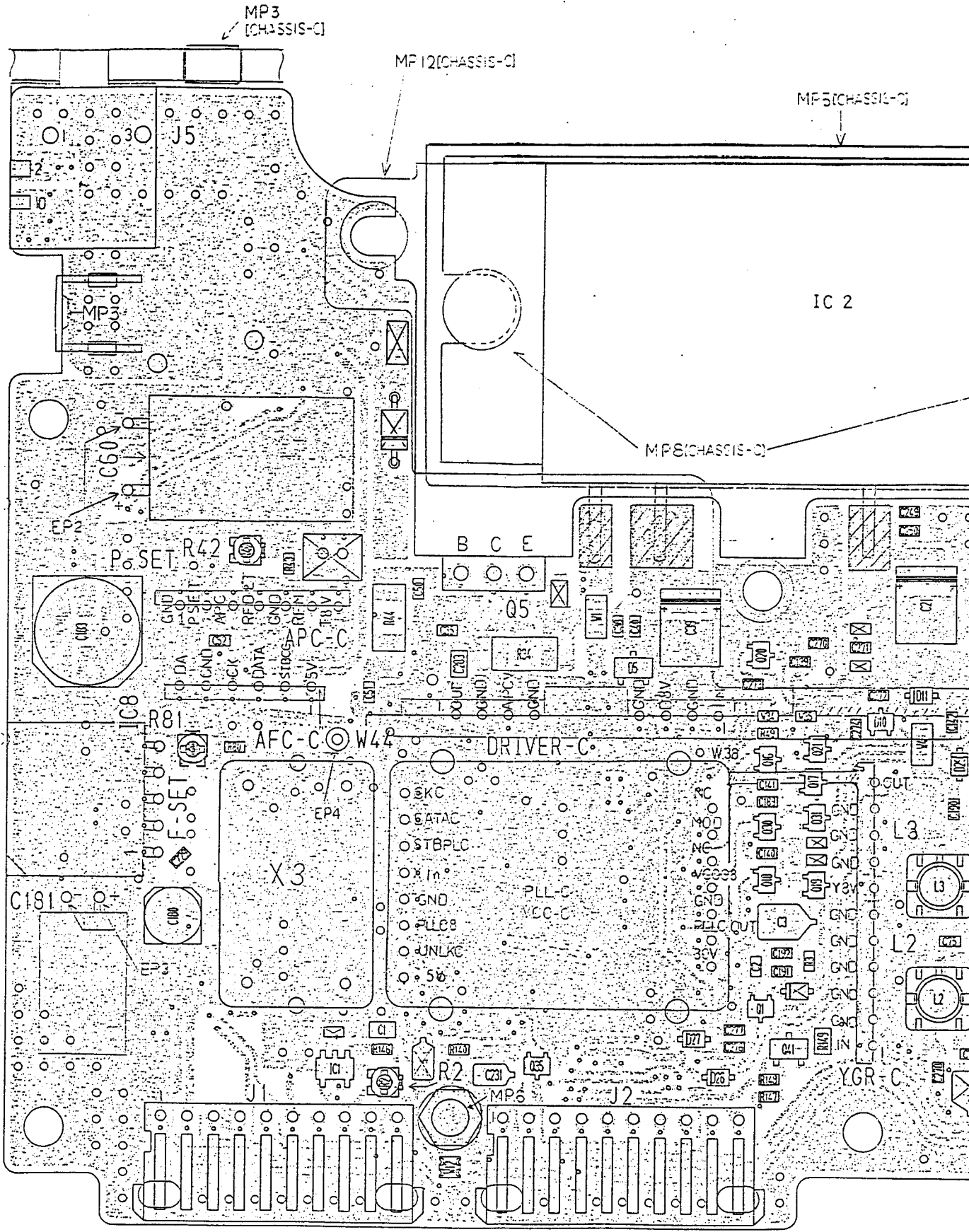

- |        |        |
|--------|--------|
| GND    | 5V     |
| AFC    | NC     |
| HV     | SQLC   |
| HV     | S/RFC  |
| FILEOC | DATA   |
| 30V    | CK     |
| 8VC    | STBPLC |
| MODC   | STBCC  |
| GND    | SPSELC |
| DETC   | UNLKC  |

45916-C1

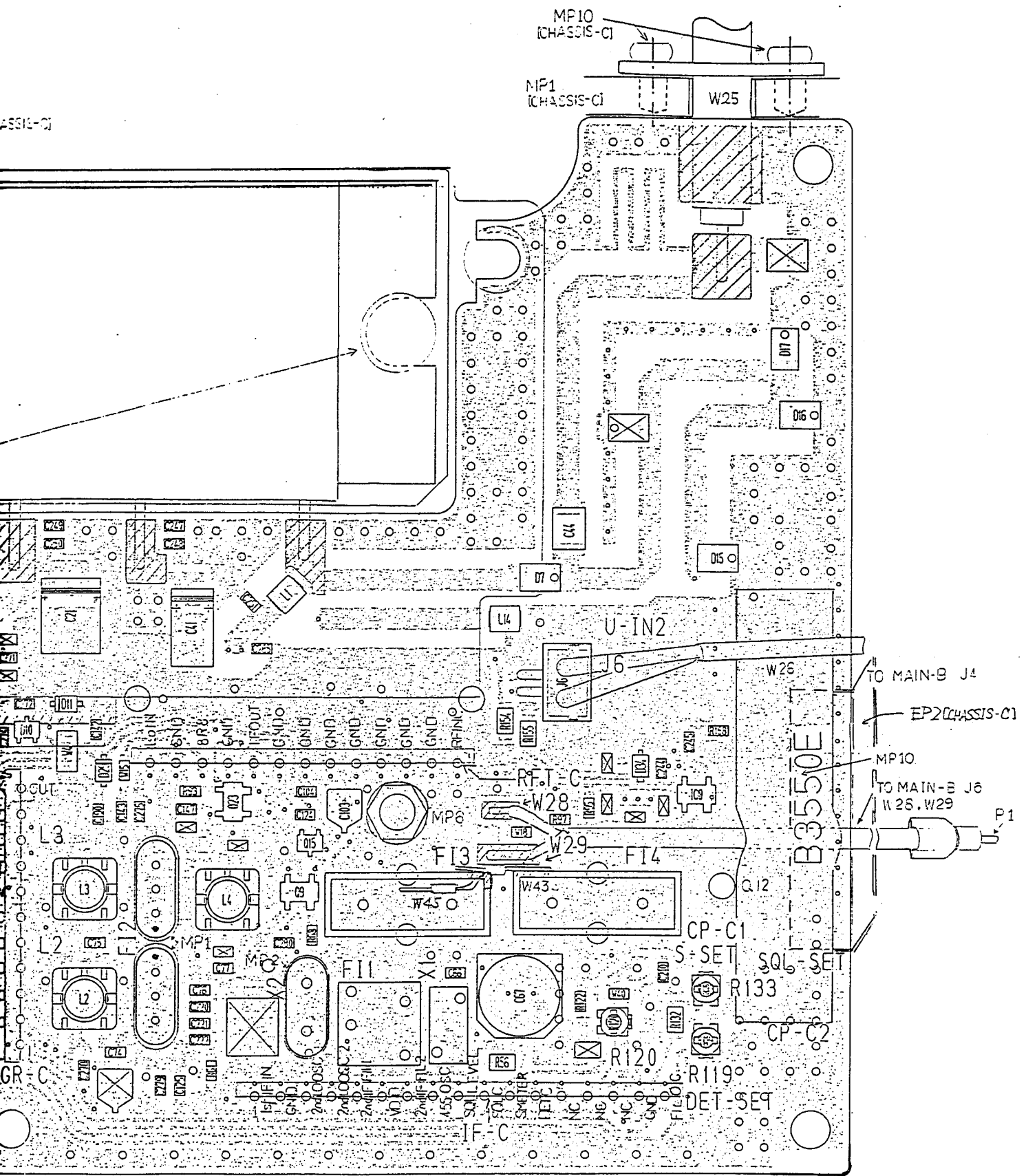

# MAIN-C UNIT

MP1  
[CHASSIS-C]

MP 6 [CHASSIS-C]

MP 6 [CHASSIS-C]

MP5 (CHASSIS-C)

MP

EP1  
[CHASSIS-C]

MP 6 [CHASSIS-C]

MP 6 [CHASSIS-C]

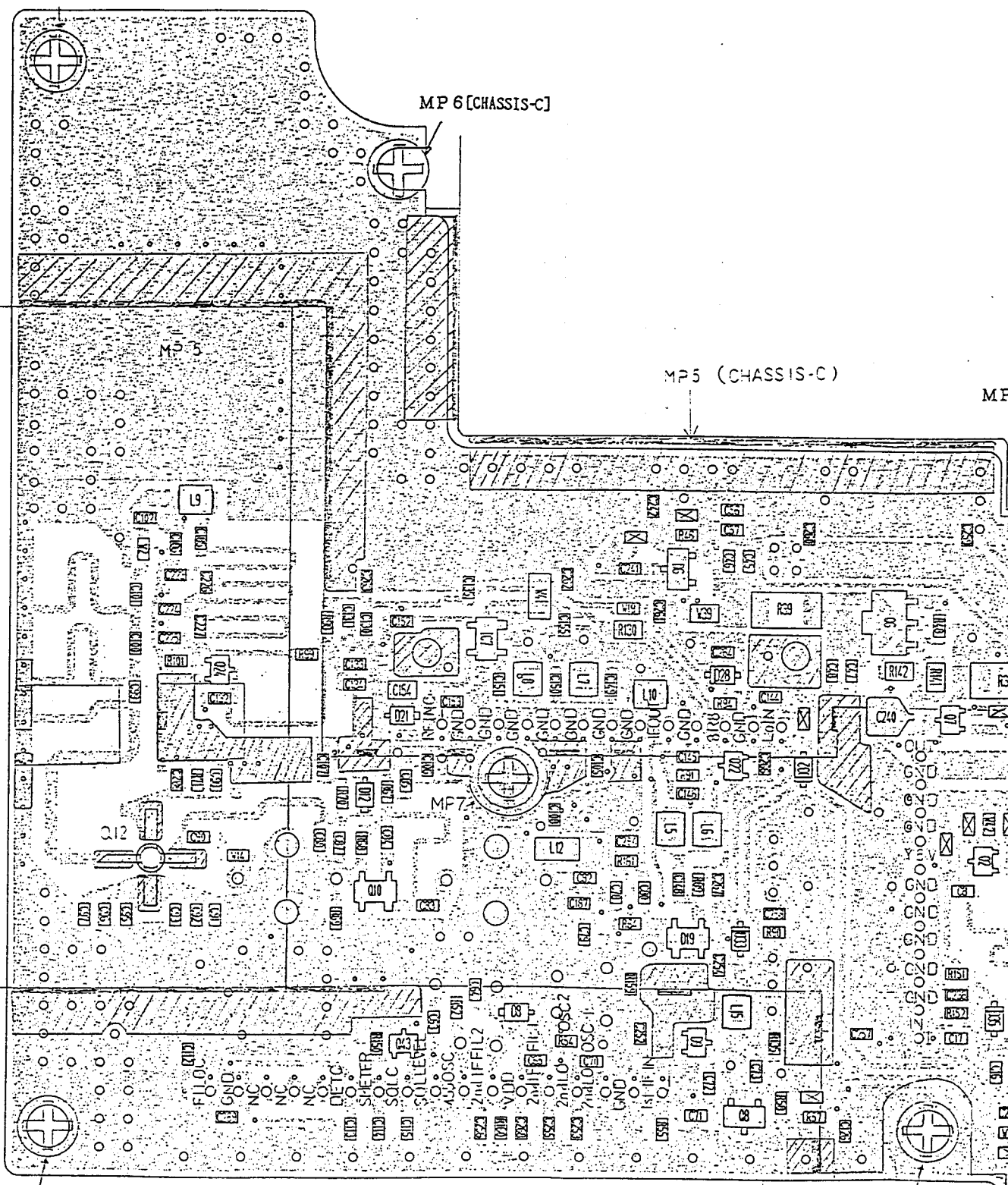



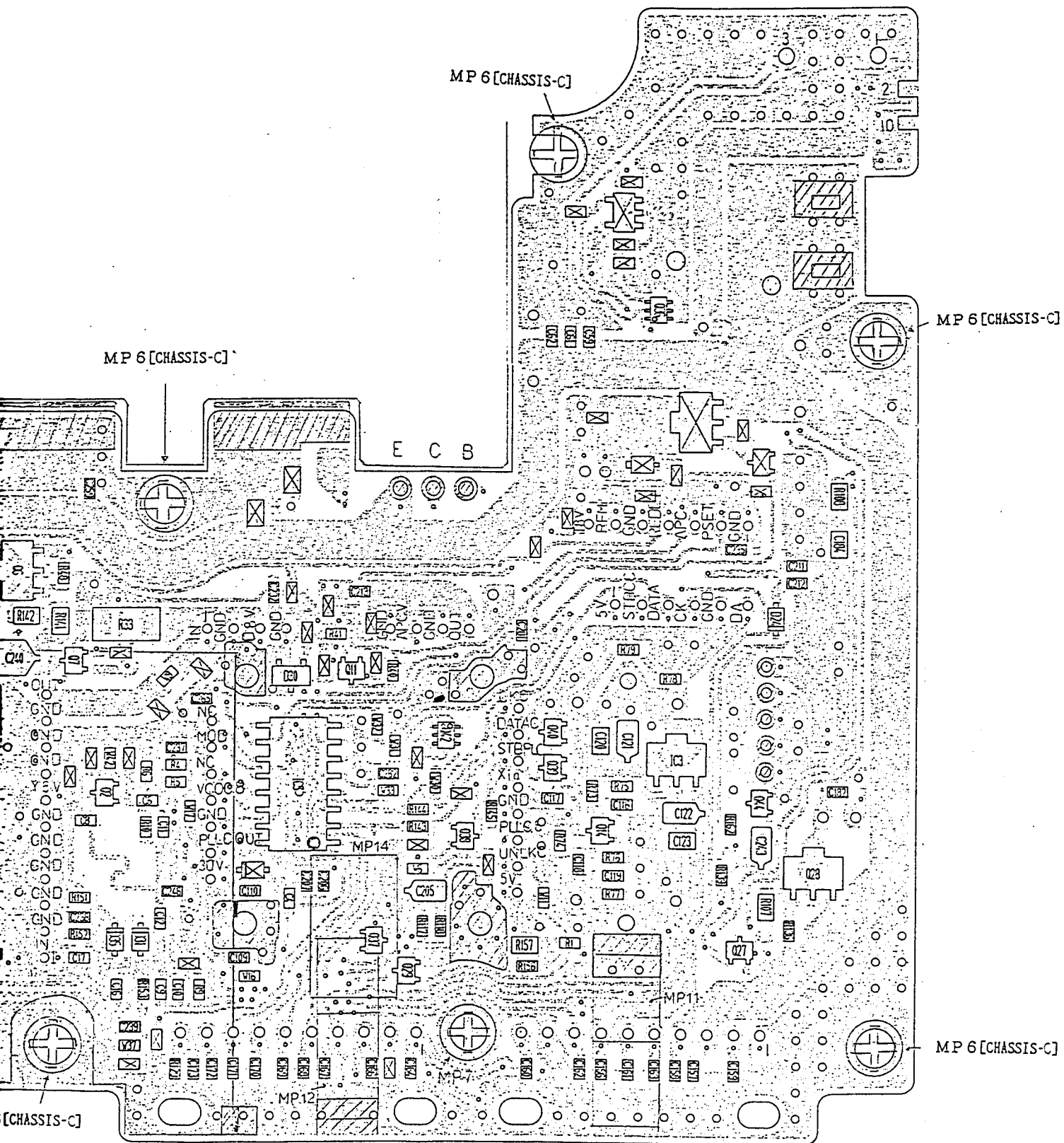

- UNLKC
- SPSELC
- STBCC
- STRPLC
- CK
- DATA
- S/RFC
- SQLC
- NC
- 5V
- DETC
- GND
- MODC
- 8VC
- 30V
- FILLOC
- HV
- HV
- AFC
- GND

### PLL-C BOARD

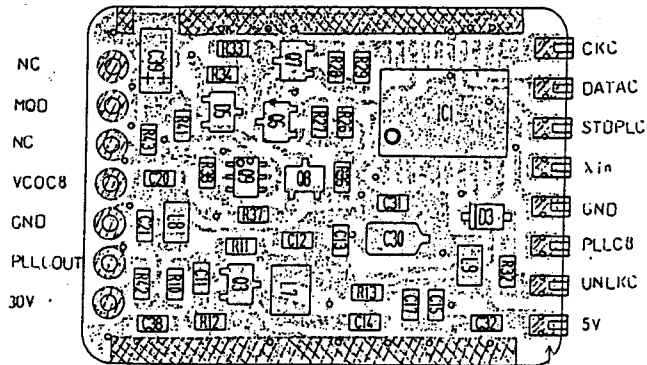

### VCO-C BOARD

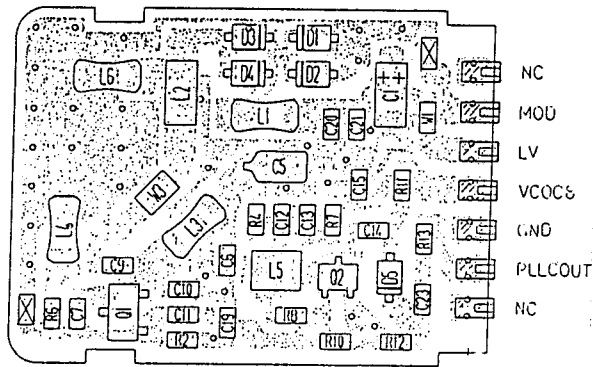

### YGR-C BOARD

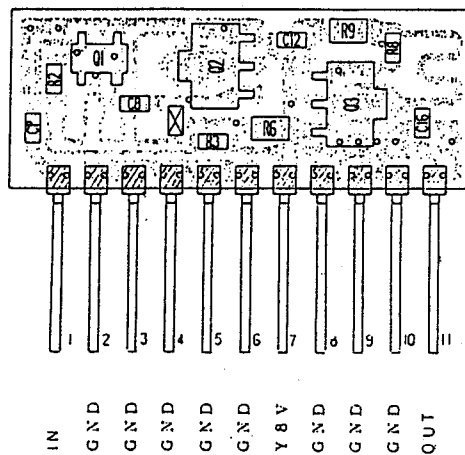

### DRIVER-C BOARD

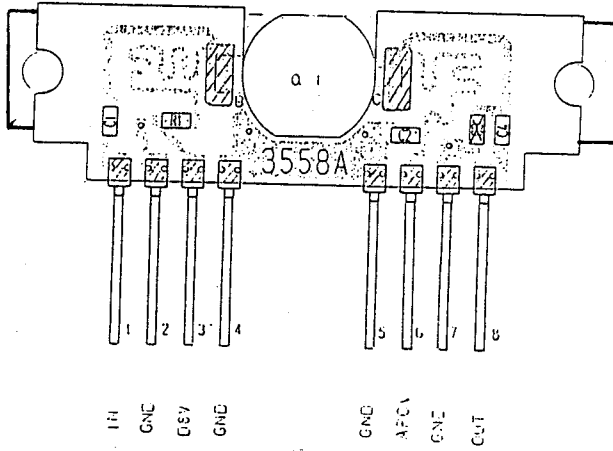

### APC-C BOARD

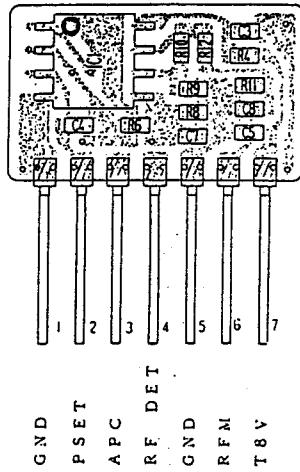

### IF-C BOARD

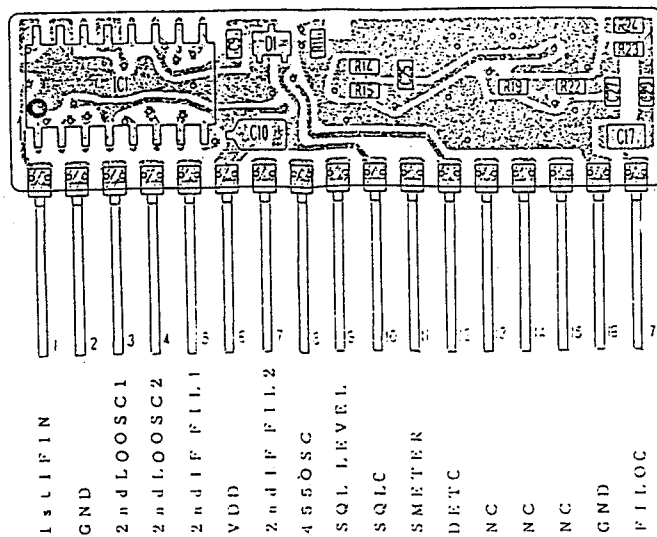

### DRIVER-C BOARD

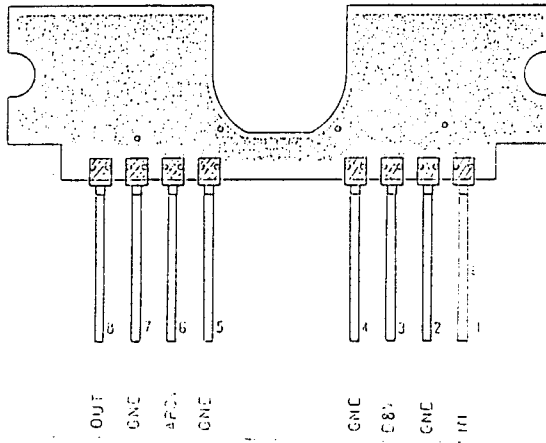

### APC-C BOARD

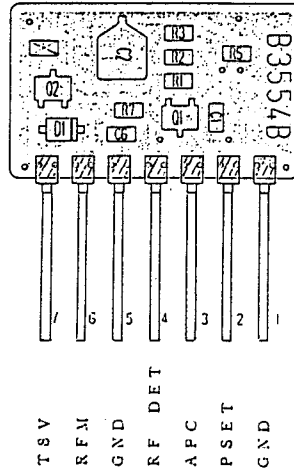

### IF-C BOARD

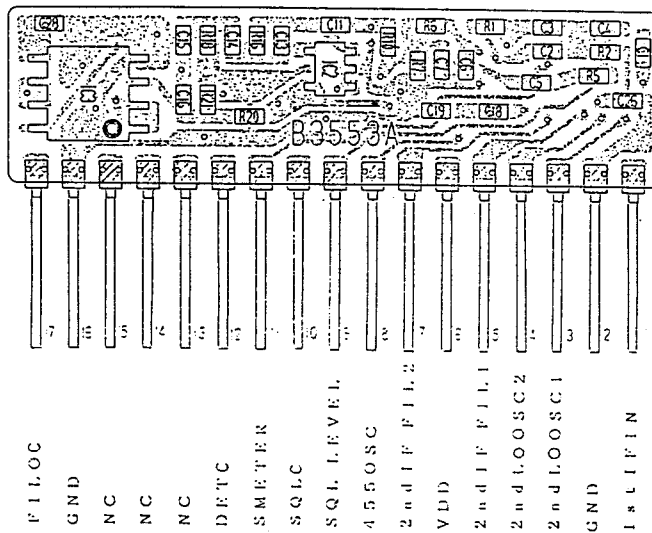

### PLL-C BOARD

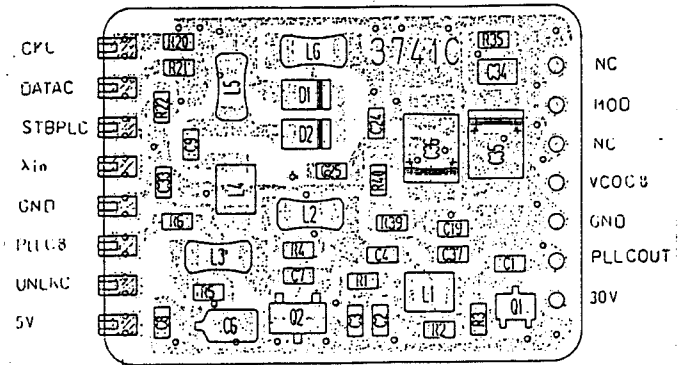

### VCO-C BOARD

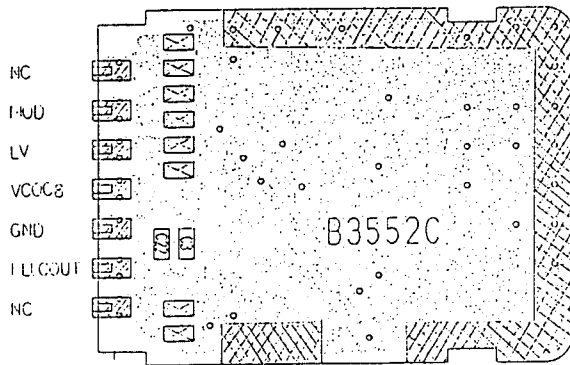

### YGR-C BOARD

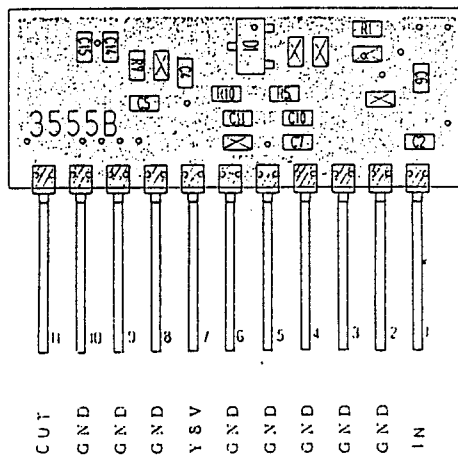

### RFT-C BOARD

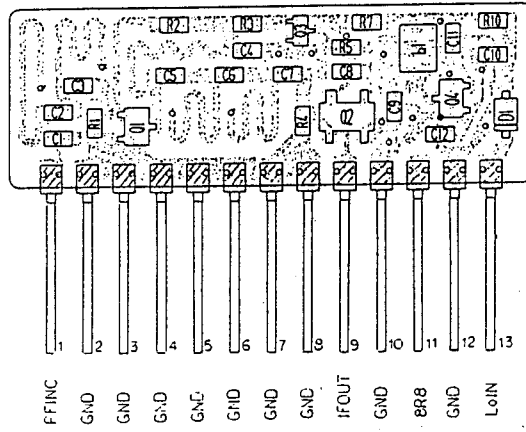

### AFC-C BOARD

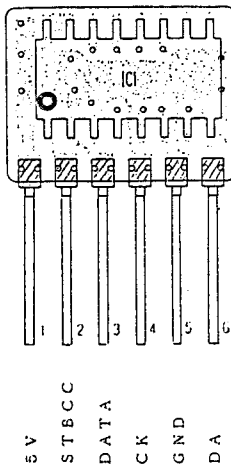

### RFT-C BOARD

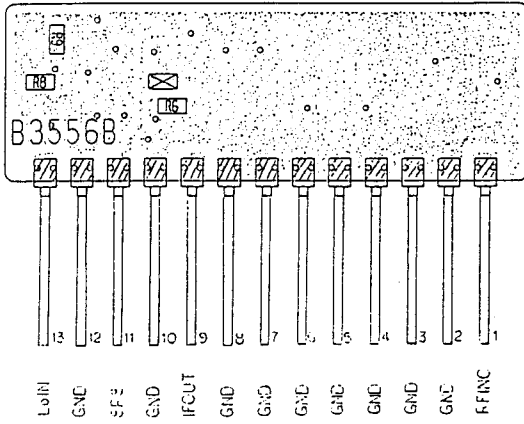

### AFC-C BOARD

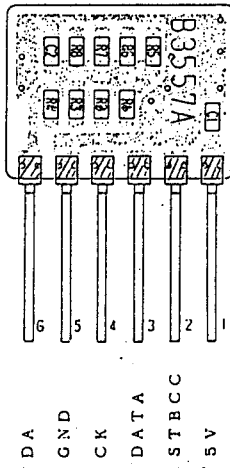

# DISASSEMBLY

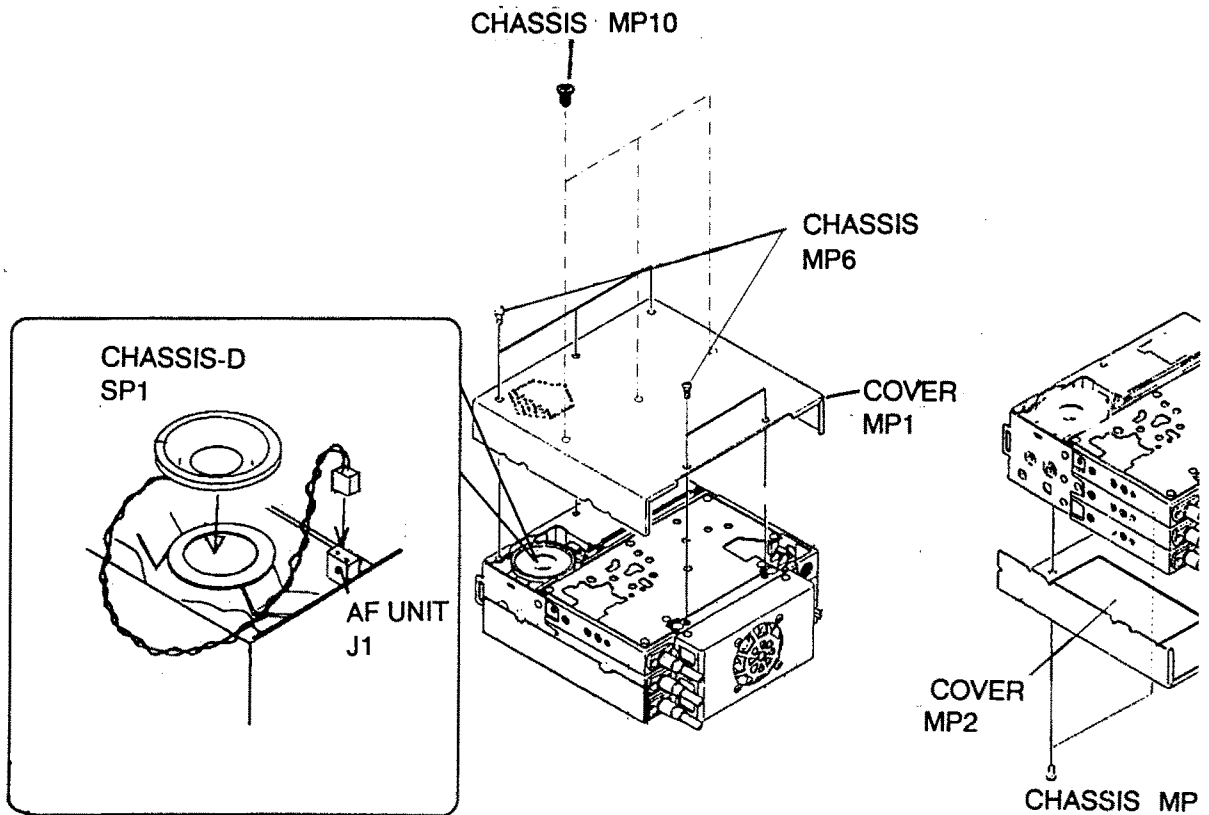
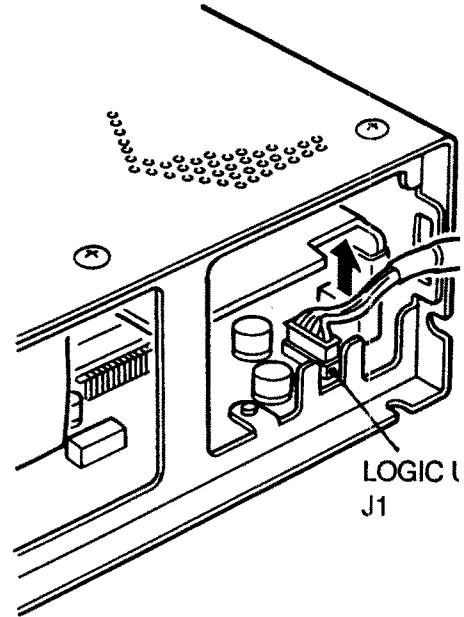
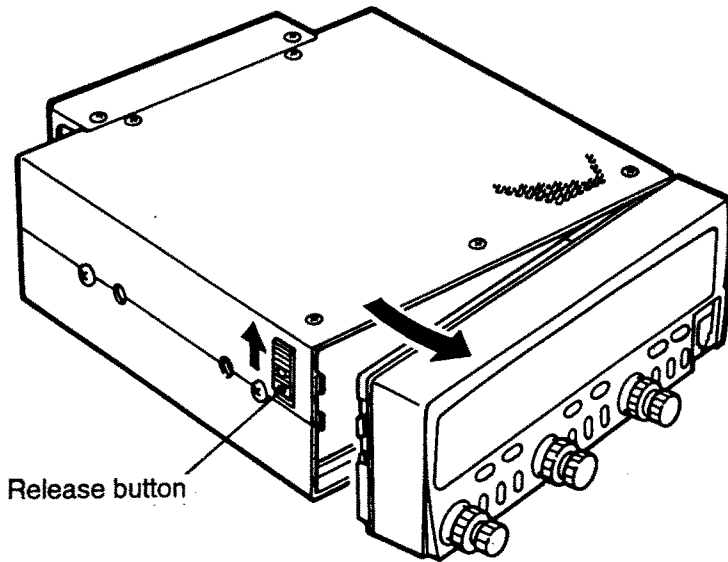



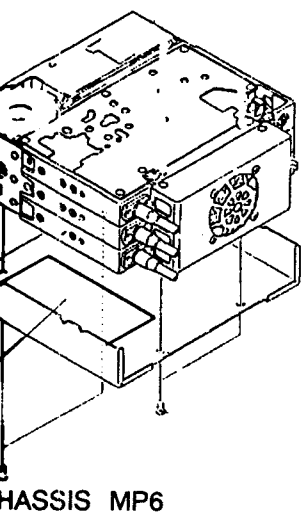
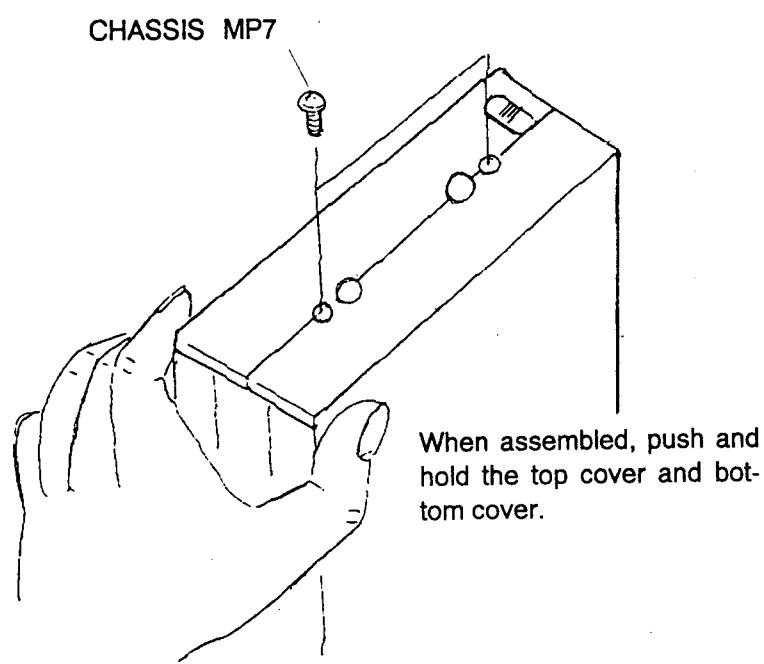
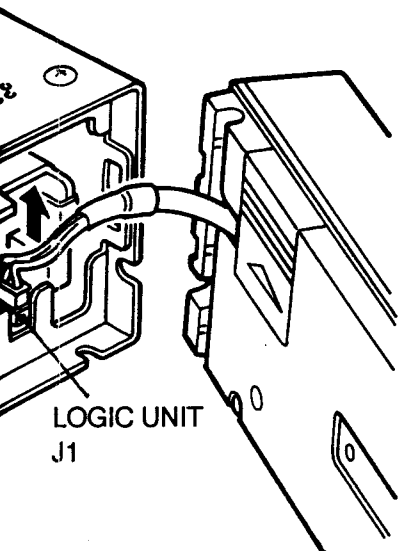

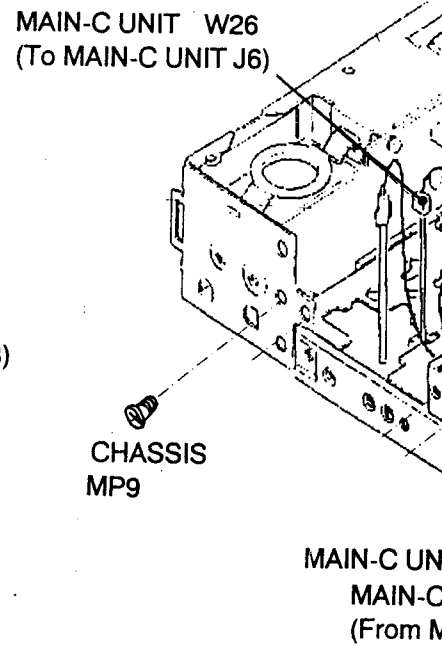
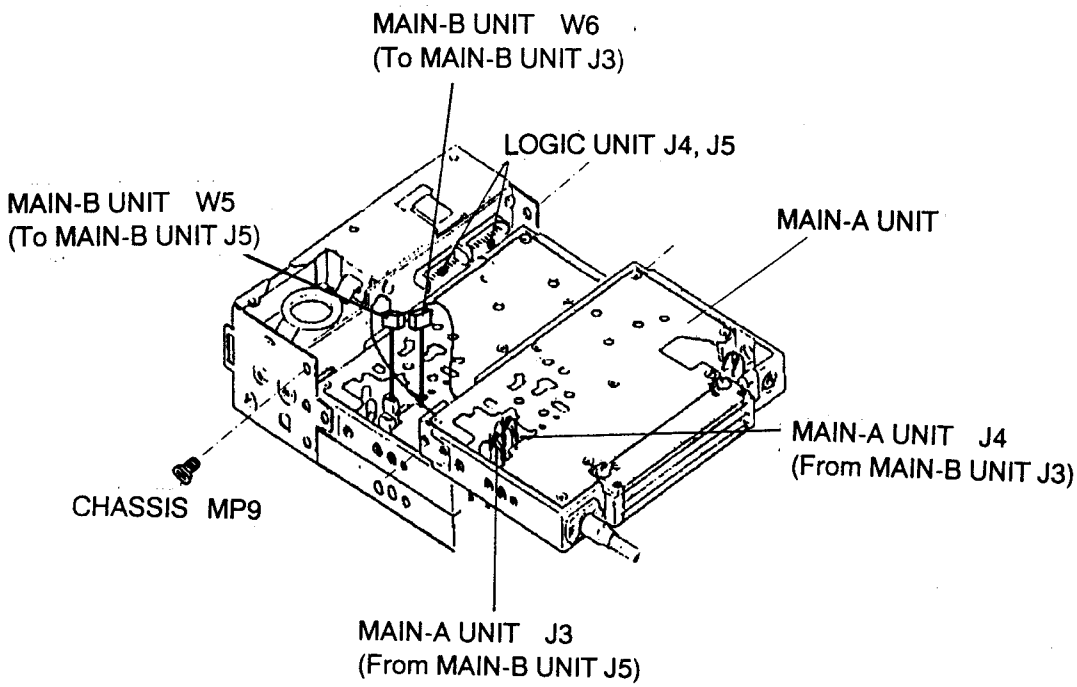
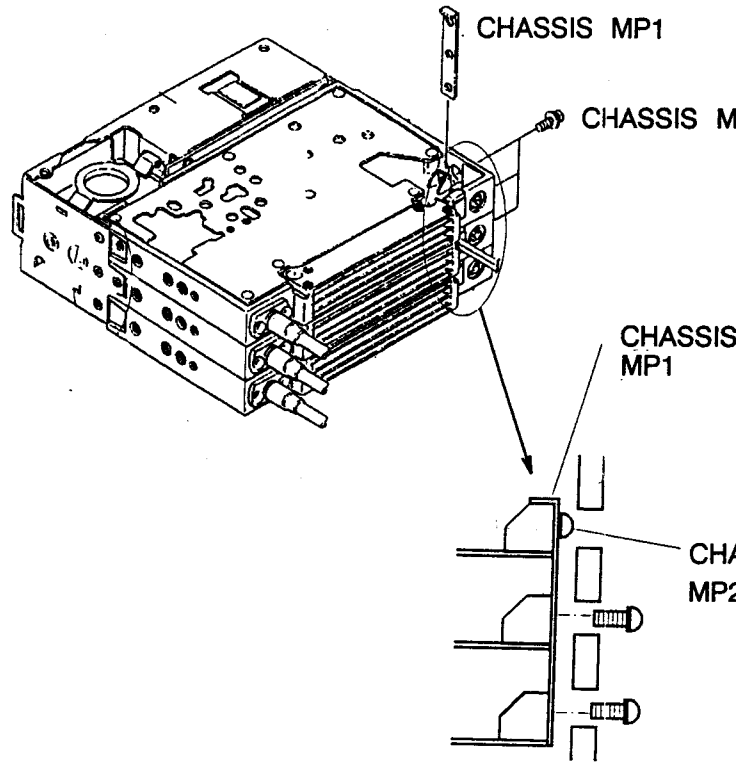
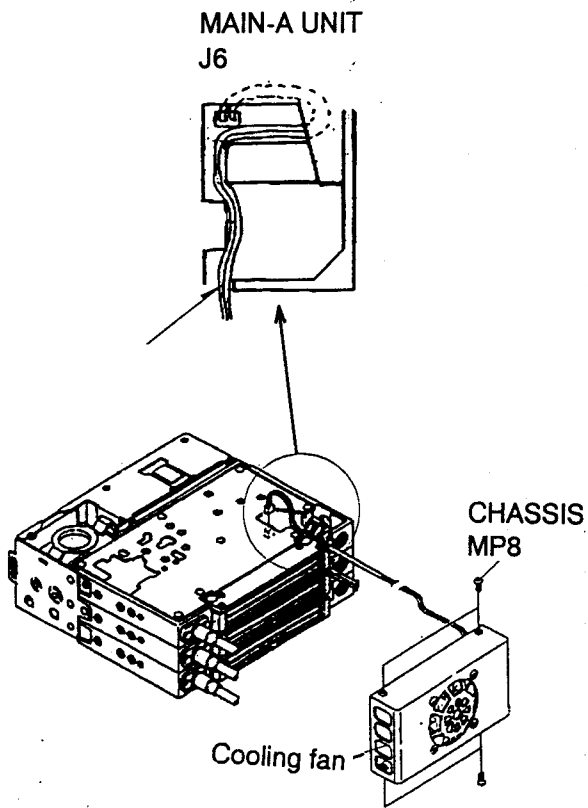

IS MP1

CHASSIS MP2

CHASSIS MP1

CHASSIS MP2

CHASSIS MP4

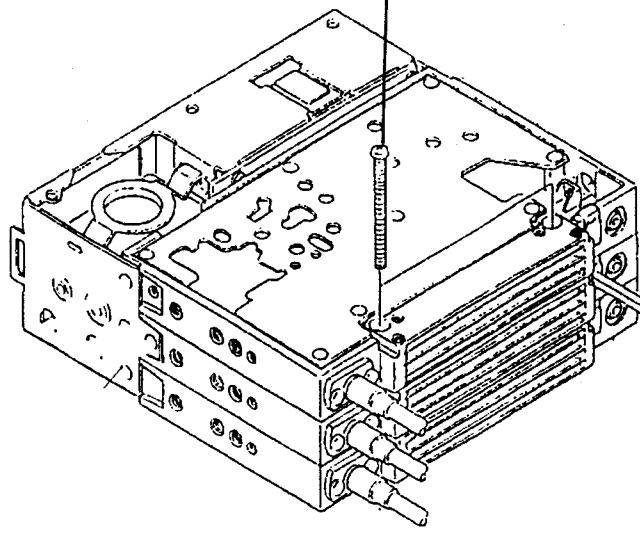

LOGIC UNIT J6, J7

MAIN-B UNIT W5  
(From MAIN-A UNIT J3)

MAIN-B UNIT W6  
(To MAIN-A UNIT J4)

MAIN-B UNIT

MAIN-B UNIT W5  
(To MAIN-A UNIT J3)

MAIN-C UNIT W28, W29  
MAIN-C UNIT W26  
(From MAIN-C UNIT J6)

MAIN-B UNIT W6  
(From MAIN-A UNIT J4)

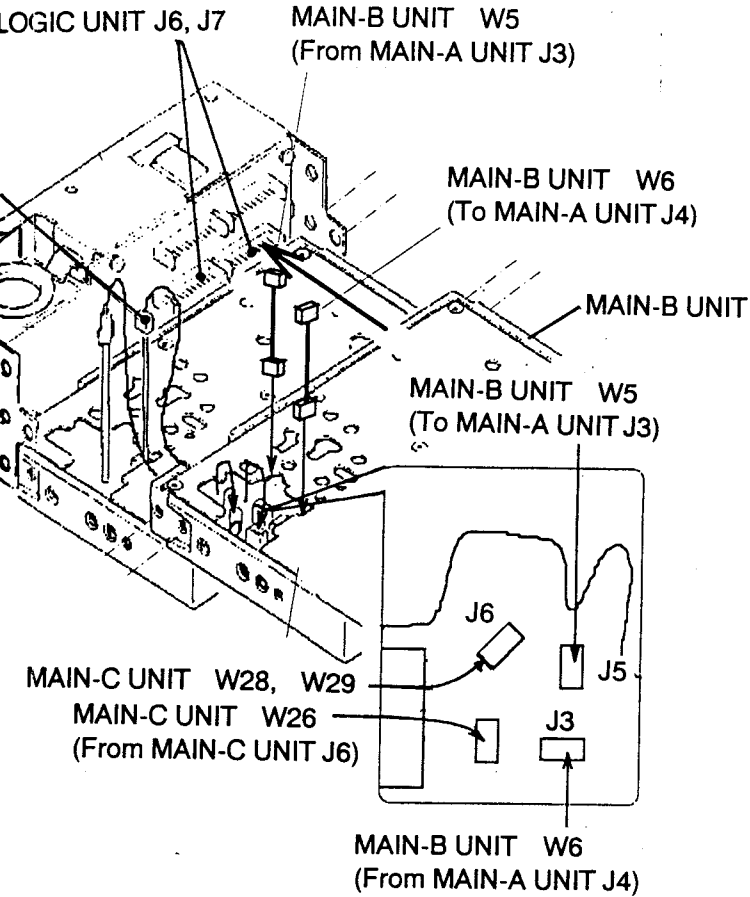

CHASSIS-D MP1

CHASSIS MP9

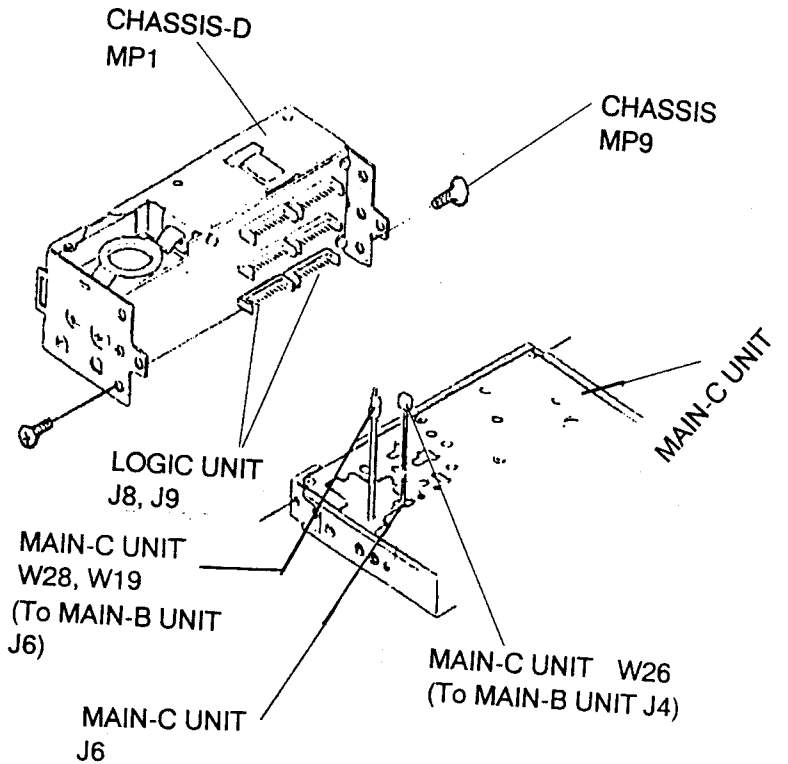

CHASSIS-A, CHASSIS-B or CHASSIS-C  
MP6

MAIN-A UNIT, MAIN-B UNIT  
or MAIN-C UNIT

CHASSIS-A, CHASSIS-  
B or CHASSIS-C MP1

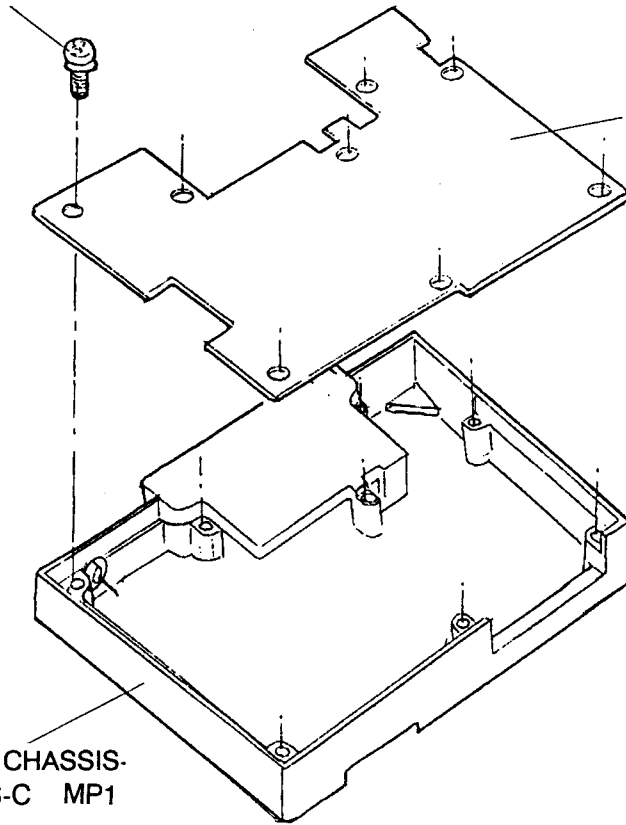

FRONT MP28

FRONT MP3

FRONT  
W1

FRONT MP32

J2

When MP28's are tightened,  
push these positions.

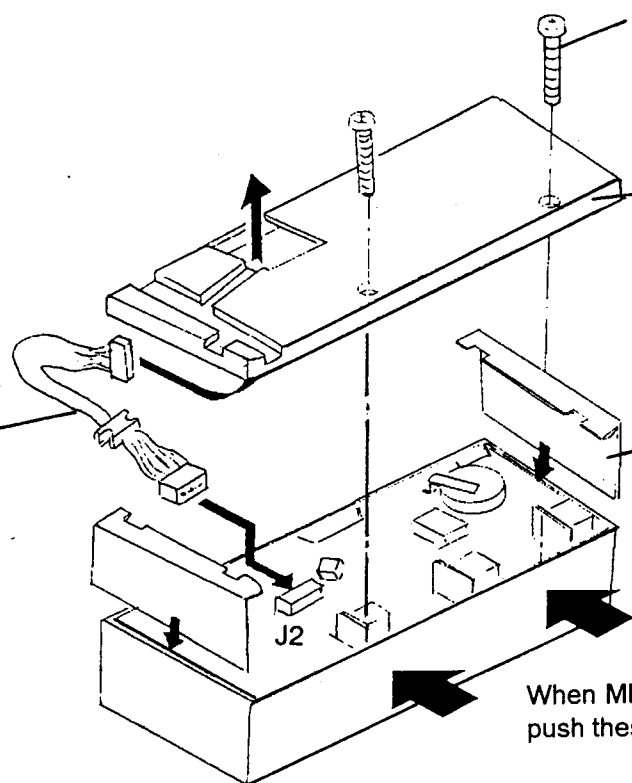

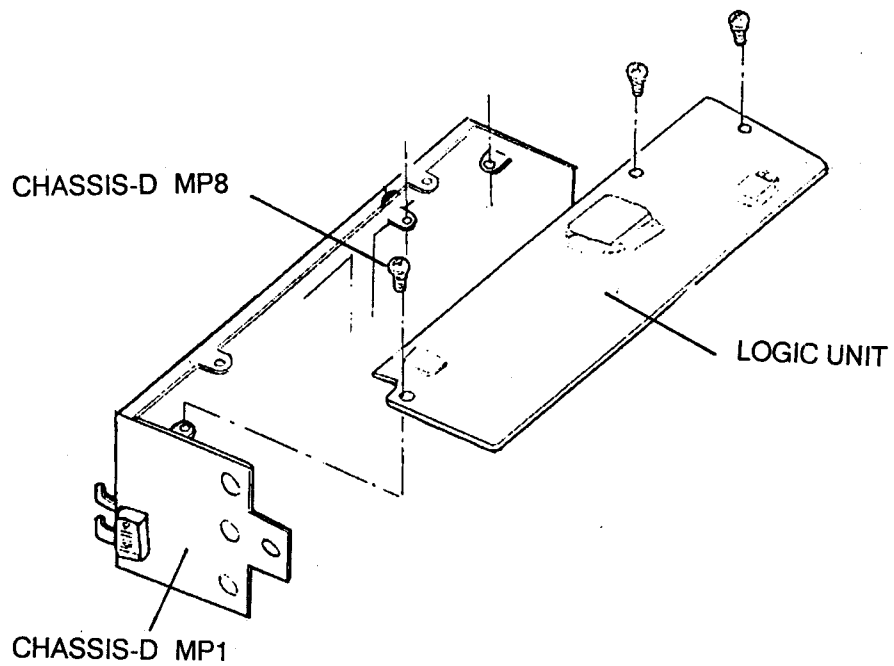
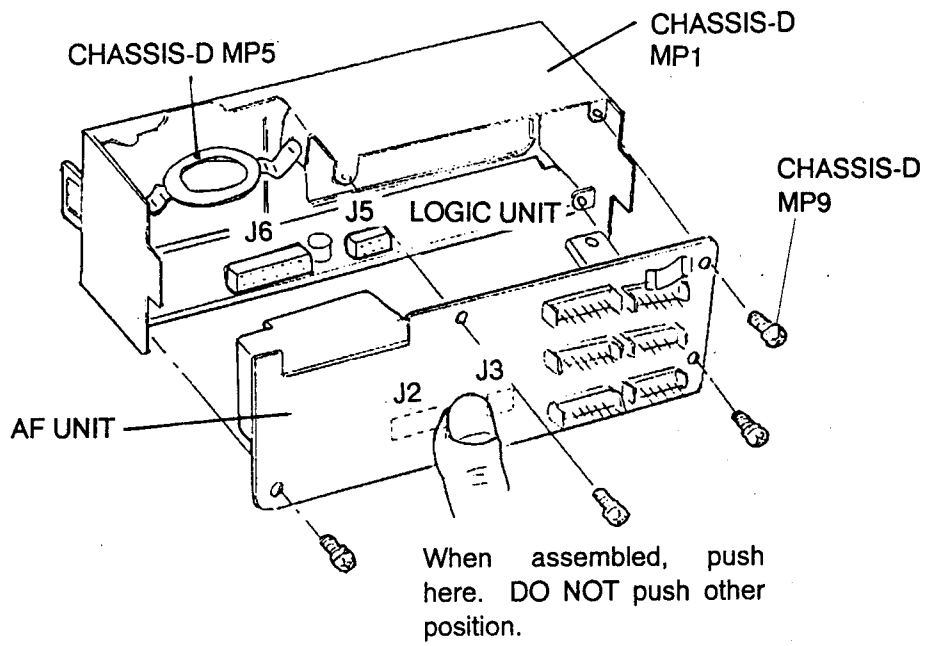

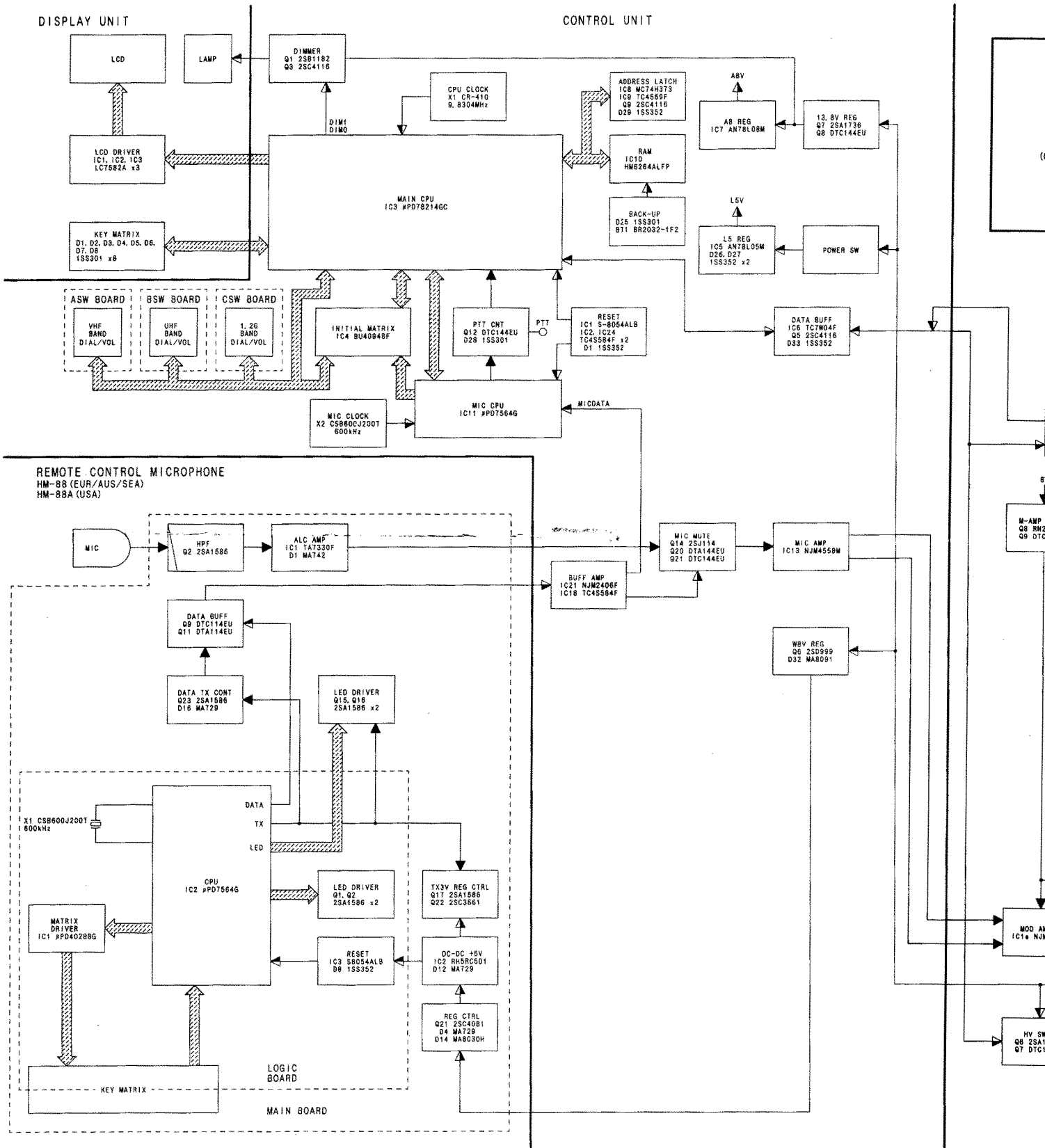

# OOH

## BLOCK DIAGRAM

CONTROL UNIT

LOGIC

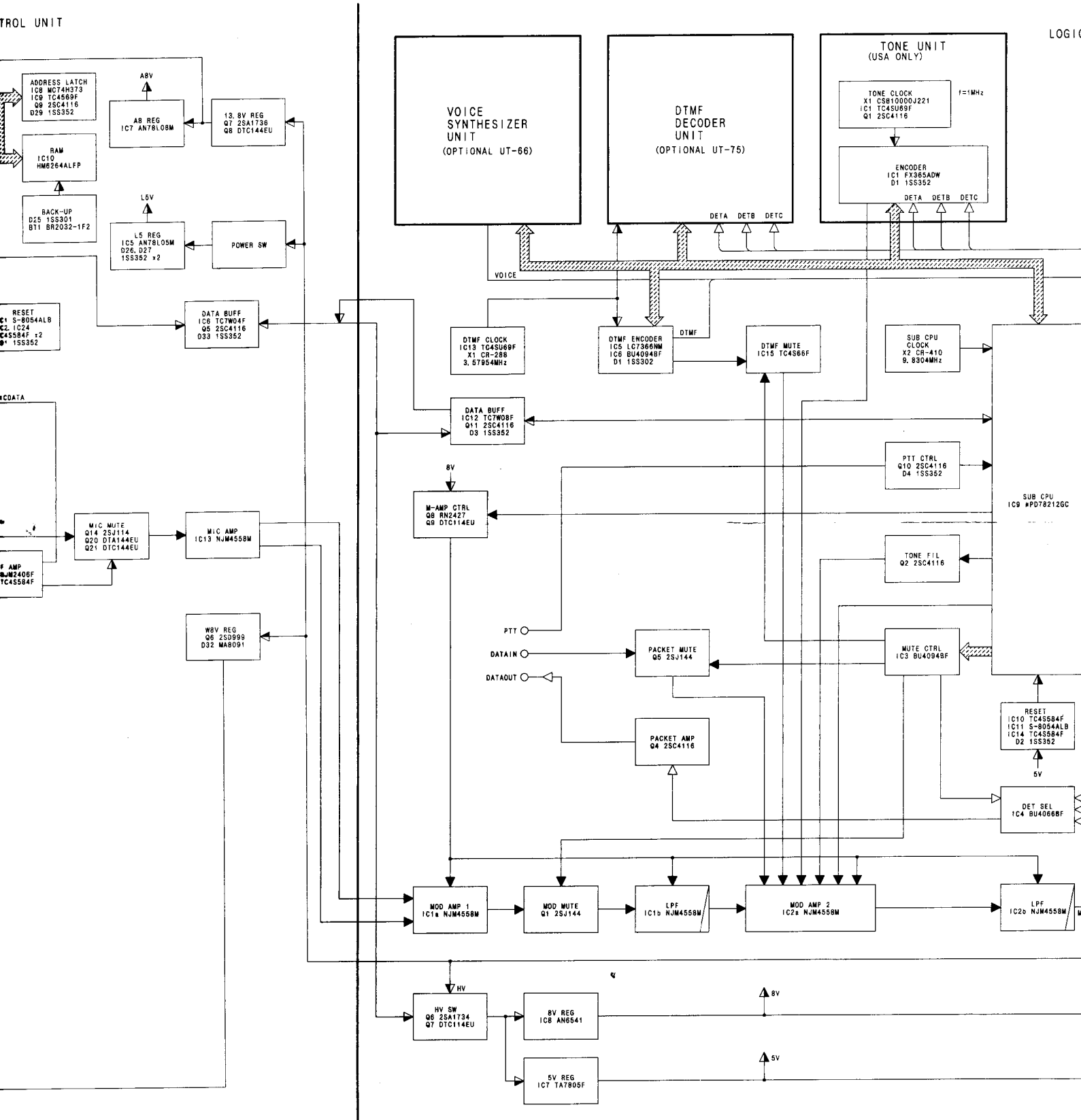

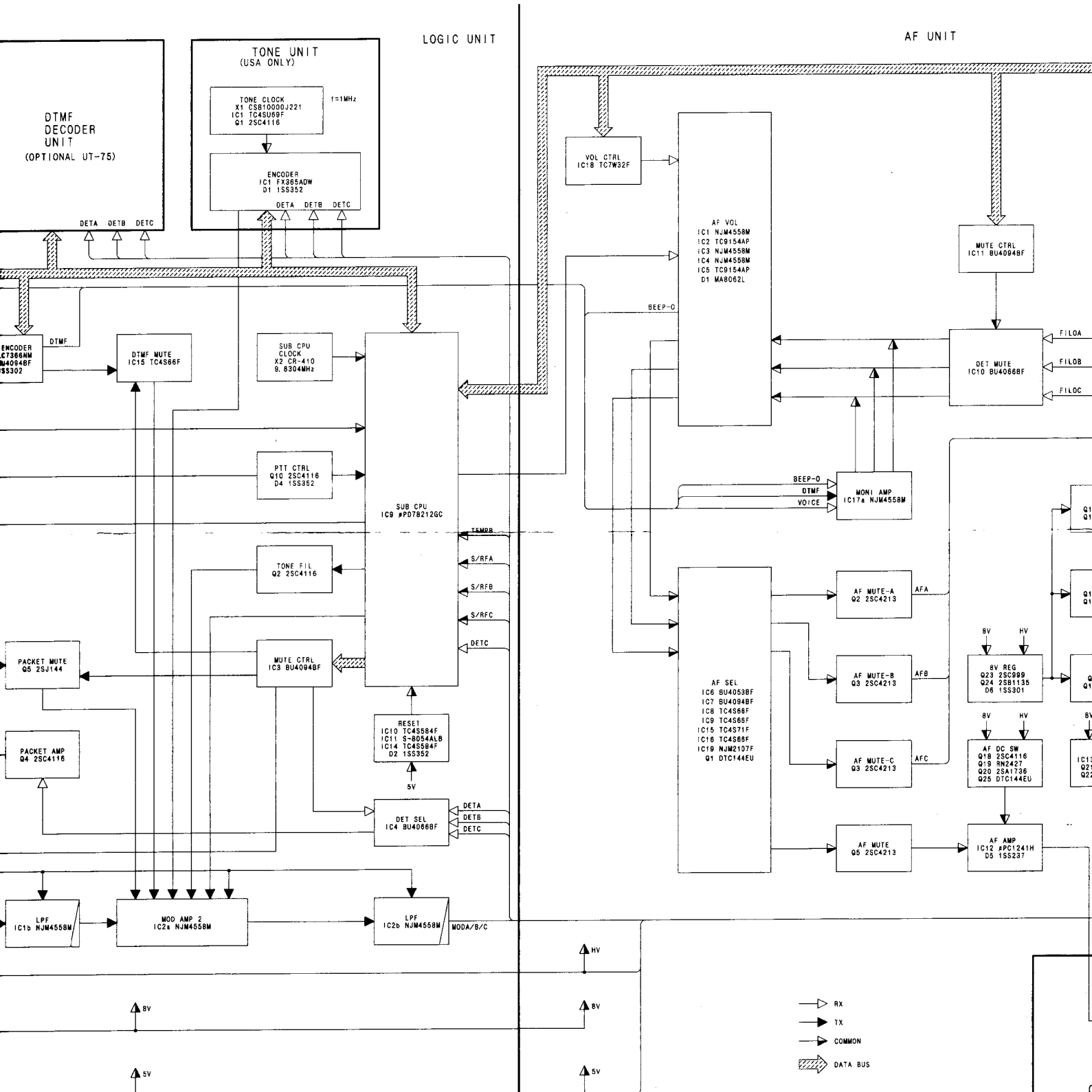

To upgrade quality, some components may be subject to change without notice.



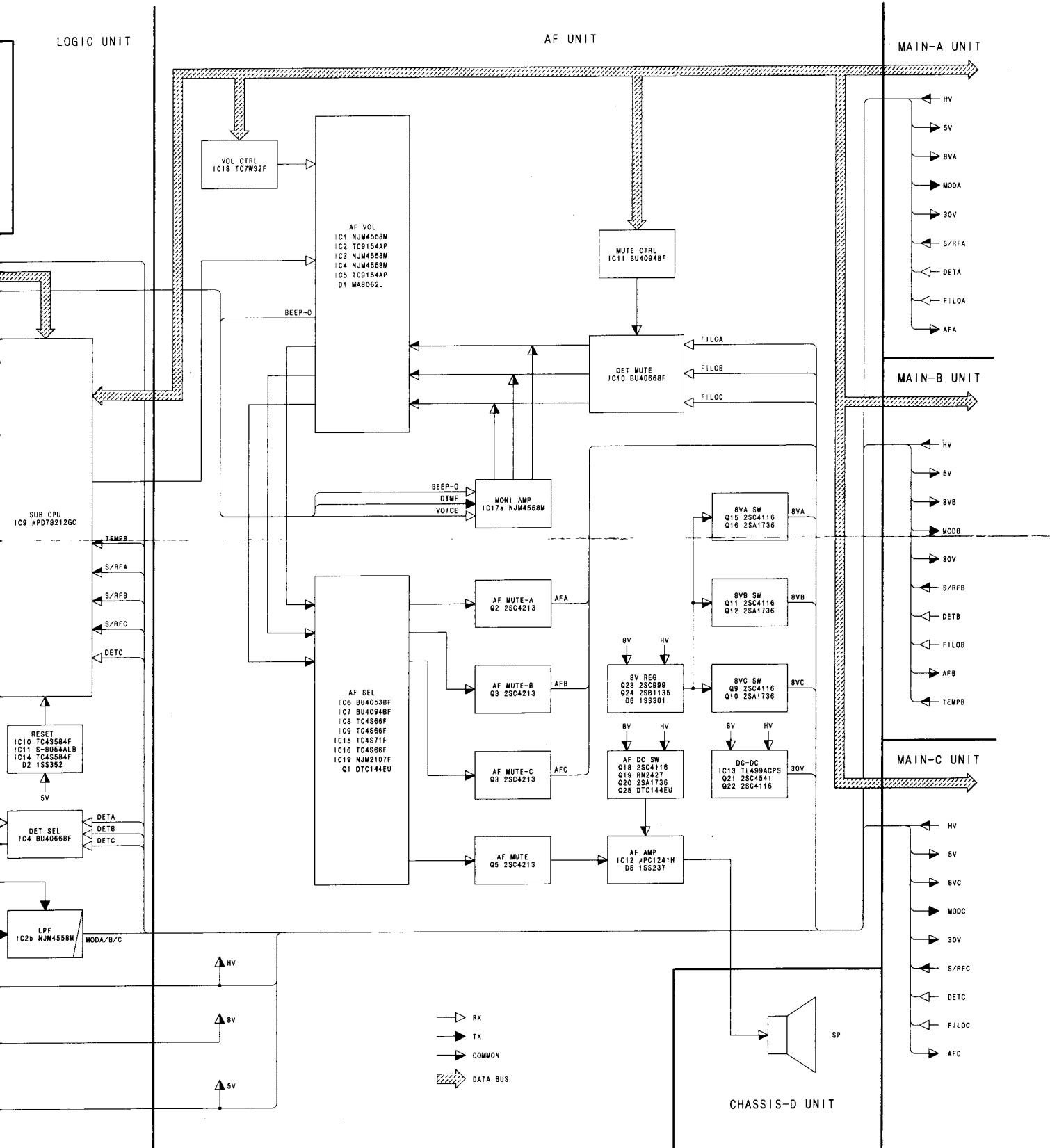

To upgrade quality, some components may be subject to change without notice.

A-5253S-4EX  
 Printed in Japan  
 Copyright © 1993 by Icom Inc.

Icom Inc.

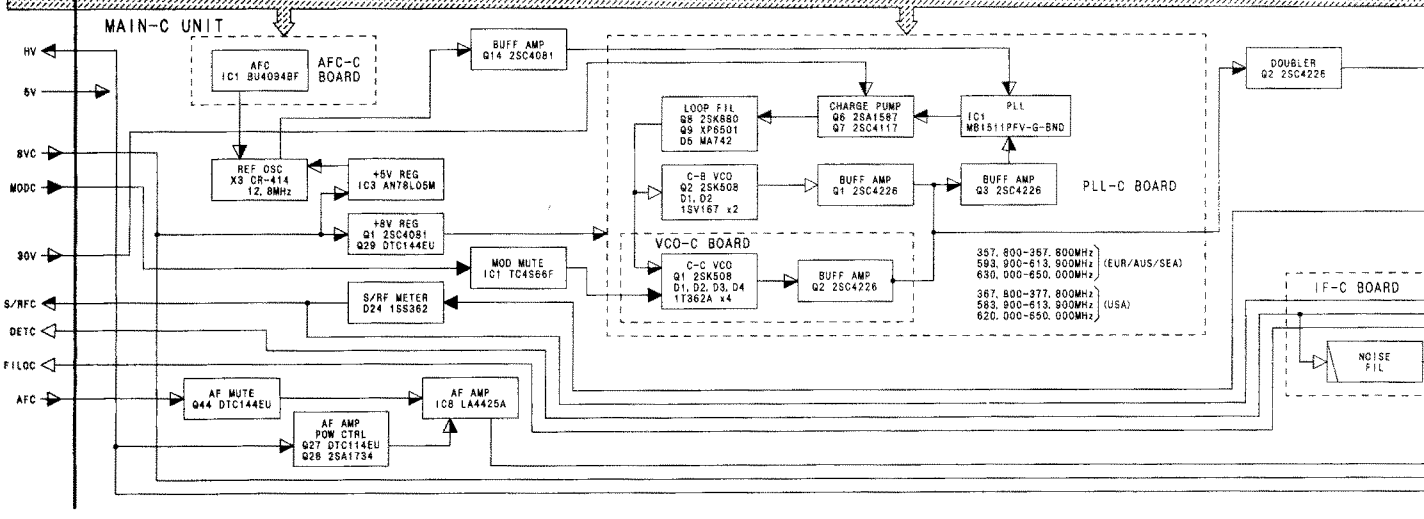
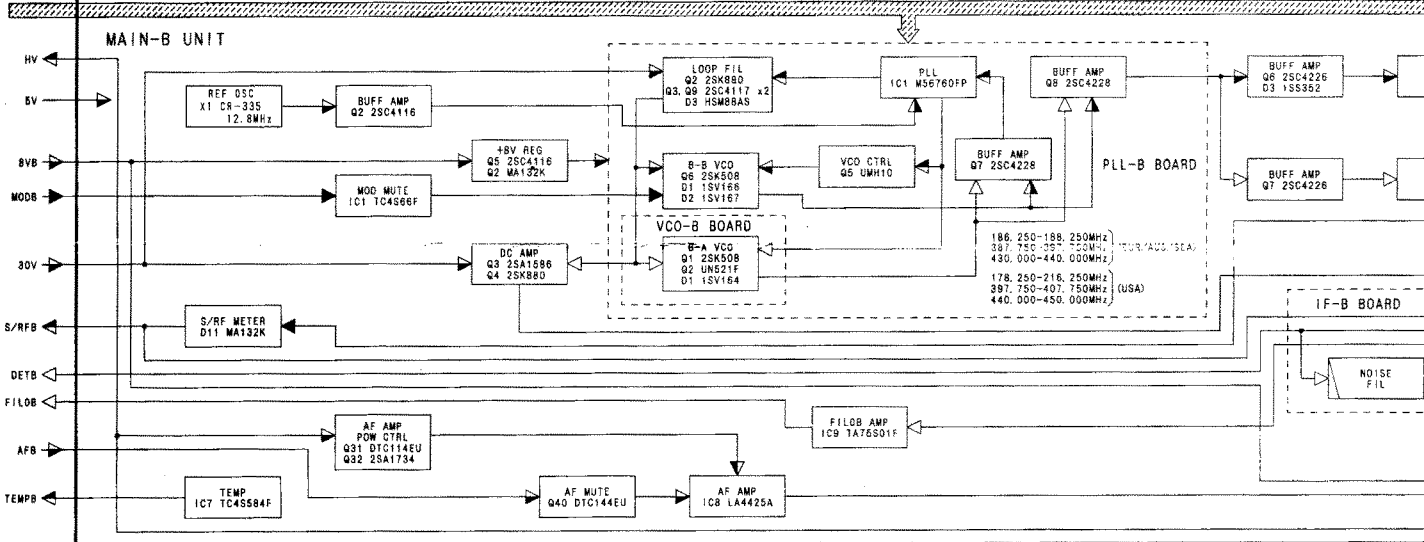
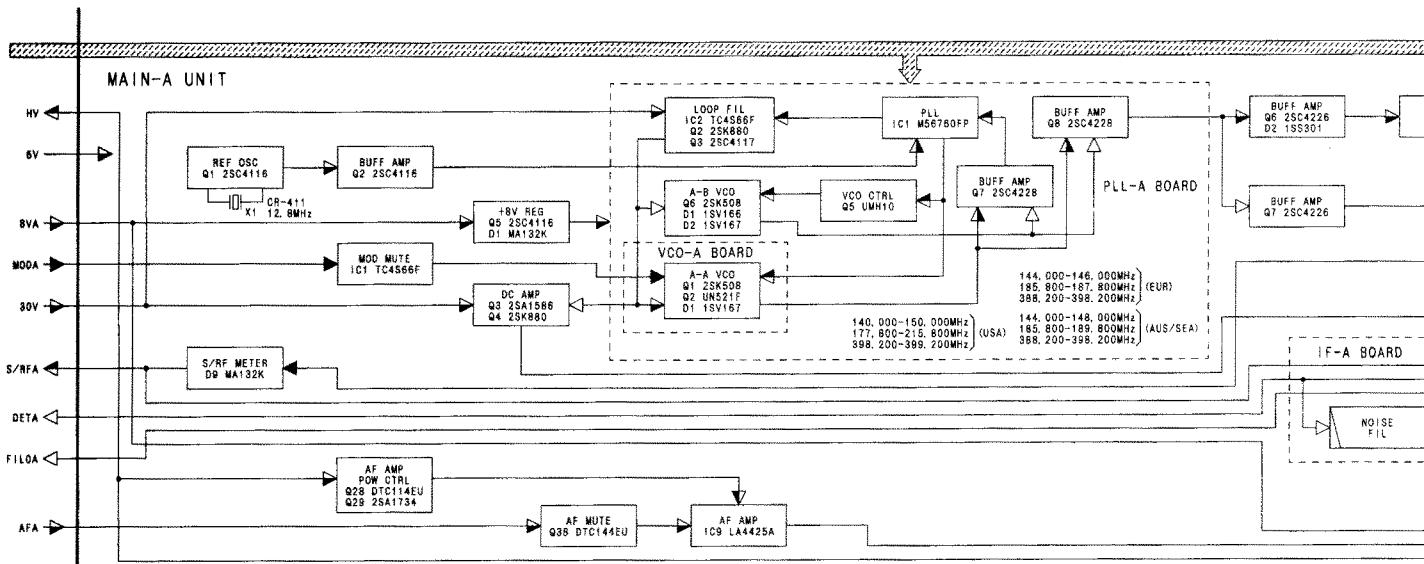

TO AF UNIT

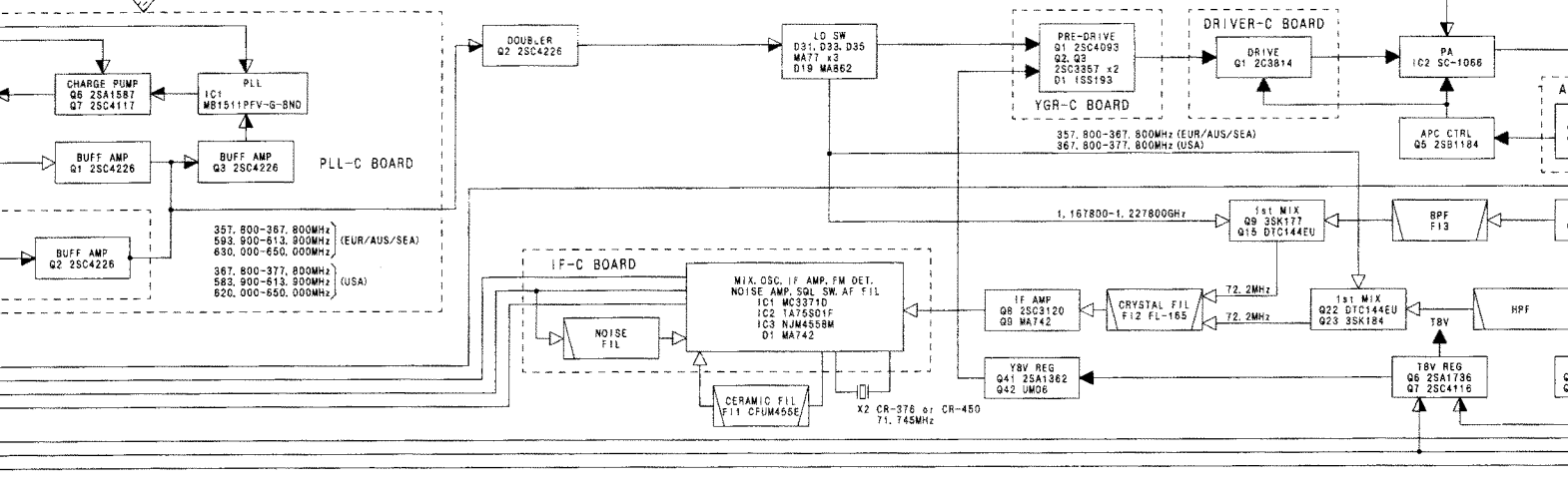
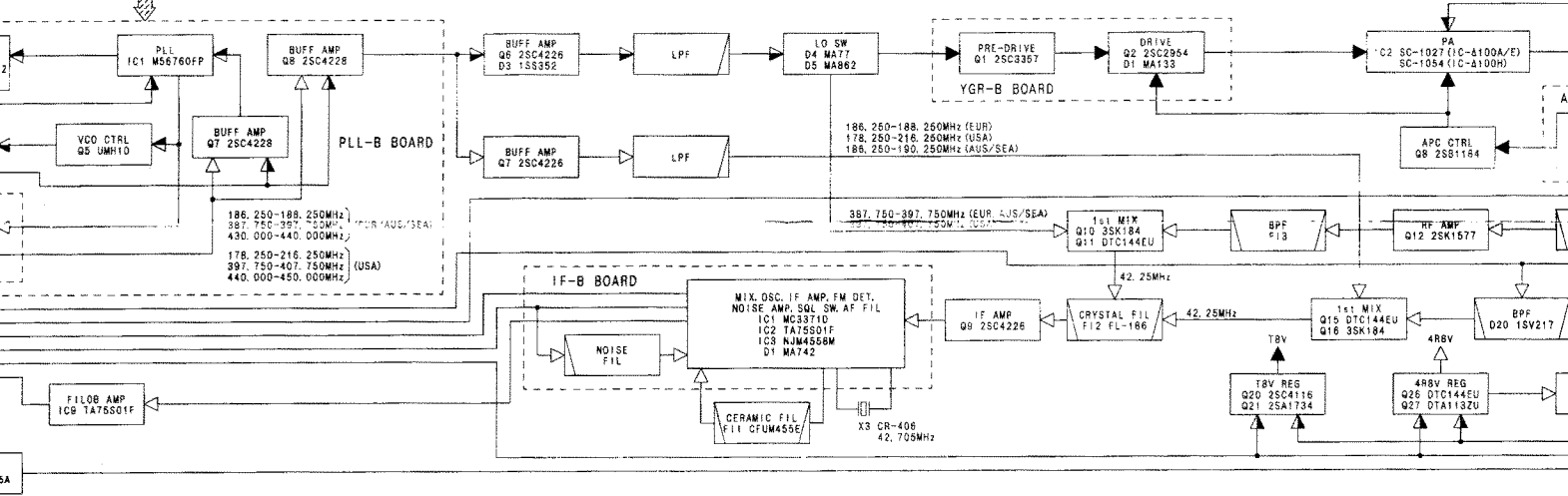
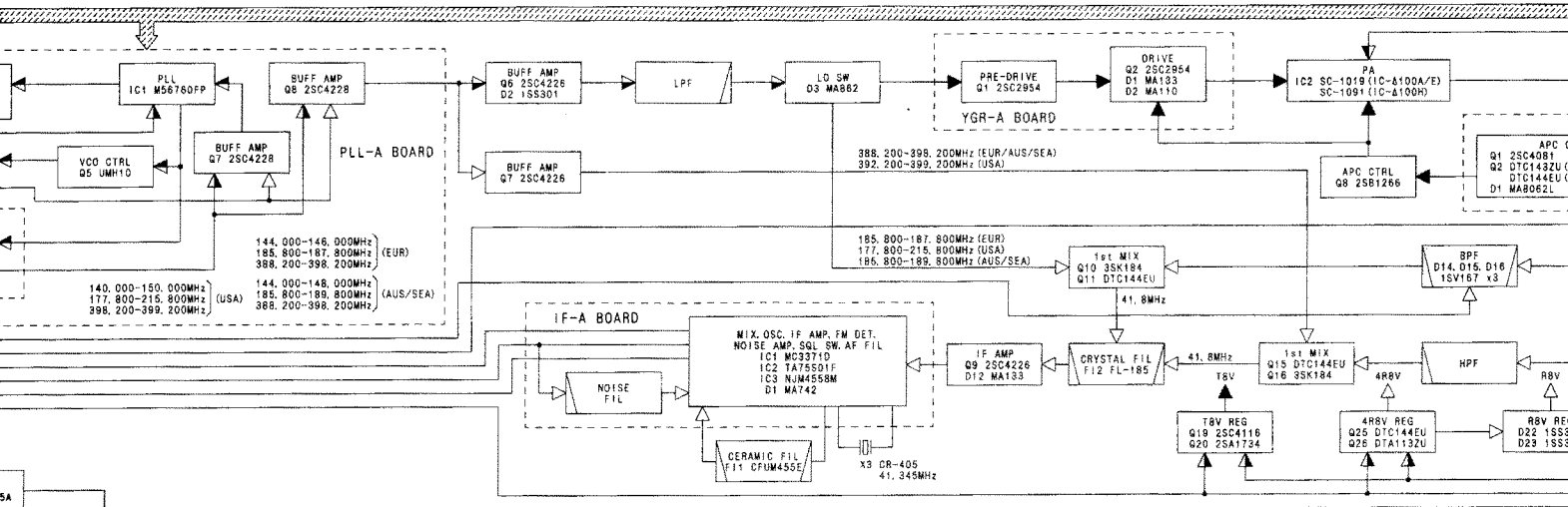

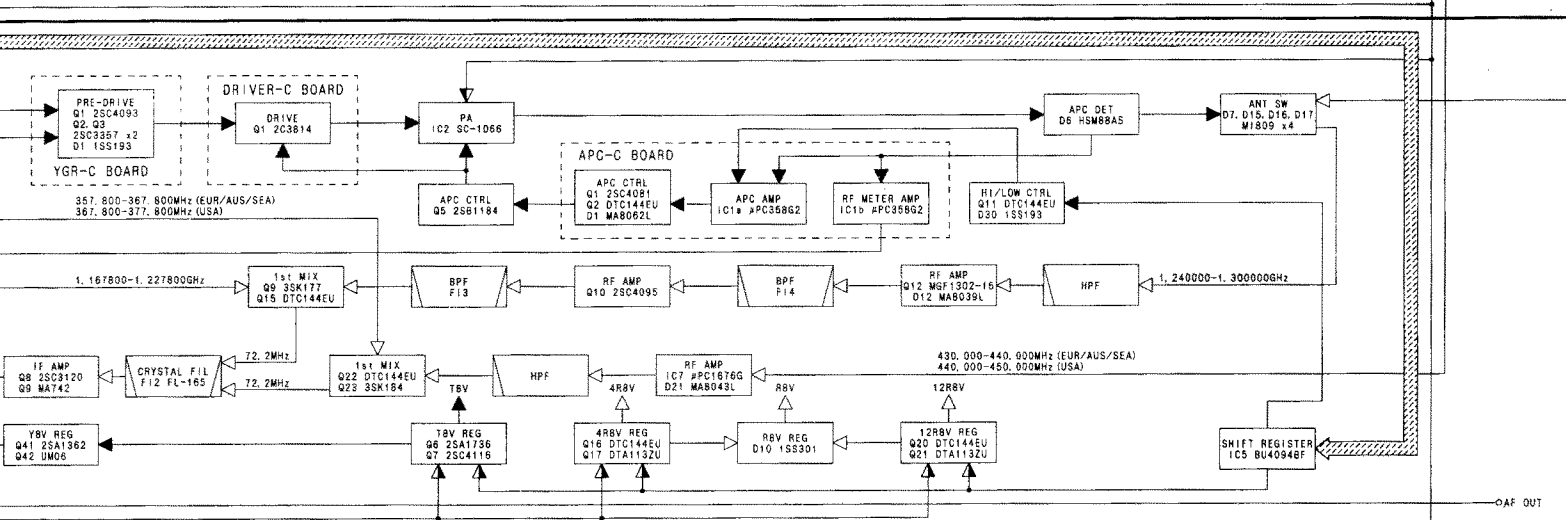
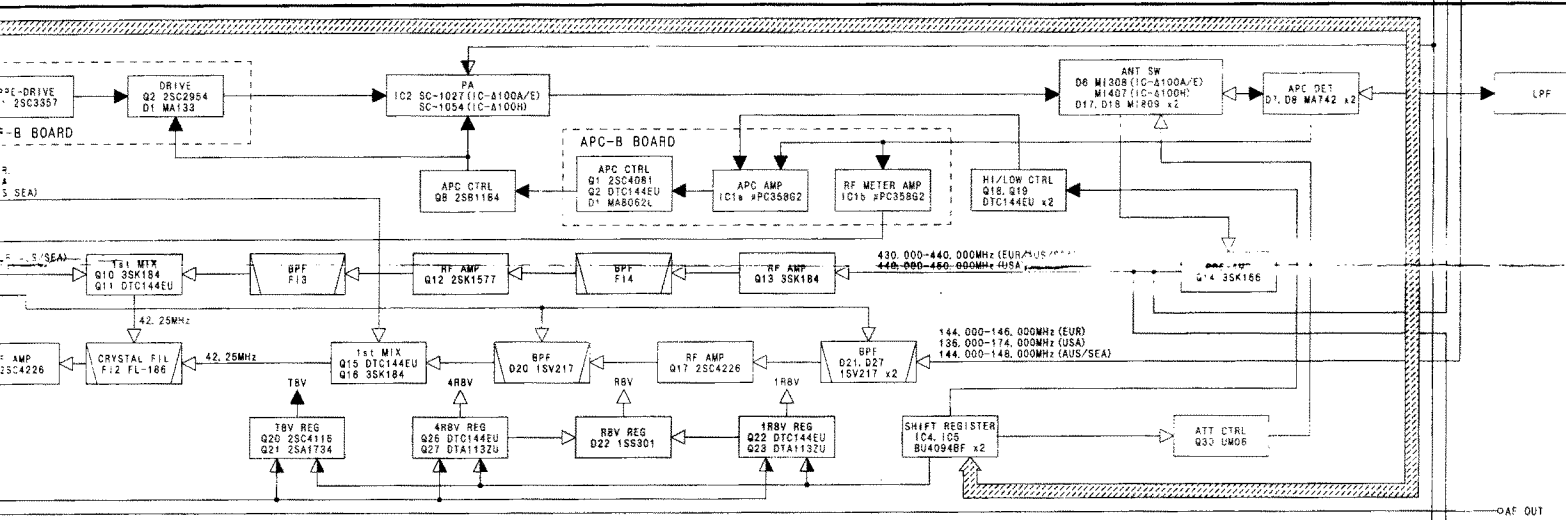
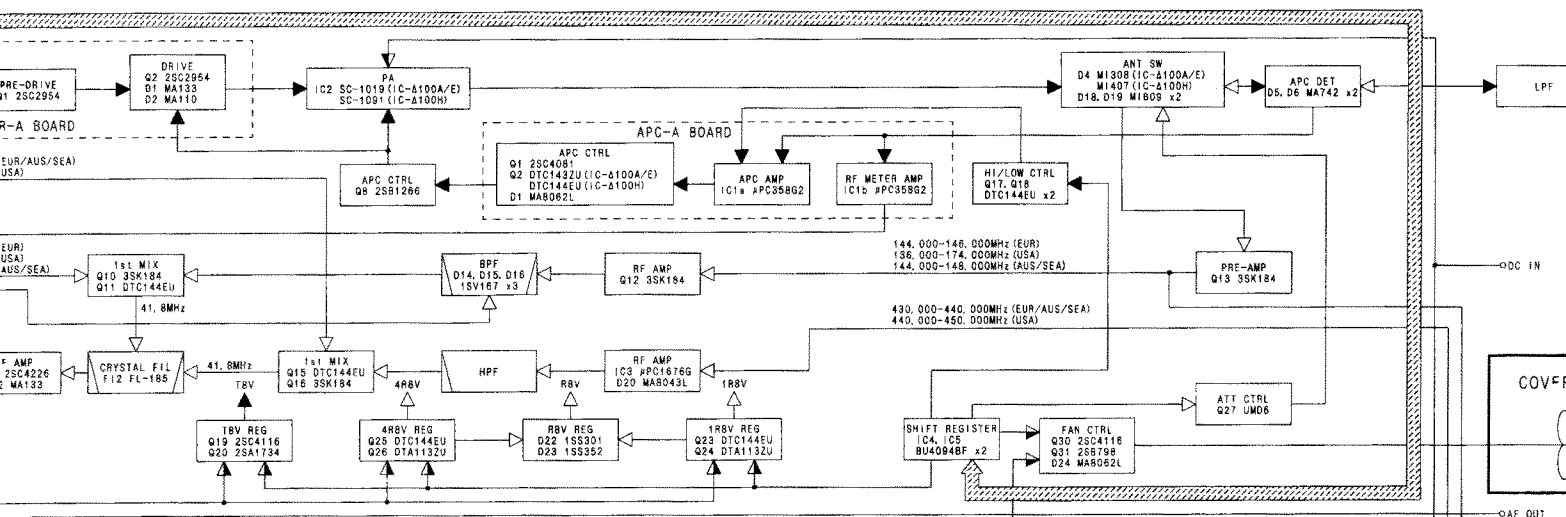

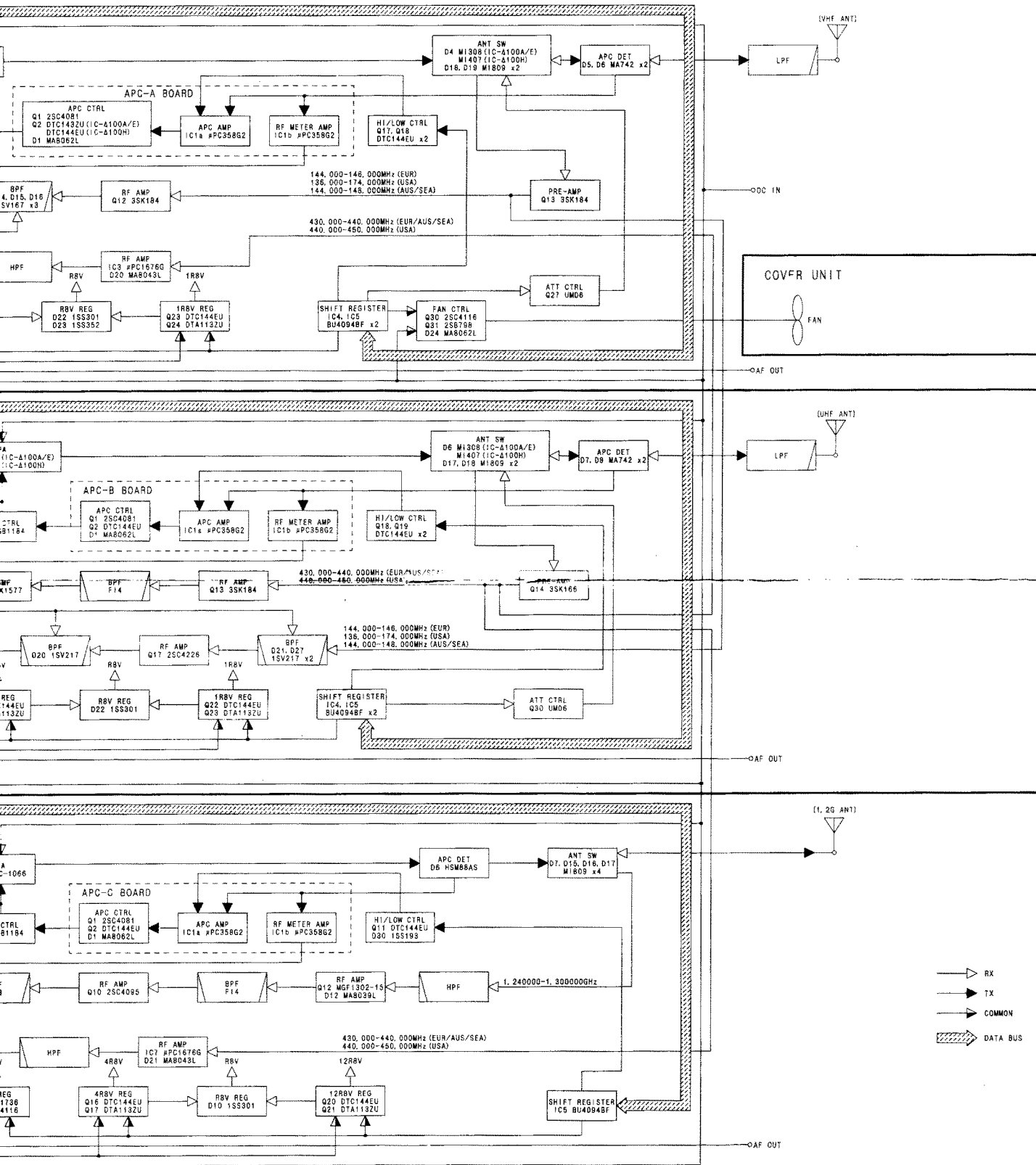

- RX
- TX
- COMMON
- ▨ DATA BUS

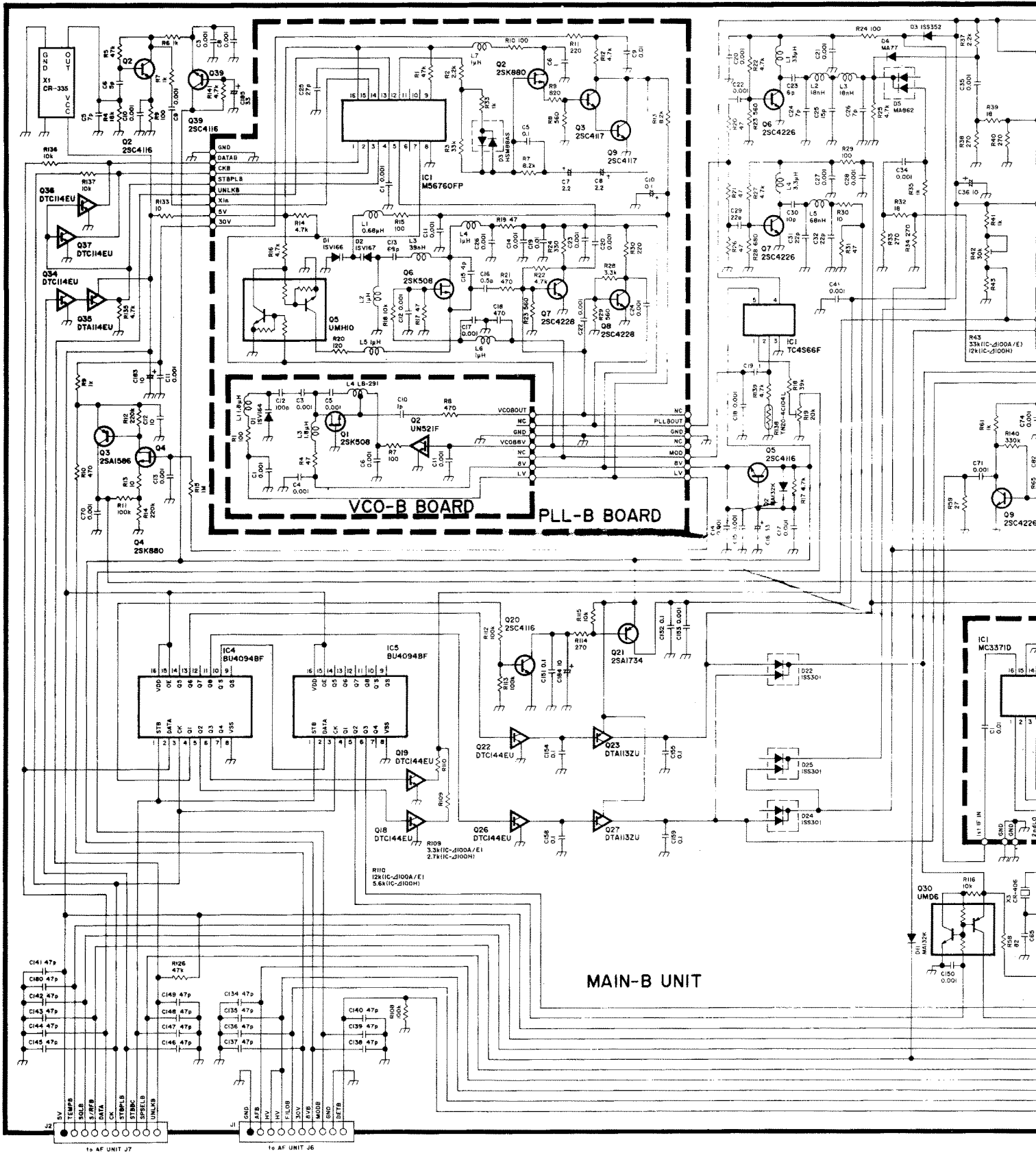

# SCHEMATIC DIAGRAM

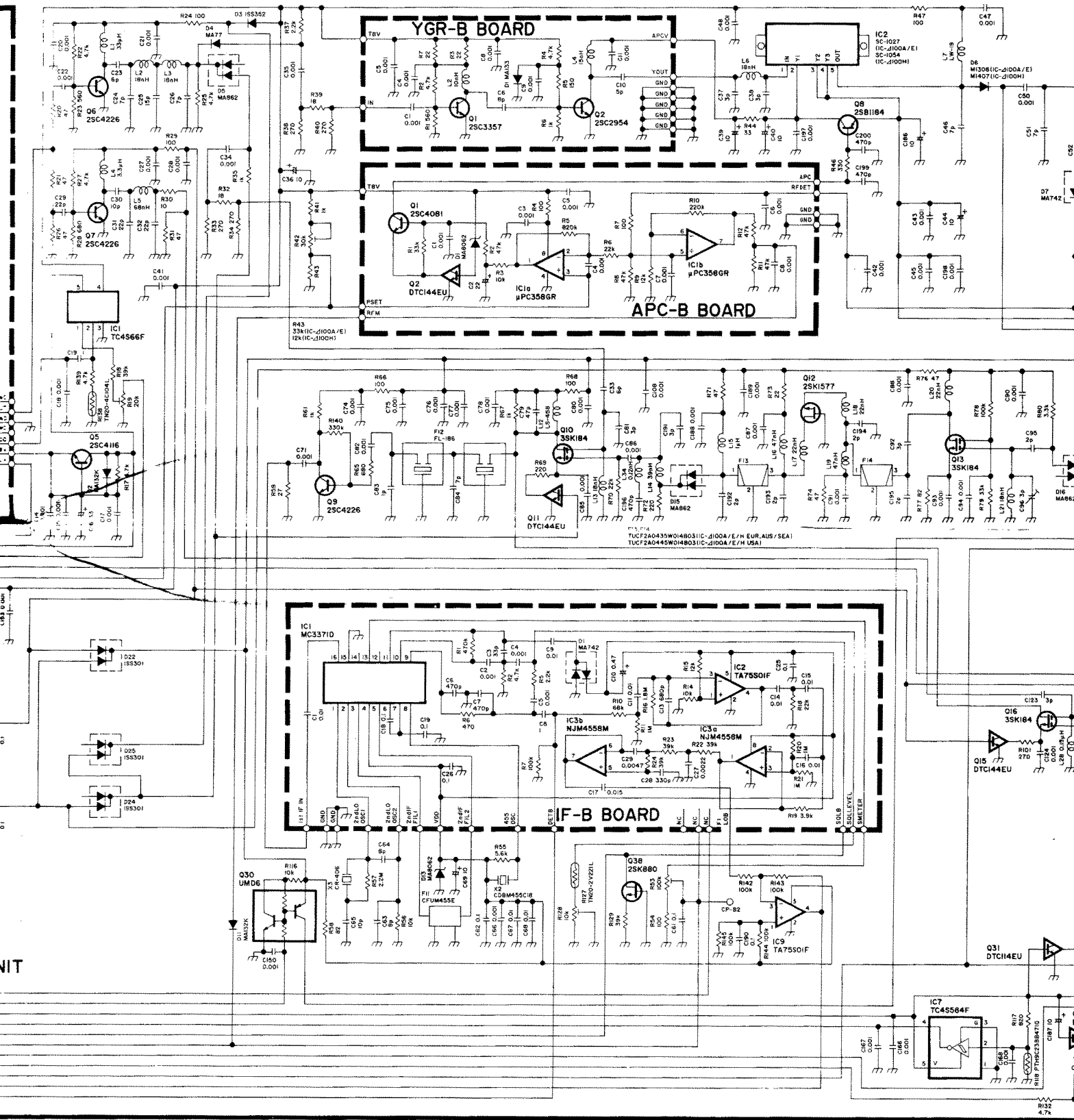

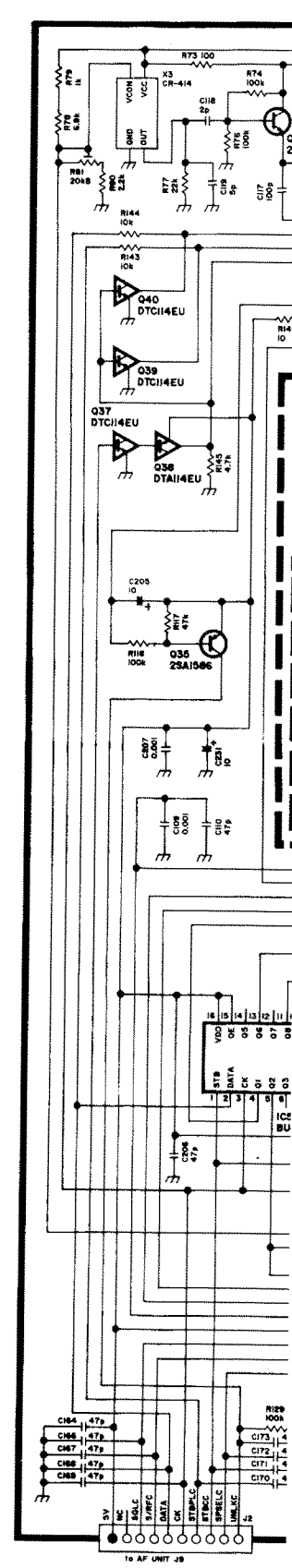
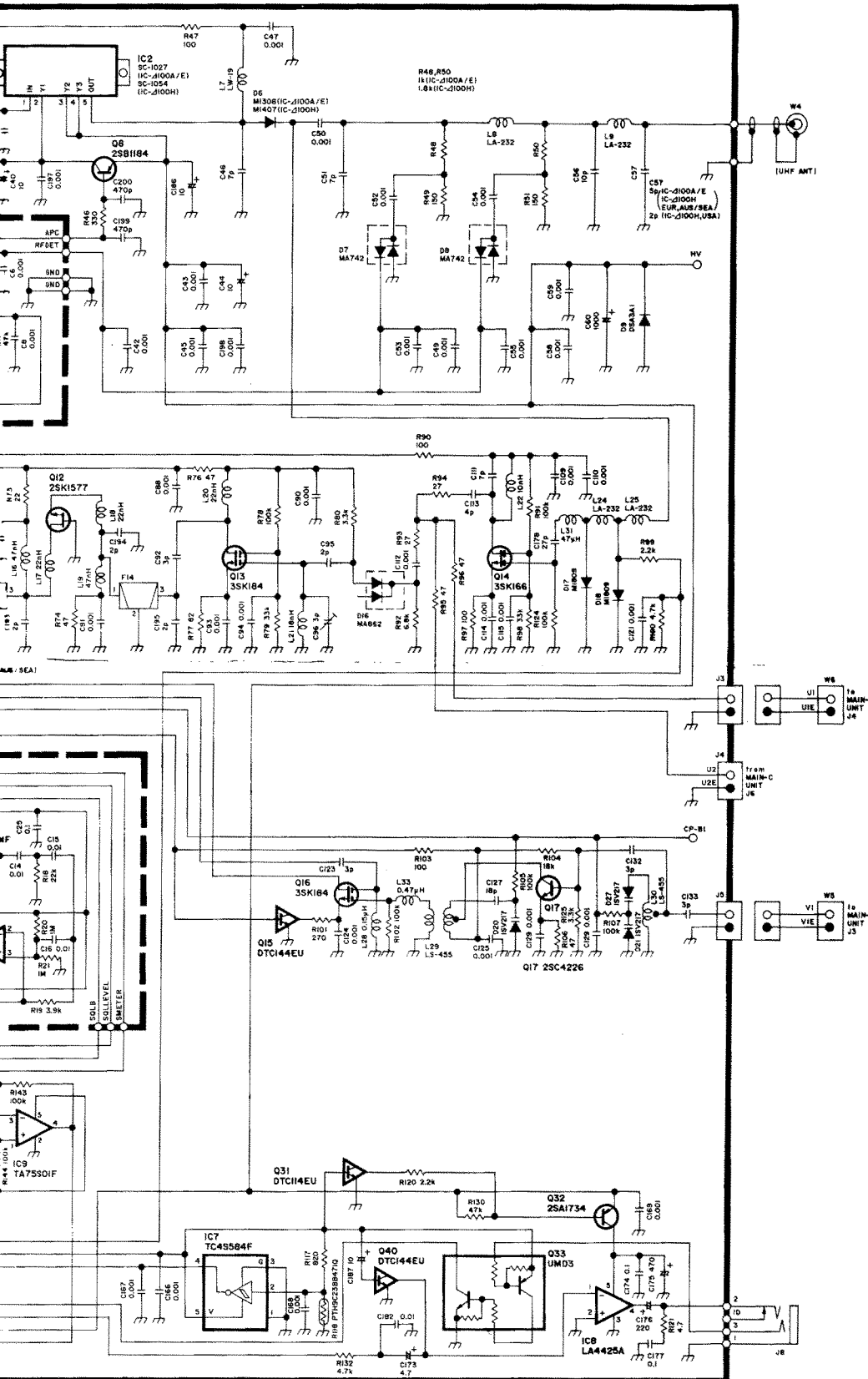



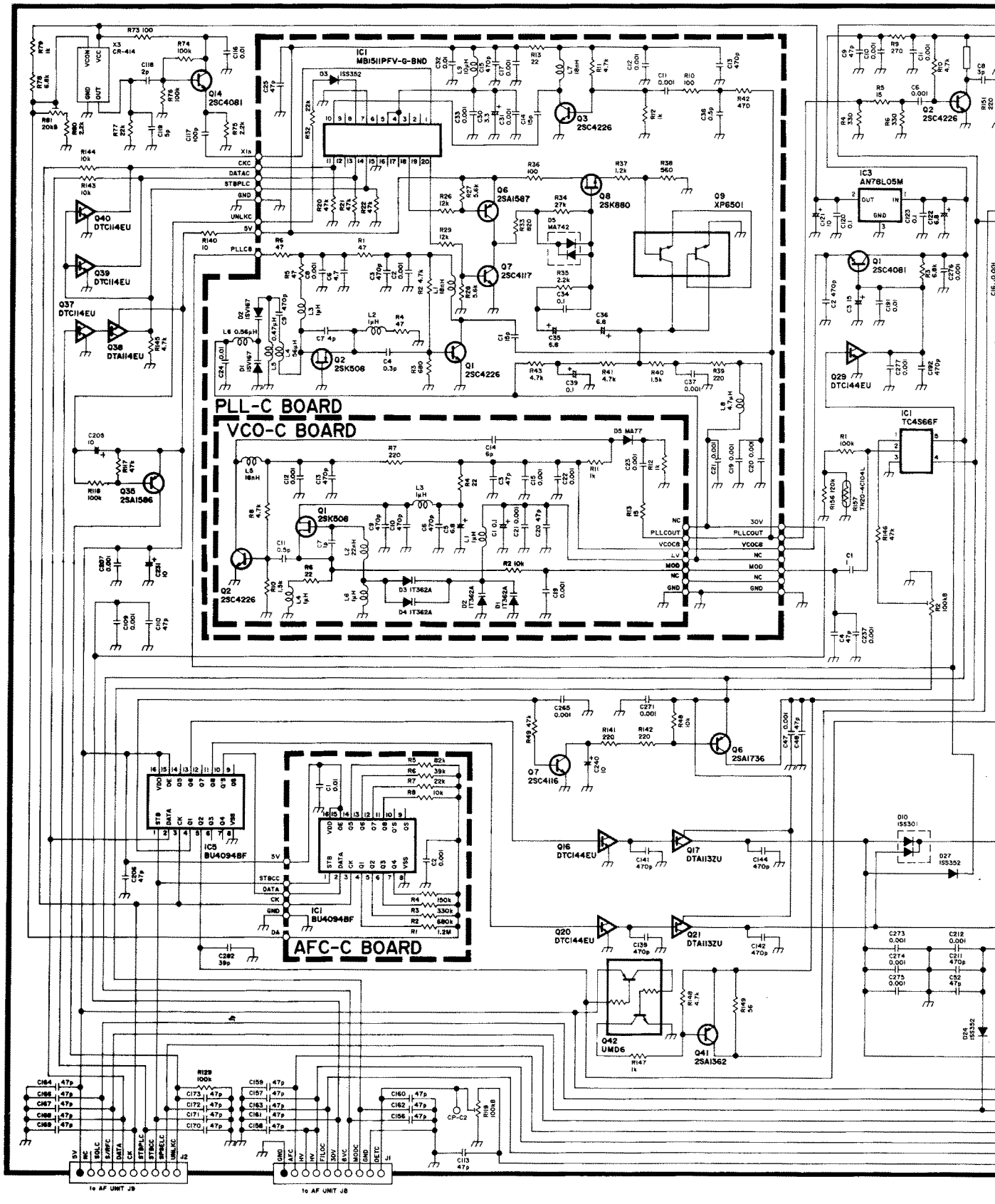

to AF UNIT 1B

to AF UNIT 1B

D54 1S5352

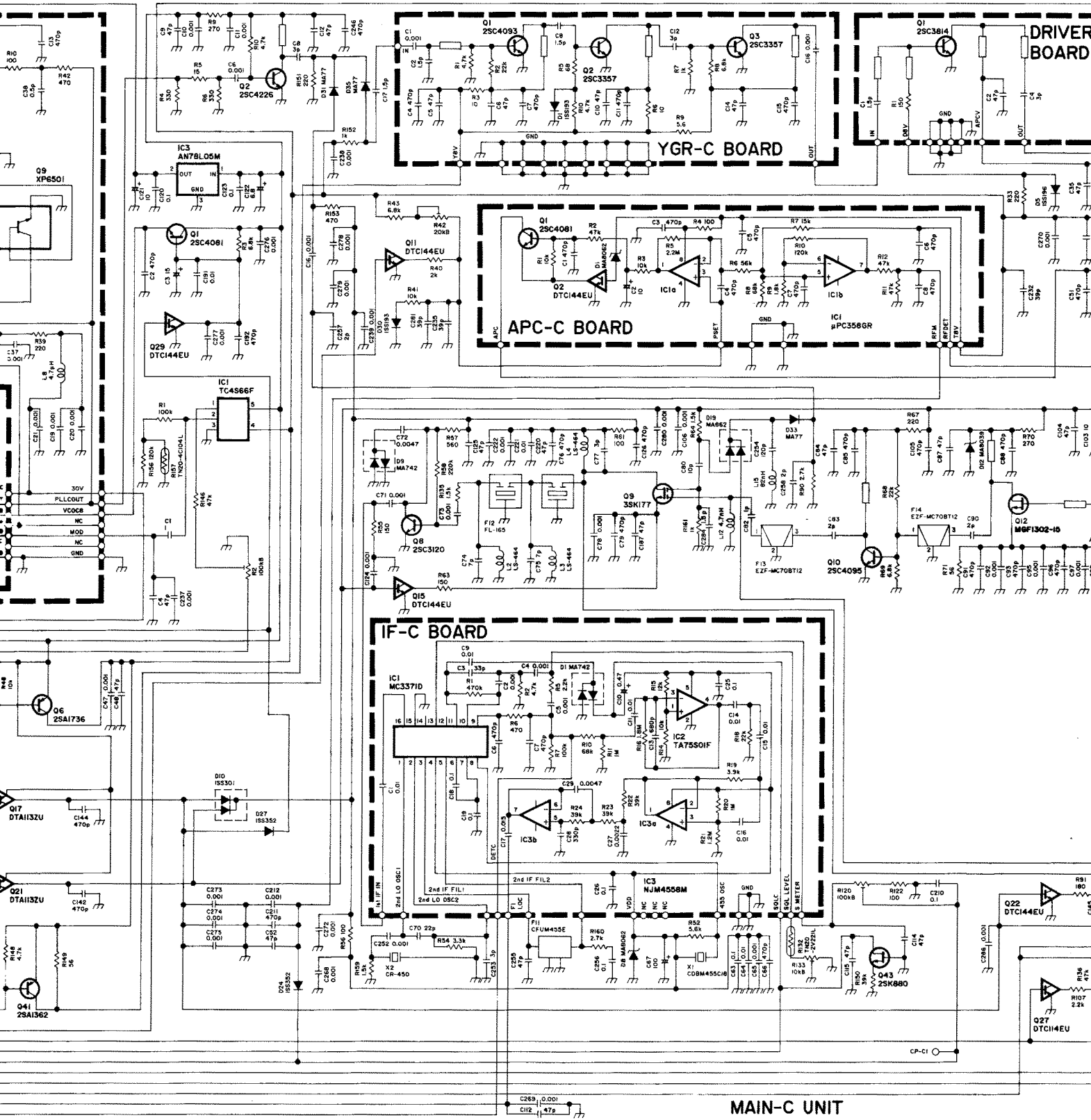

**MAIN-C UNIT**

To upgrade quality, some components may be subject to change without notice.

A-  
Pr  
Co

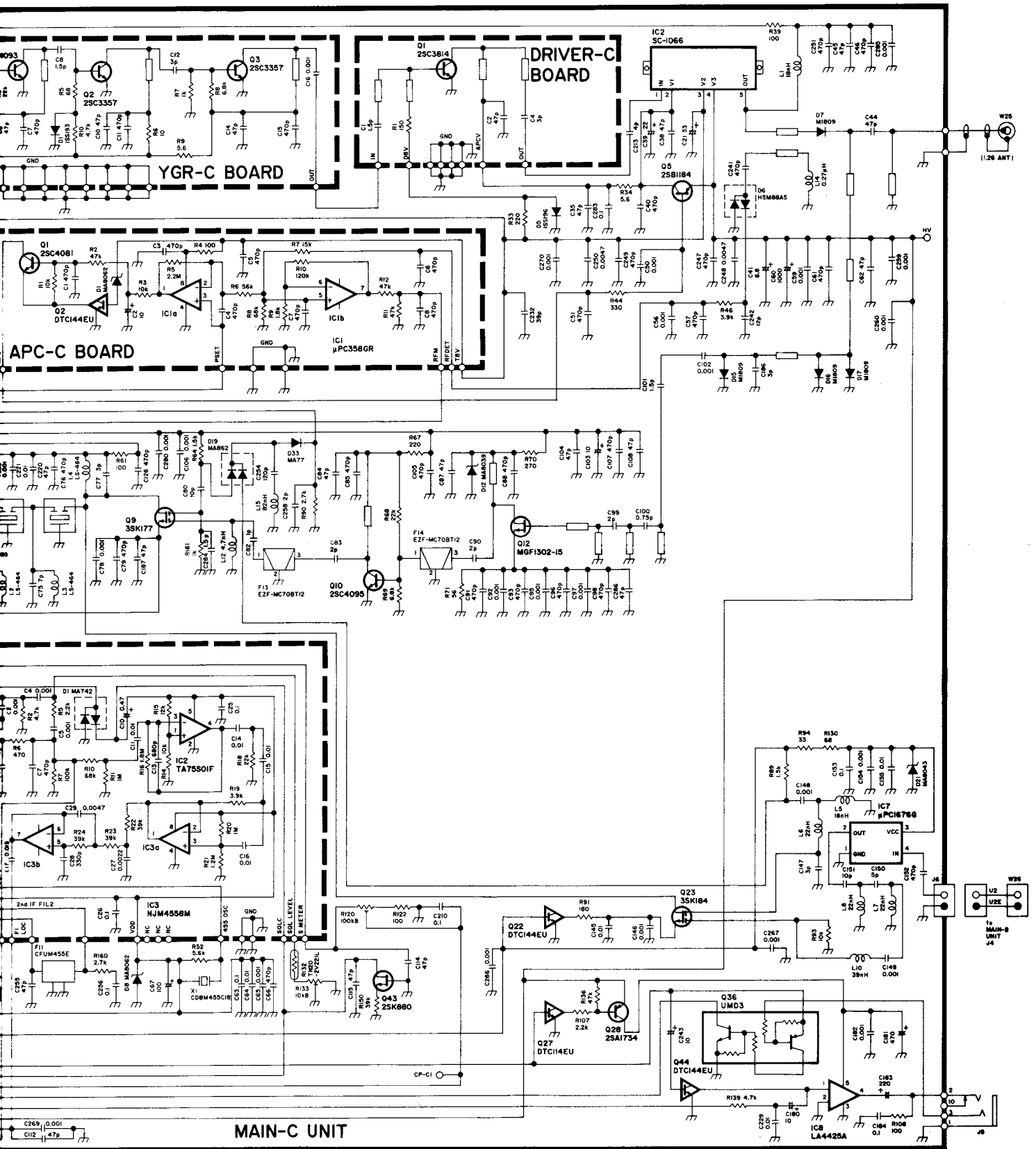

To upgrade quality, some components may be subject to change without notice.

A-5253S-3EX  
 Printed in Japan  
 Copyright © 1993 by Icom Inc.

Icom Inc.

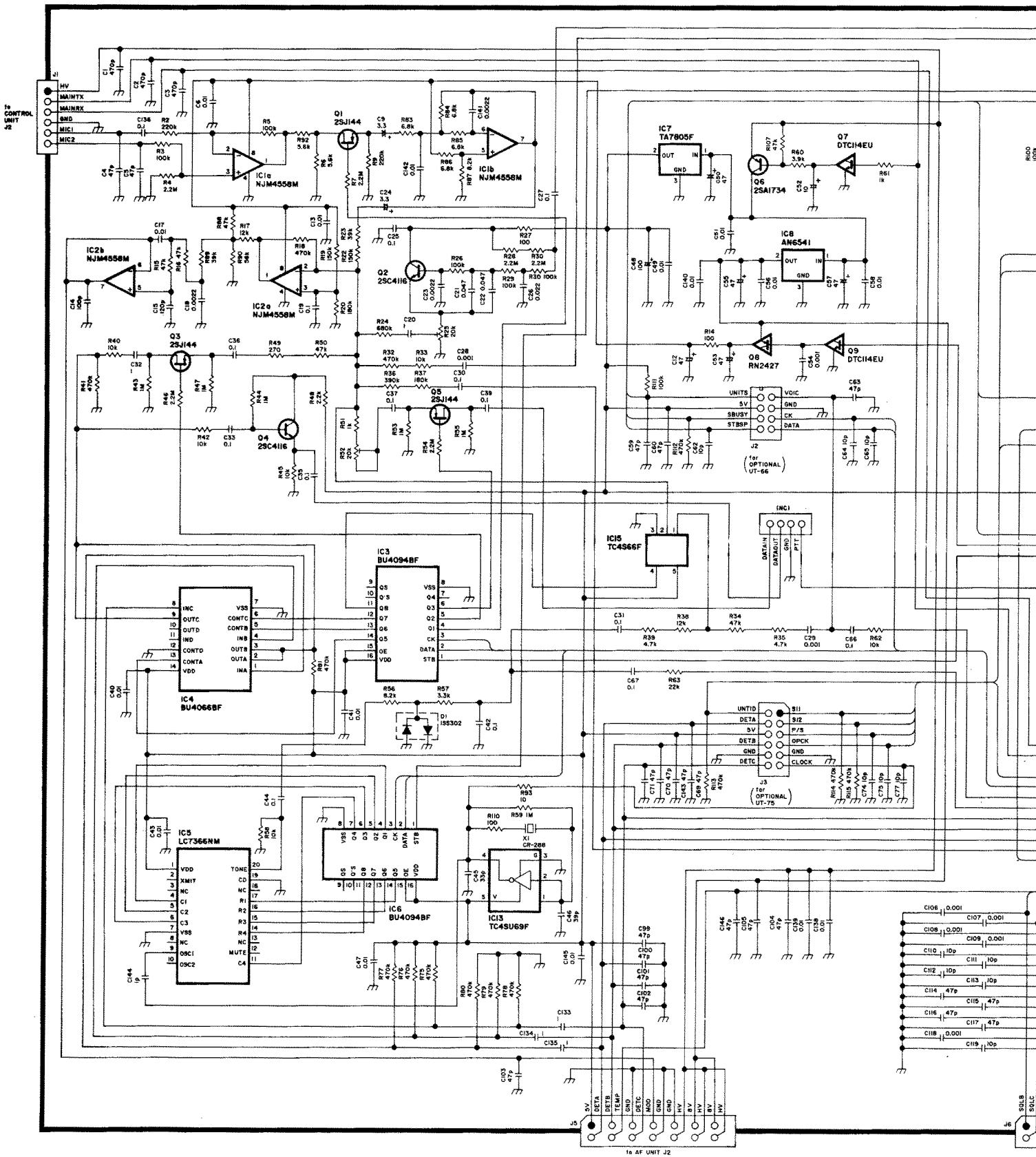

5V CONTROL UNIT J2

5V CONTROL UNIT J2

5V CONTROL UNIT J2

5V CONTROL UNIT J2

5V CONTROL UNIT J2

5V CONTROL UNIT J2

5V CONTROL UNIT J2

5V CONTROL UNIT J2

5V CONTROL UNIT J2

5V CONTROL UNIT J2

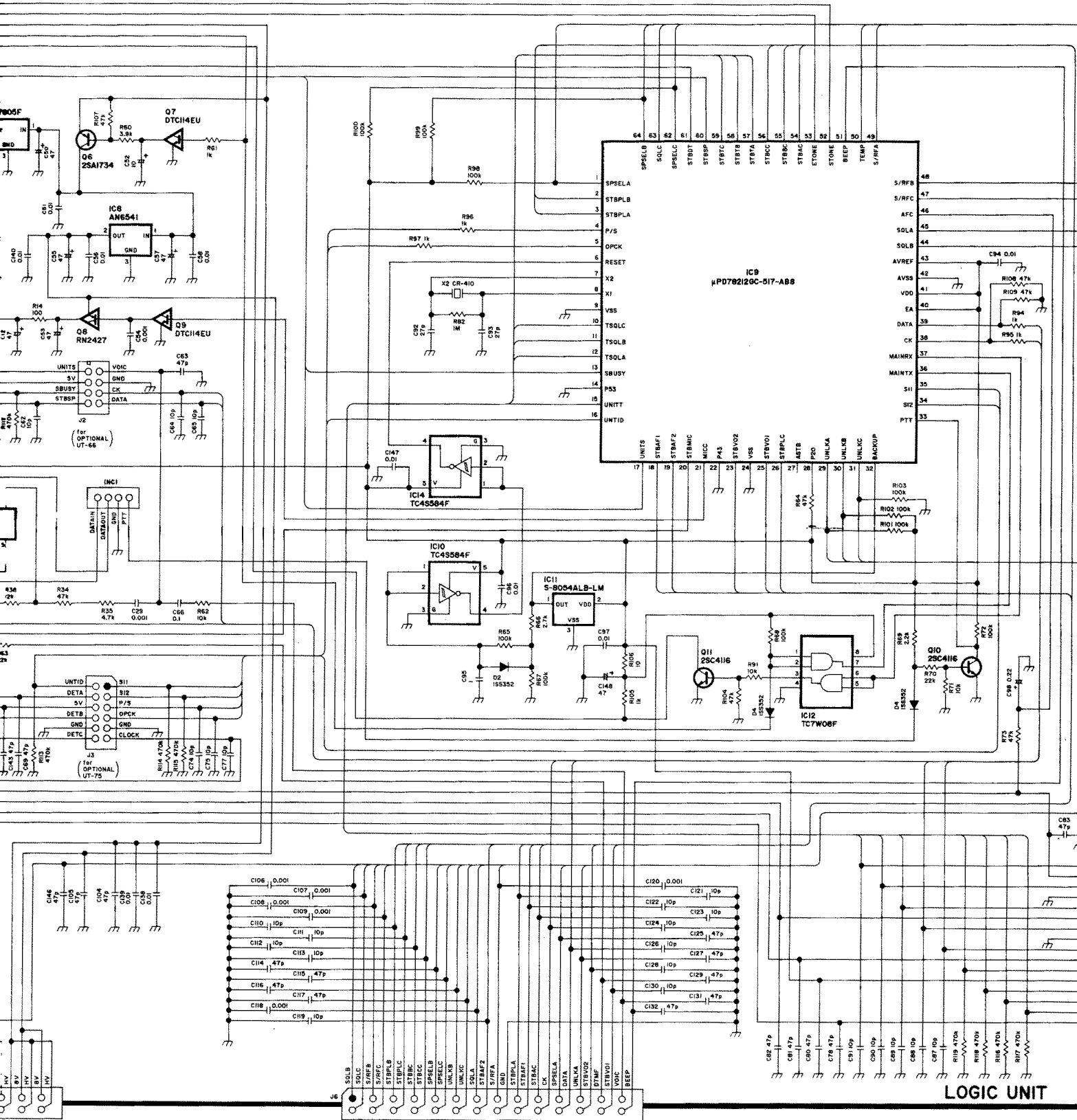

**LOGIC UNIT**

16 AF UNIT J3

- |      |       |      |       |      |       |      |     |
|------|-------|------|-------|------|-------|------|-----|
| C106 | 0.001 | C107 | 0.001 | C120 | 0.001 | C121 | 10p |
| C108 | 0.001 | C109 | 0.001 | C122 | 10p   | C123 | 10p |
| C110 | 10p   | C111 | 10p   | C124 | 10p   | C125 | 47p |
| C112 | 10p   | C113 | 10p   | C126 | 10p   | C127 | 47p |
| C114 | 47p   | C115 | 47p   | C128 | 10p   | C129 | 47p |
| C116 | 47p   | C117 | 47p   | C130 | 10p   | C131 | 47p |
| C118 | 0.001 | C119 | 10p   | C132 | 47p   |      |     |

- |     |     |      |      |
|-----|-----|------|------|
| C82 | 47p | C83  | 47p  |
| C81 | 47p | C80  | 47p  |
| C78 | 47p | C79  | 10p  |
| C76 | 47p | C77  | 10p  |
| C75 | 10p | R115 | 470k |
| C69 | 10p | R116 | 470k |
| C68 | 10p | R118 | 470k |
| C67 | 10p | R117 | 470k |

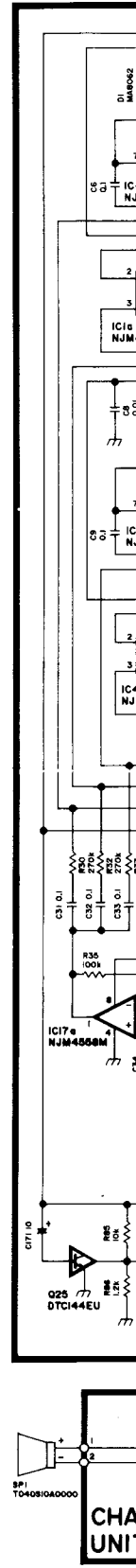
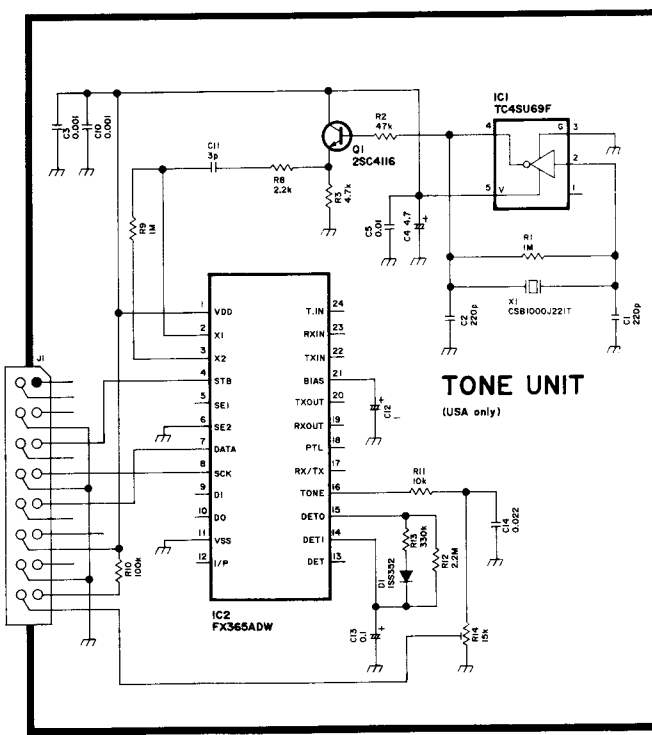
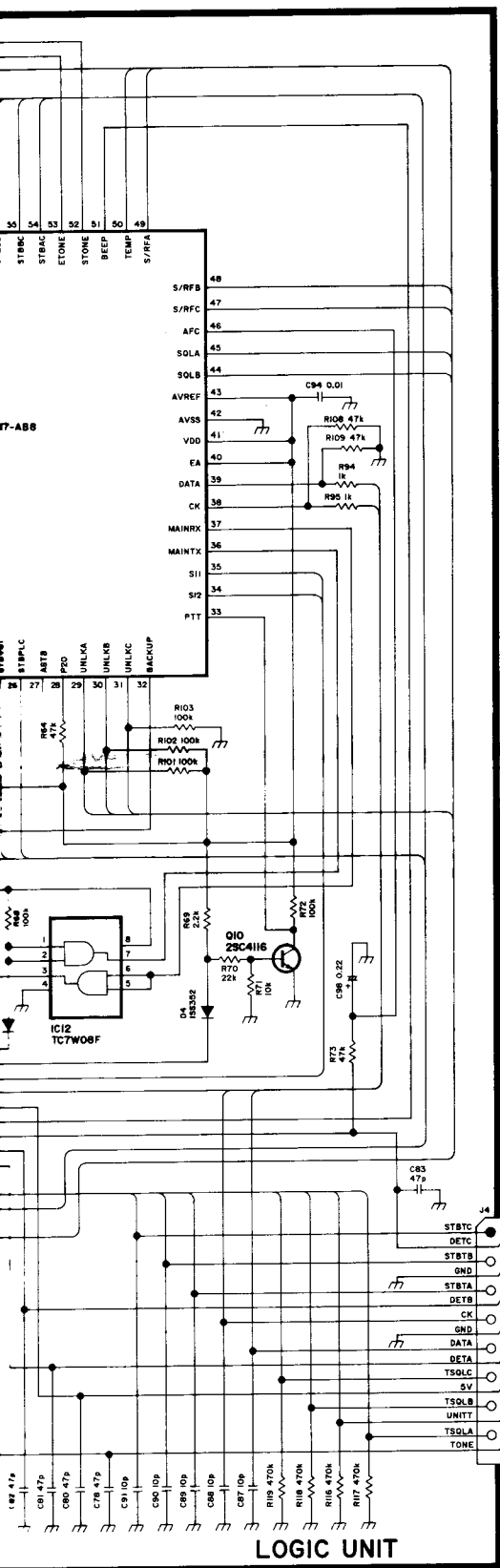

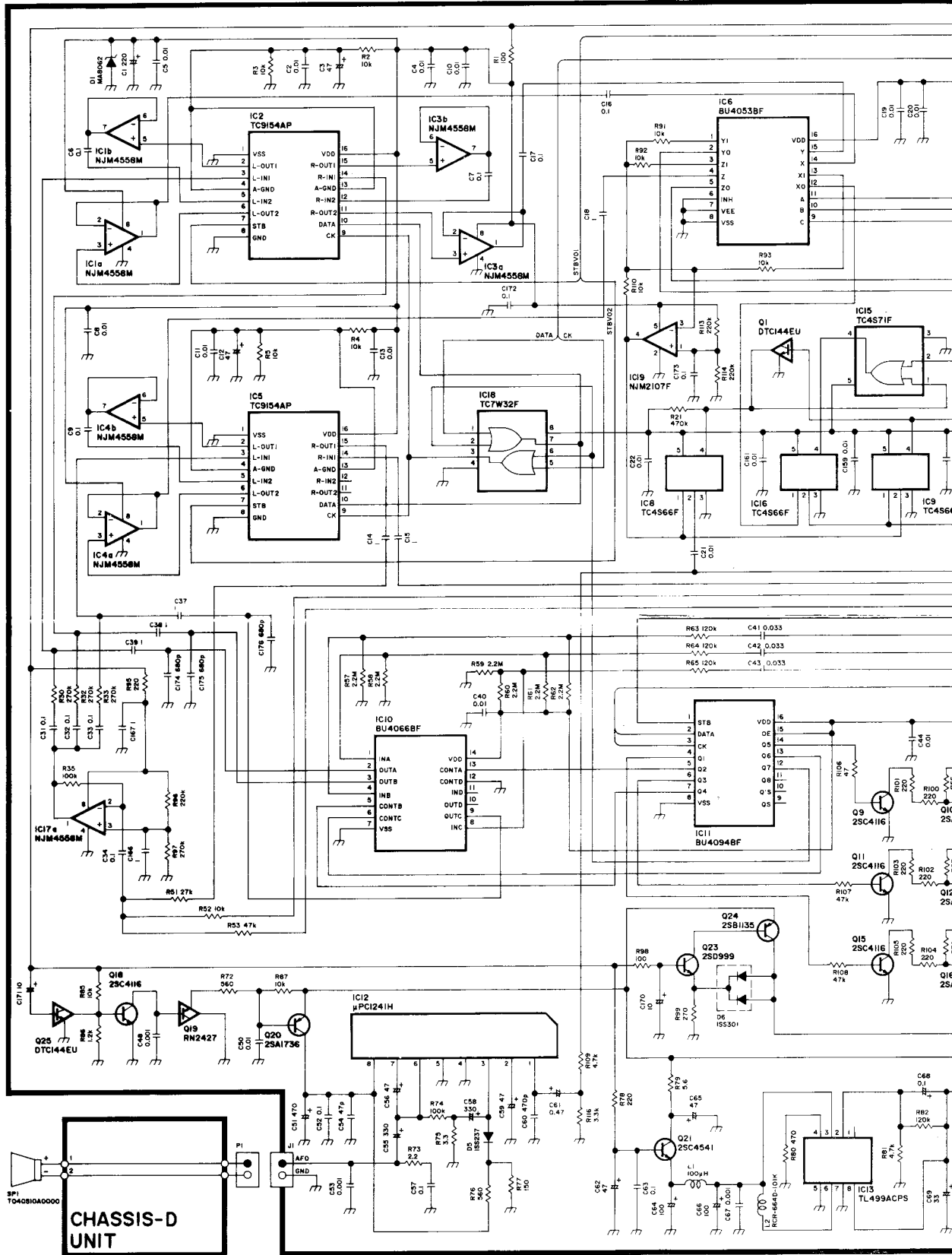

**CHASSIS-D  
UNIT**





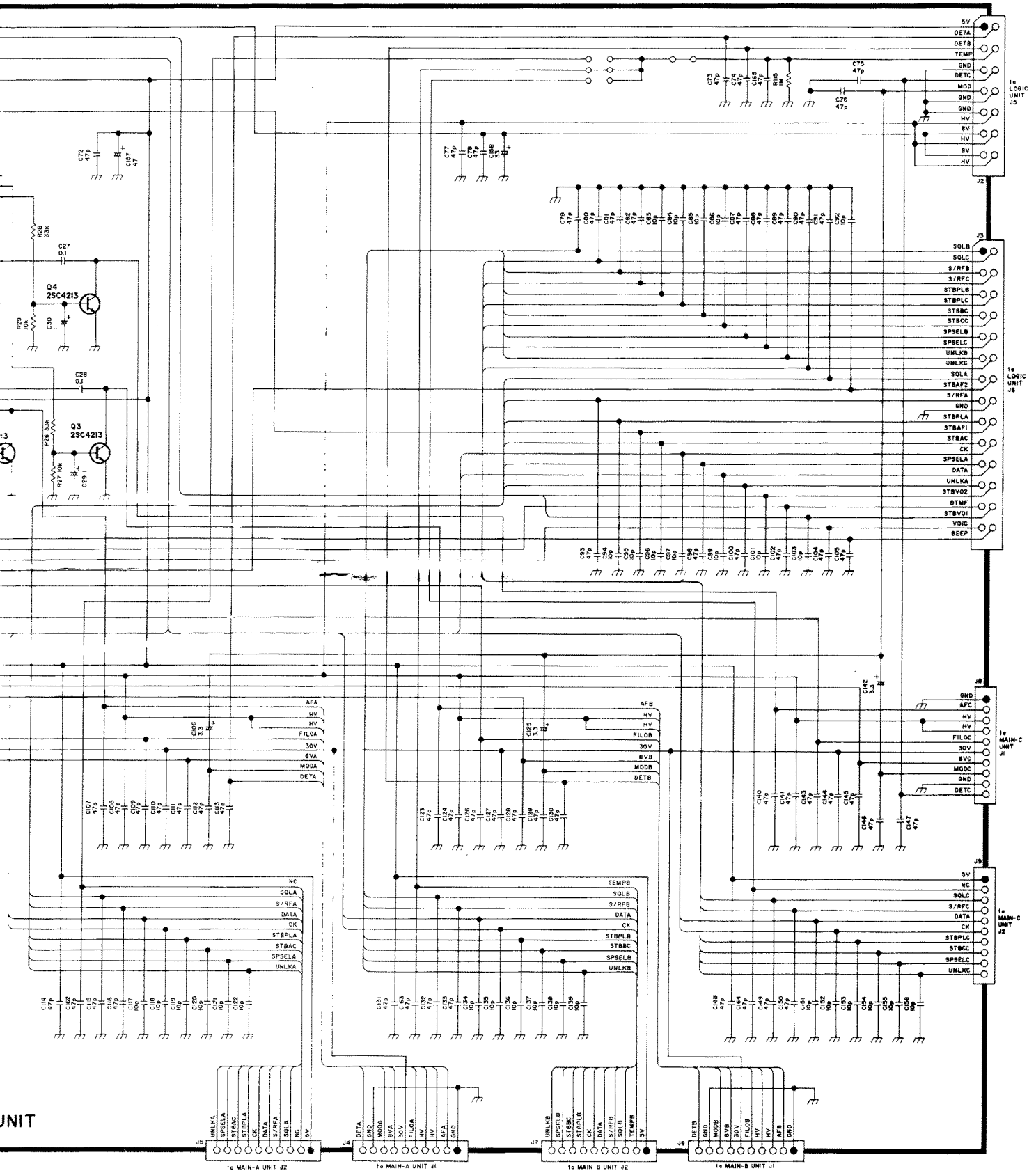

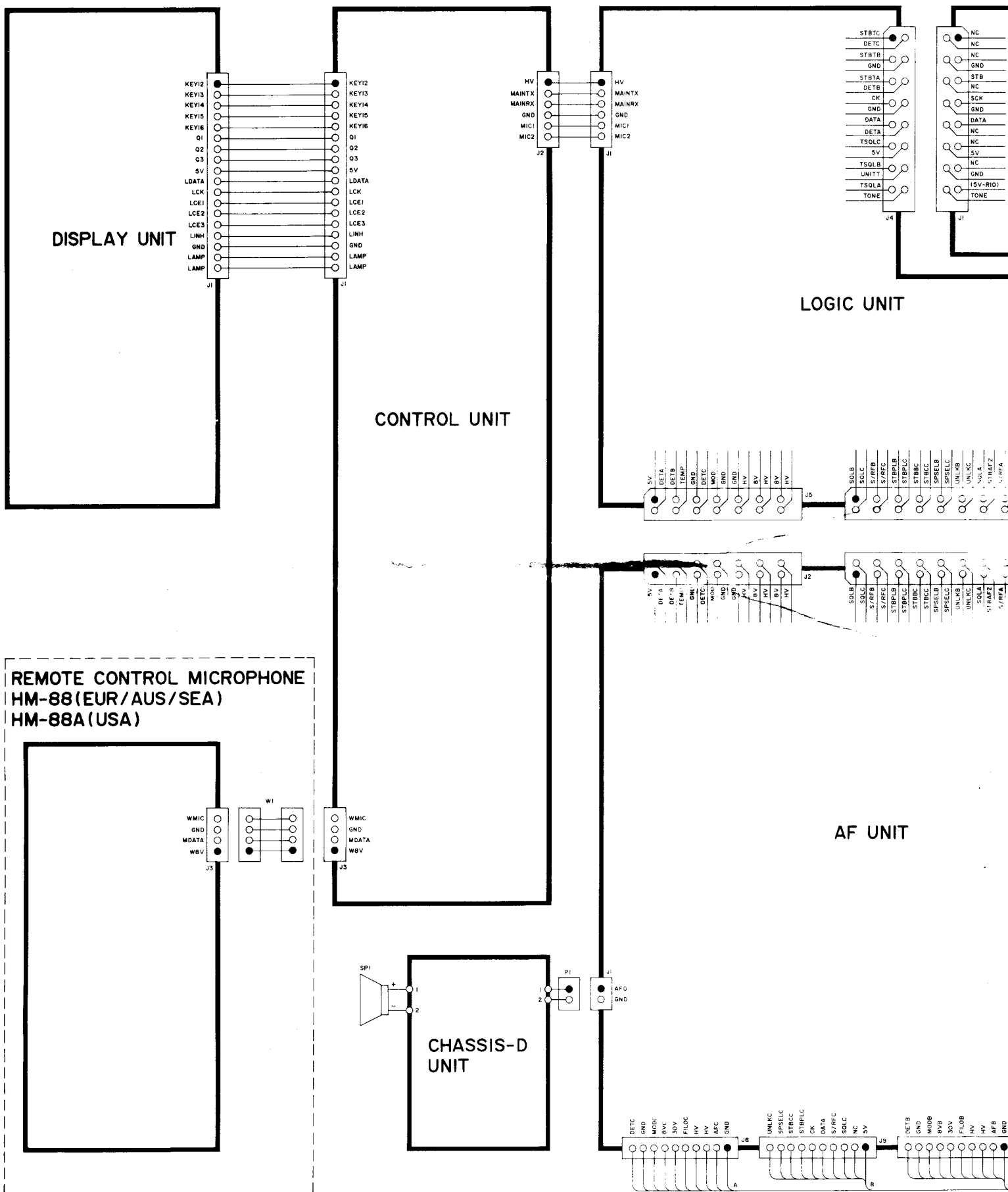



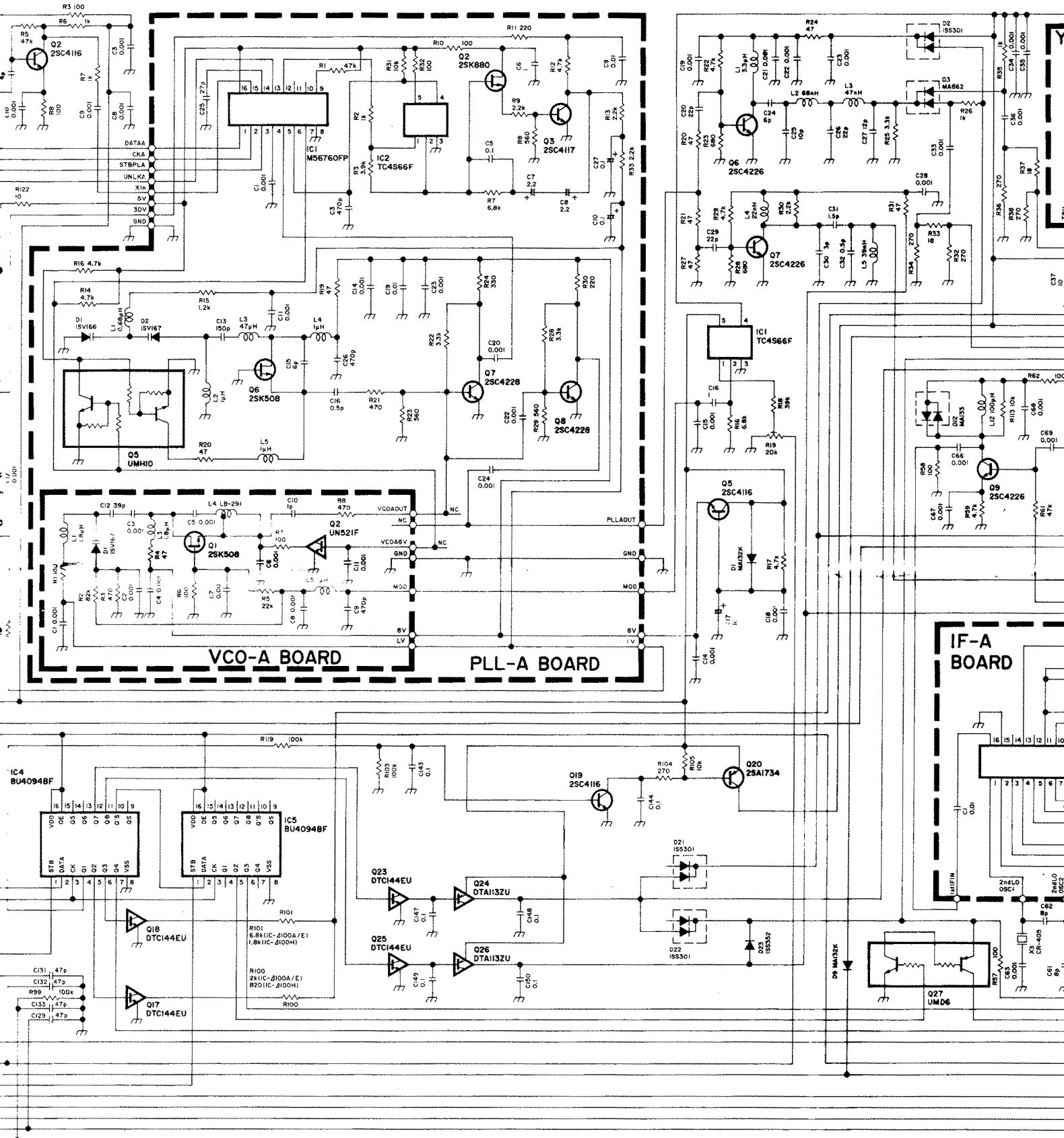

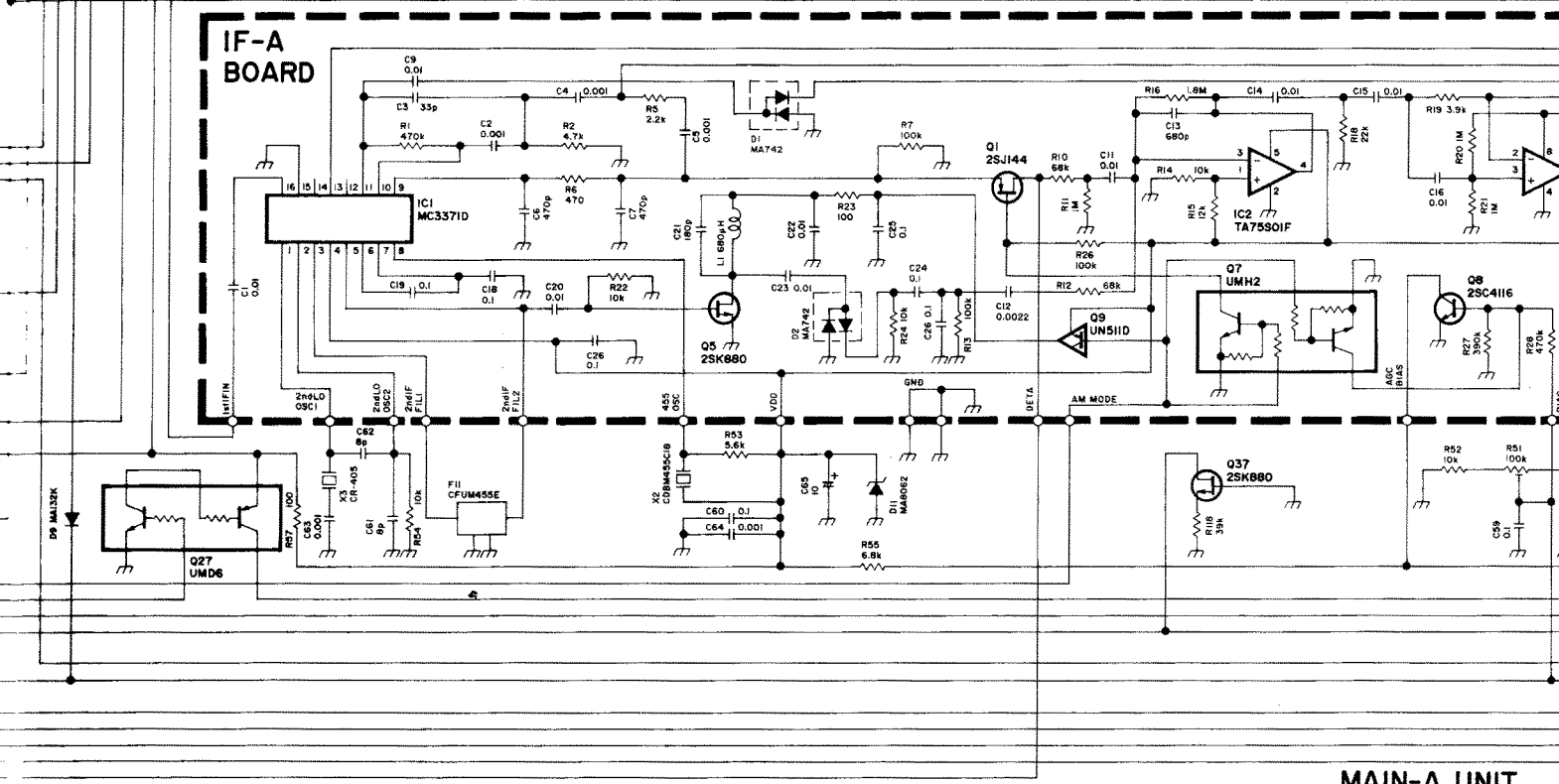
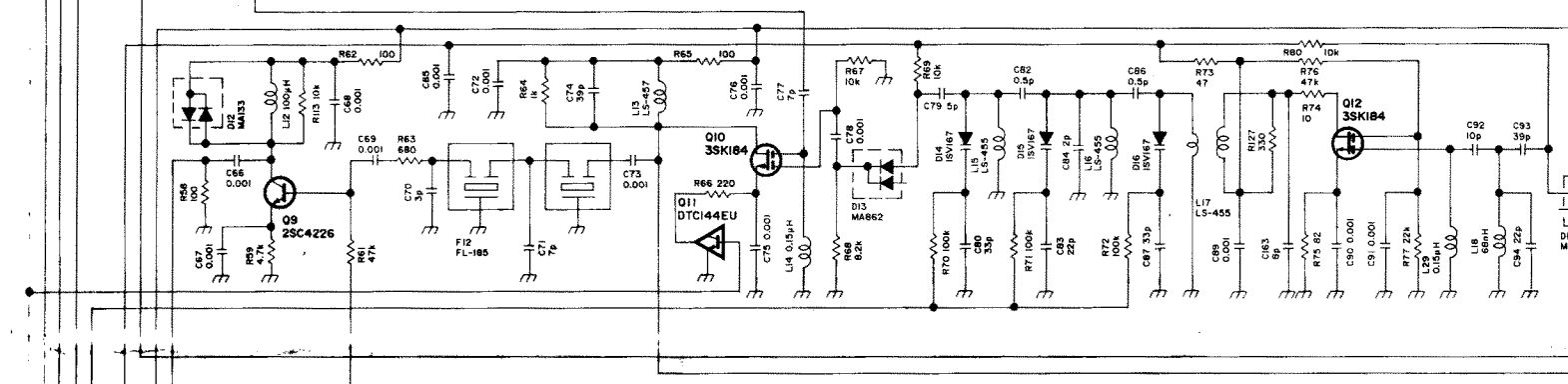
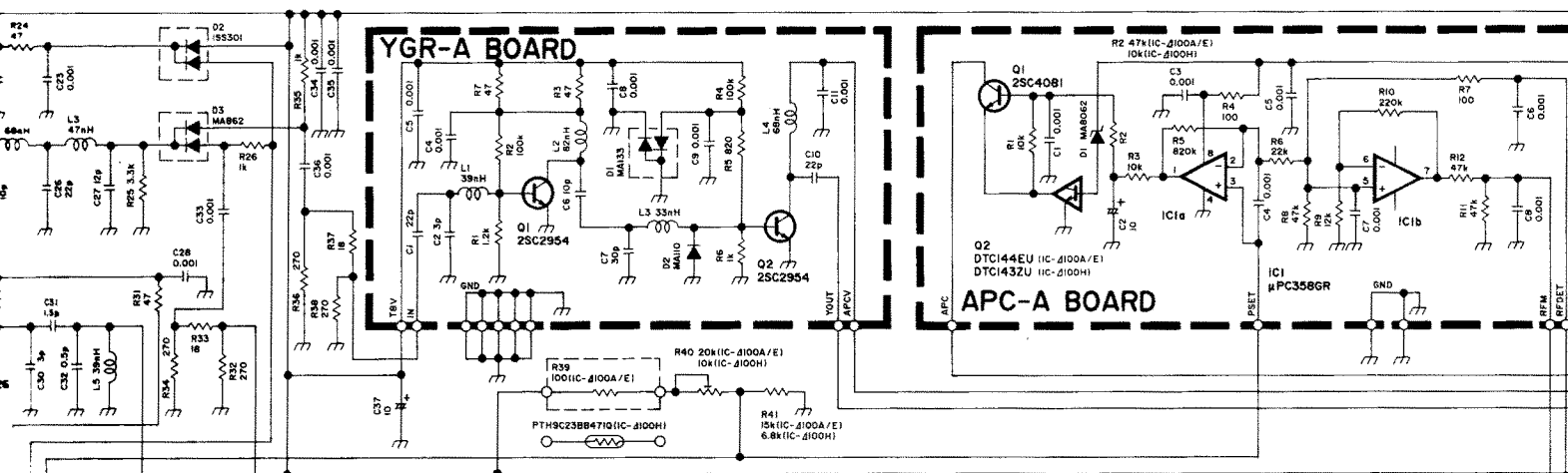

MAIN-A UNIT

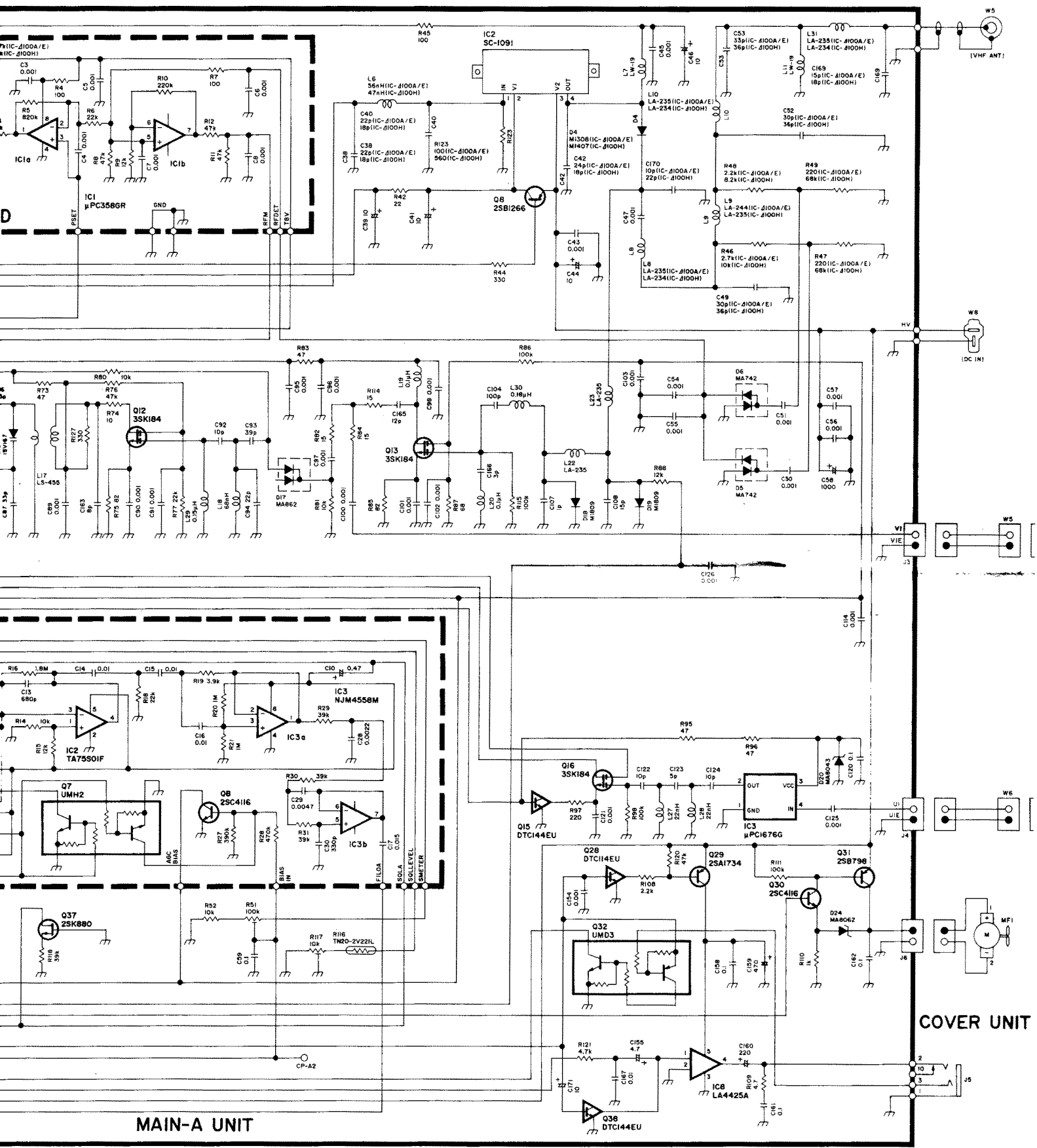

MAIN-A UNIT

COVER UNIT

To upgrade quality, some components may be subject to change without notice.

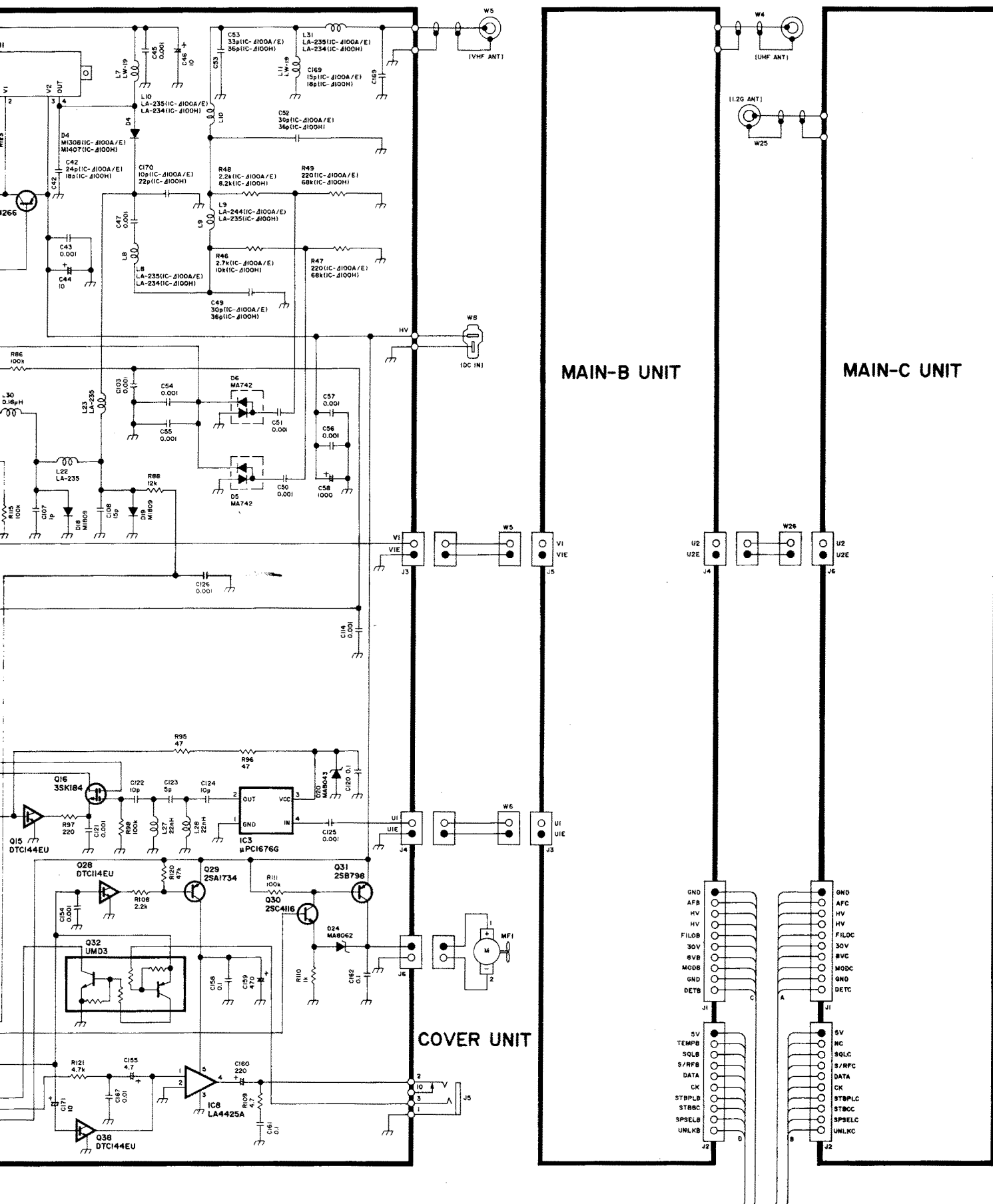

To upgrade quality, some components may be subject to change without notice.

A-5253S-2EX  
 Printed in Japan  
 Copyright © 1993 by Icom Inc.

Icom Inc.

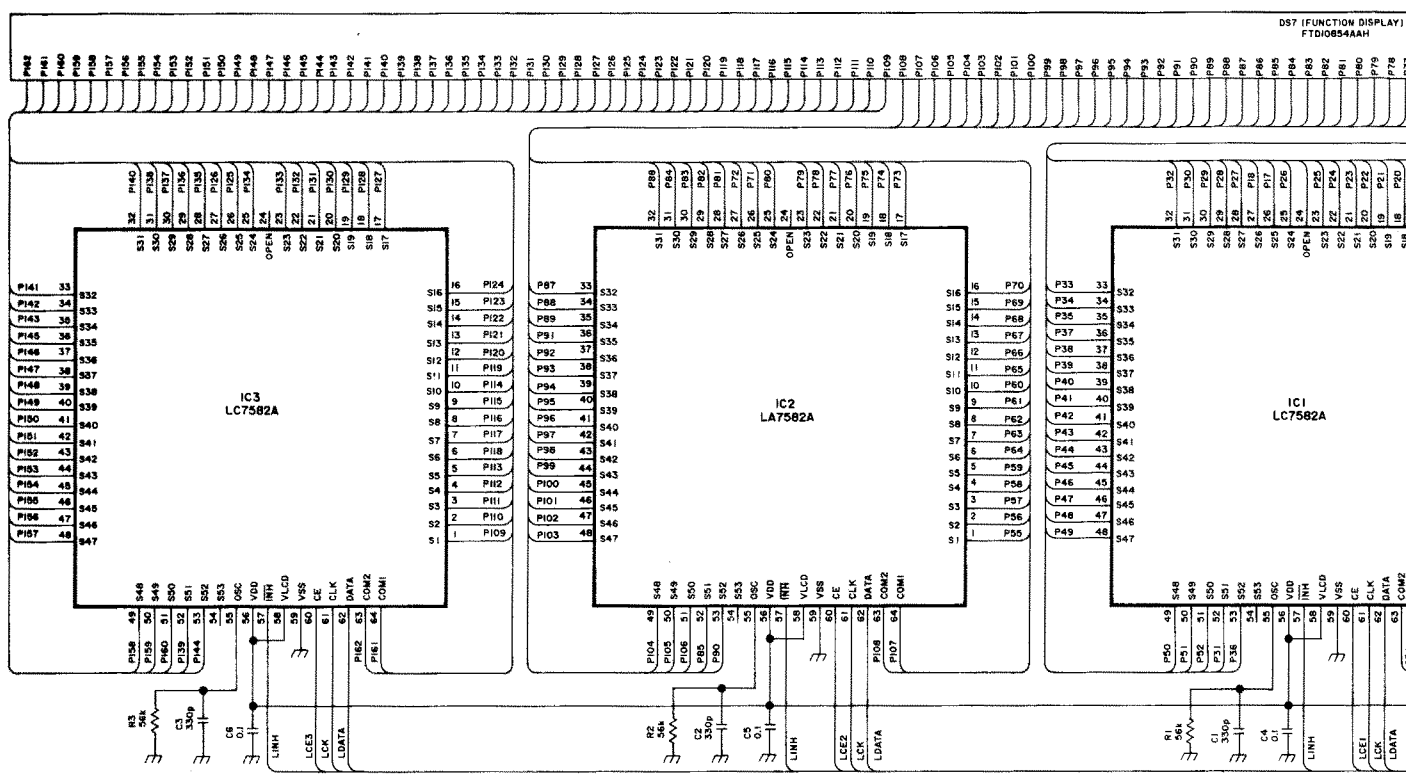

REMOTE CONTROL MICROPHONE HM

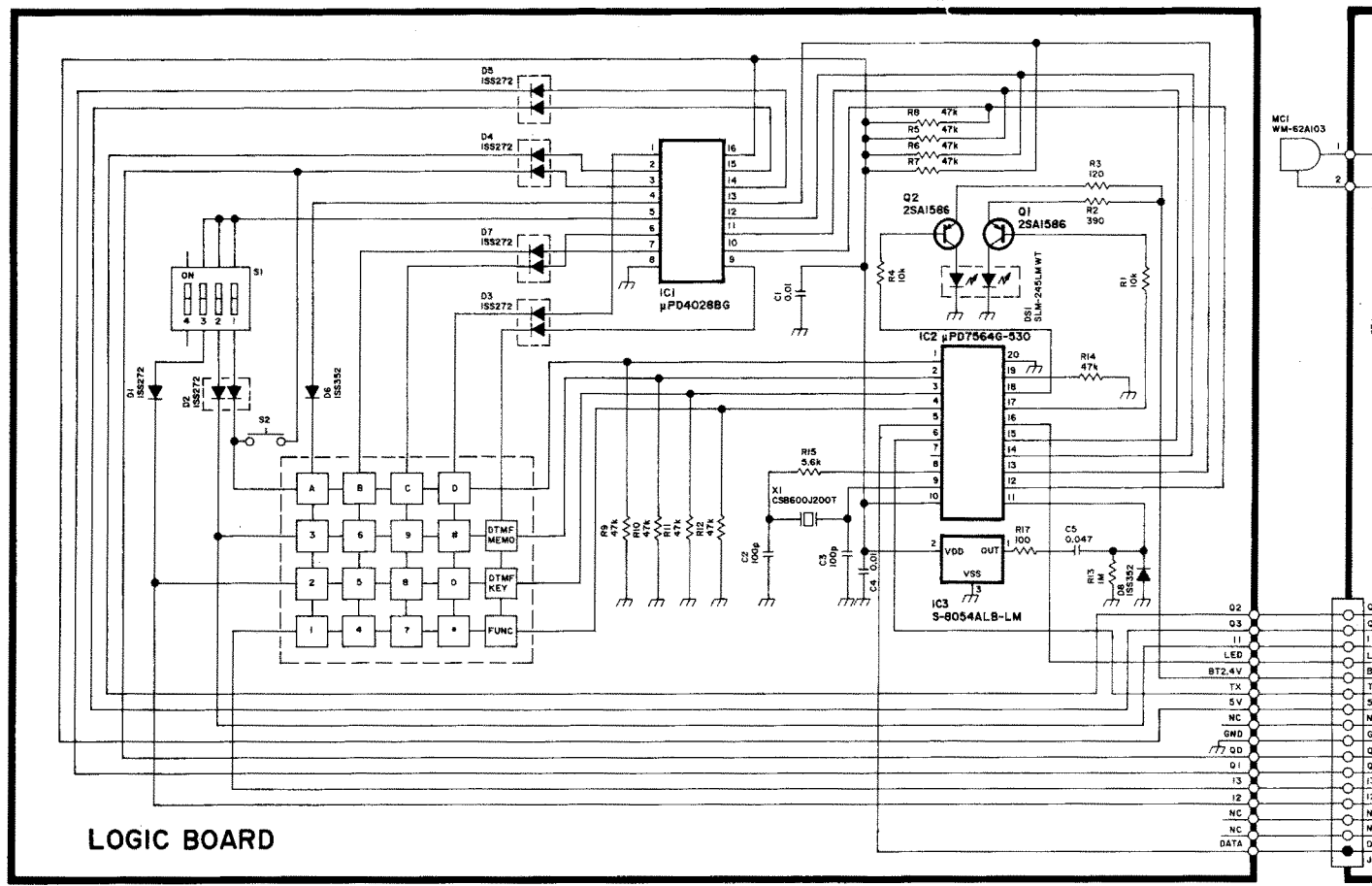



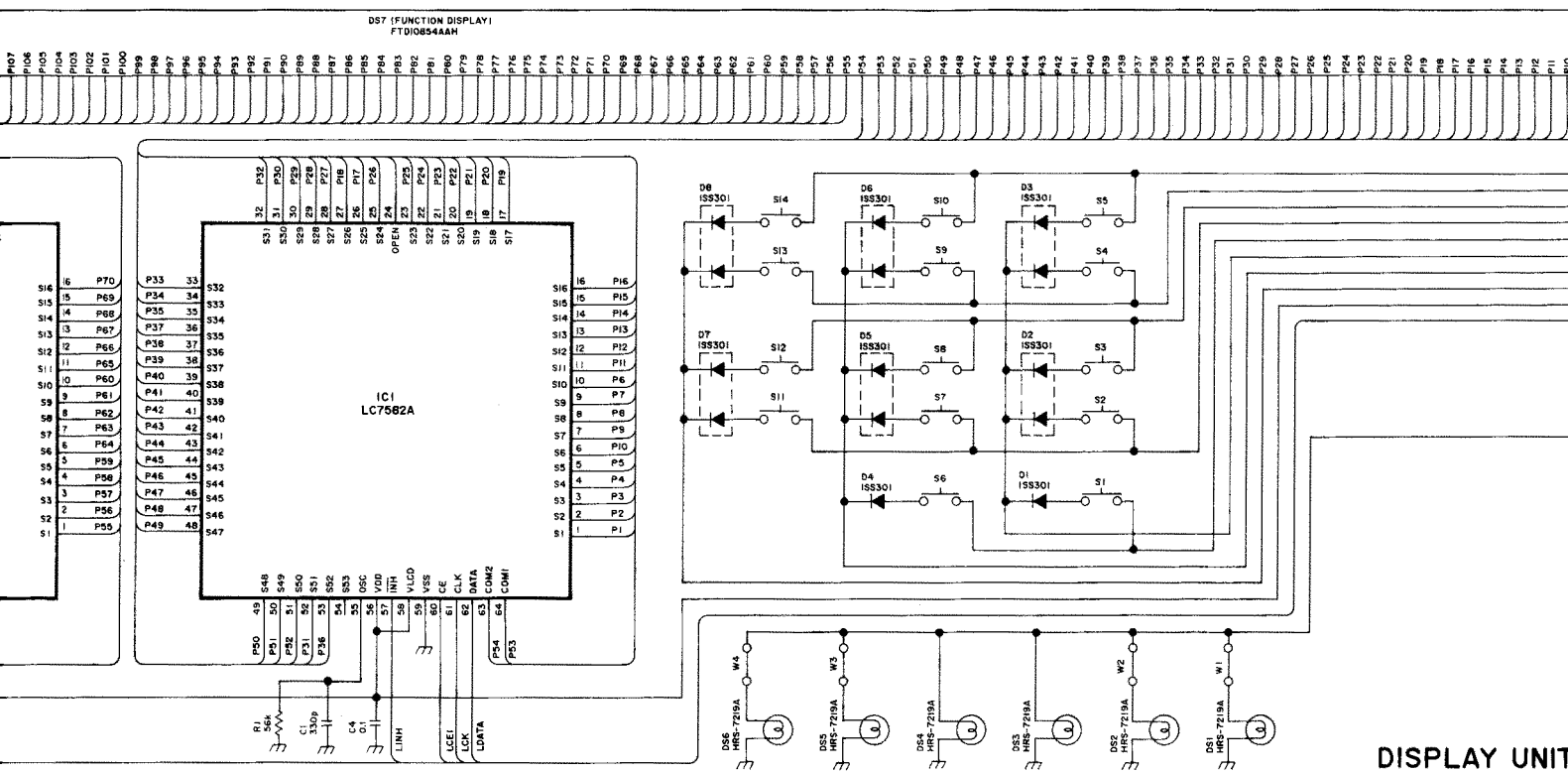

**REMOTE CONTROL MICROPHONE HM-88(EUR/AUS/SEA) / HM-88A(USA)**

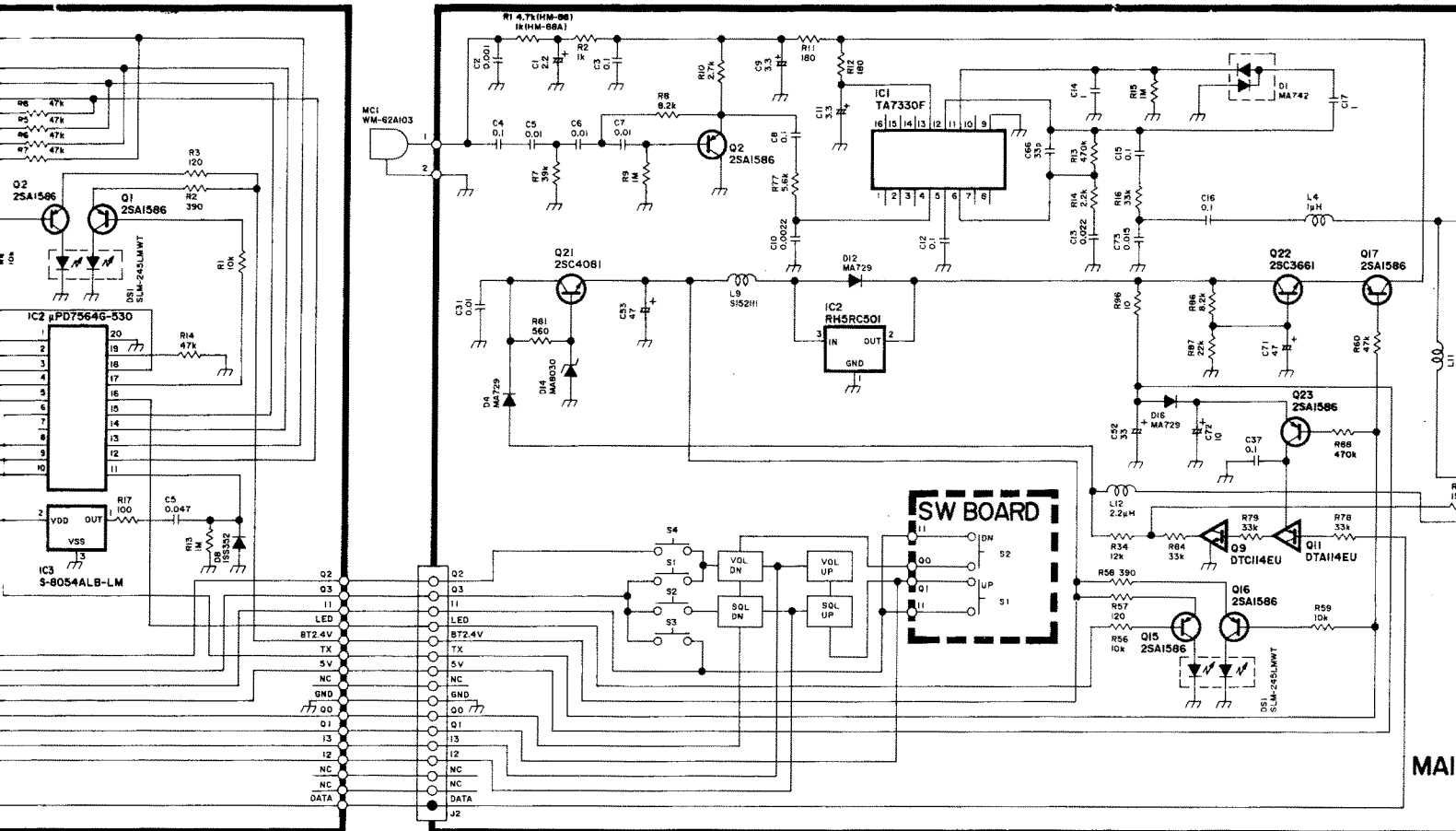

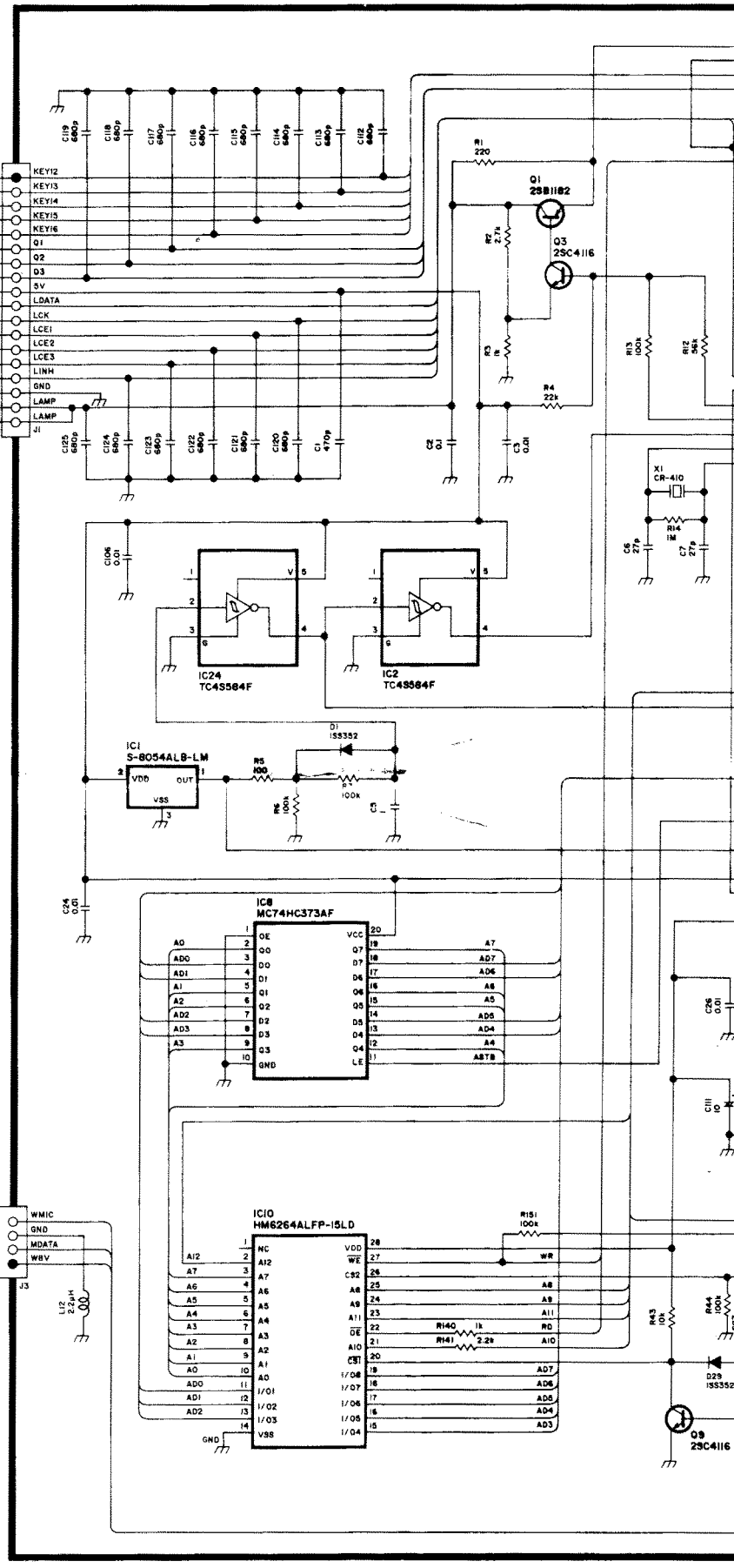
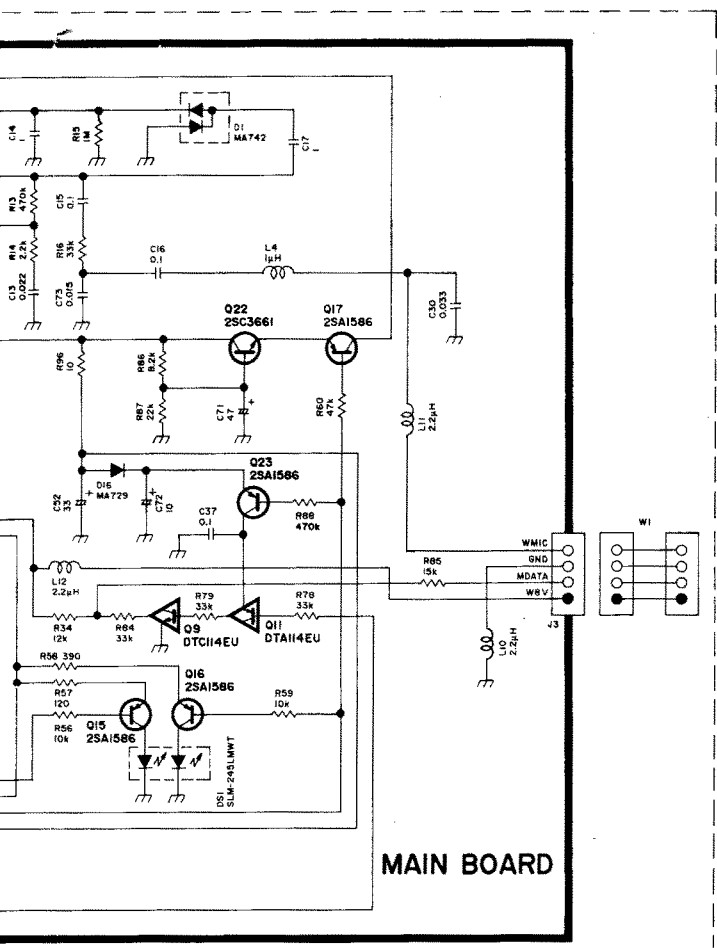
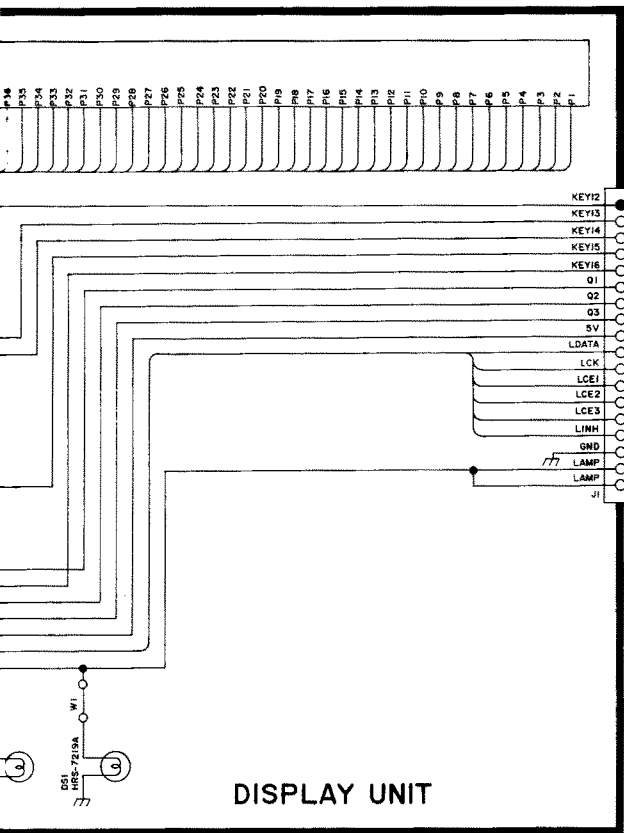

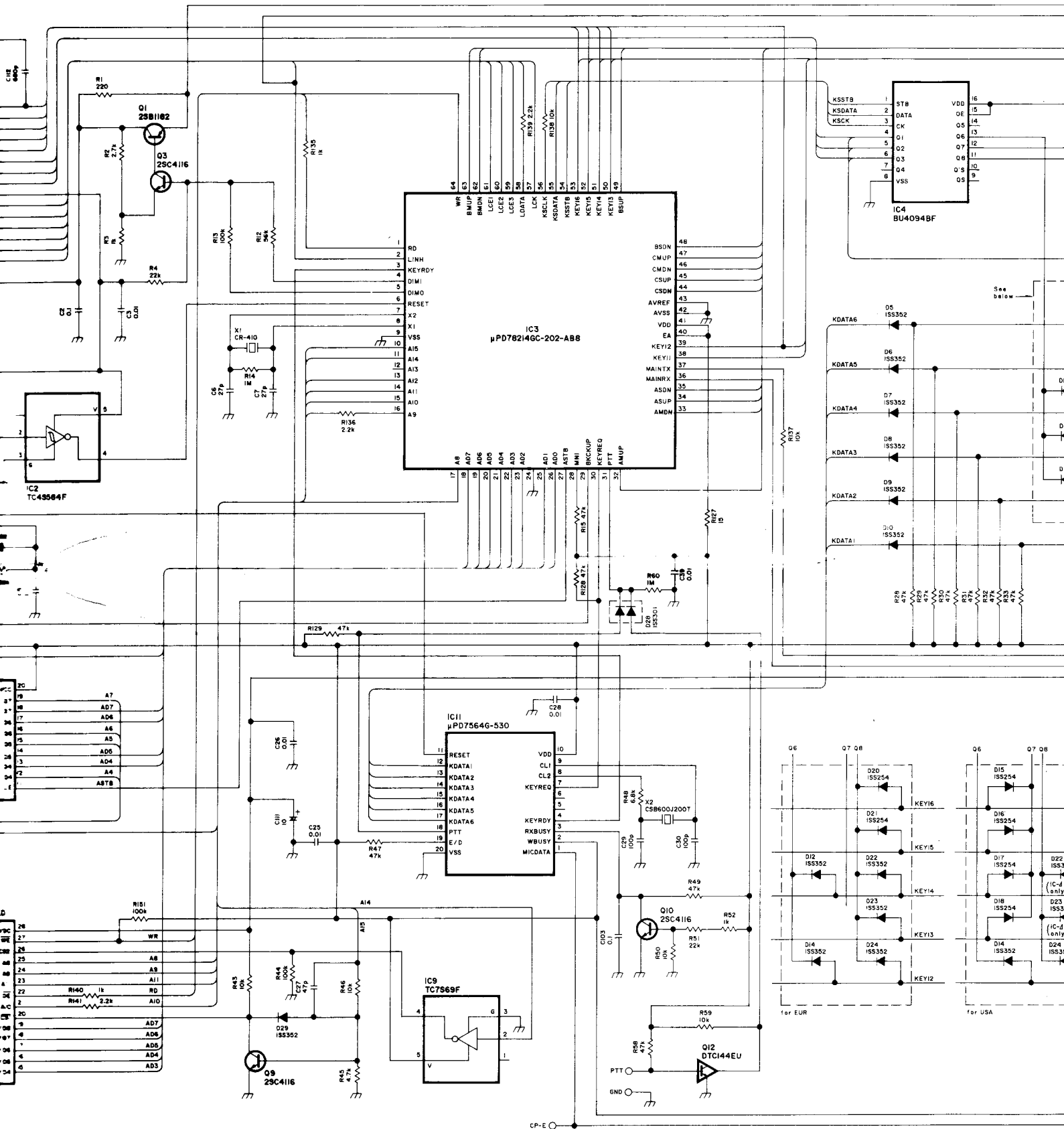

CP-E

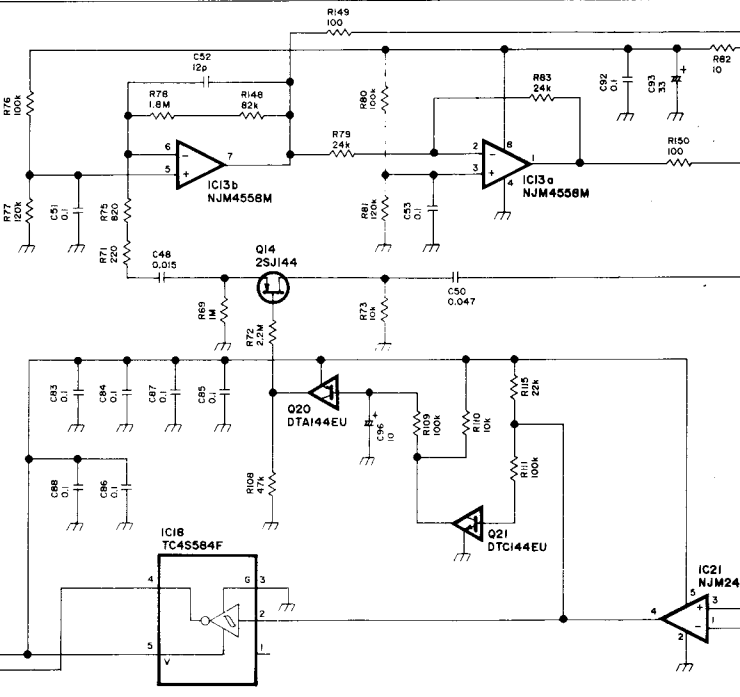
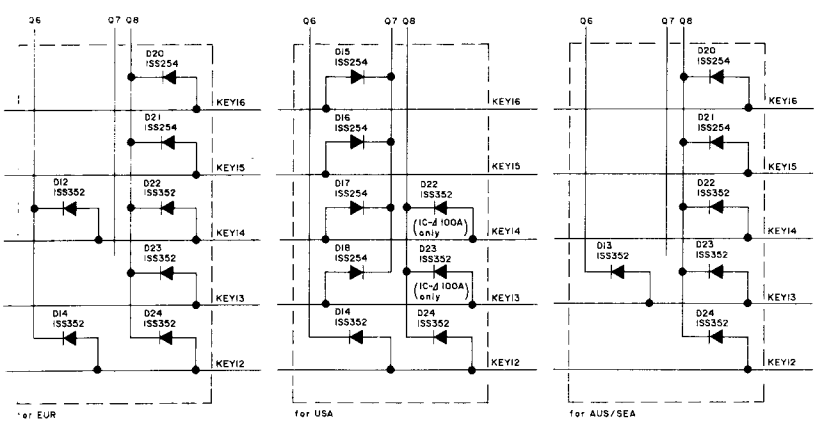
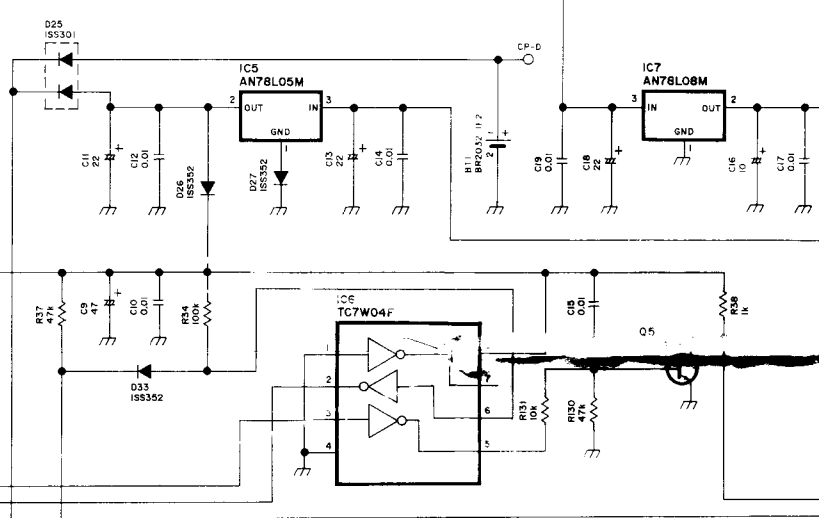
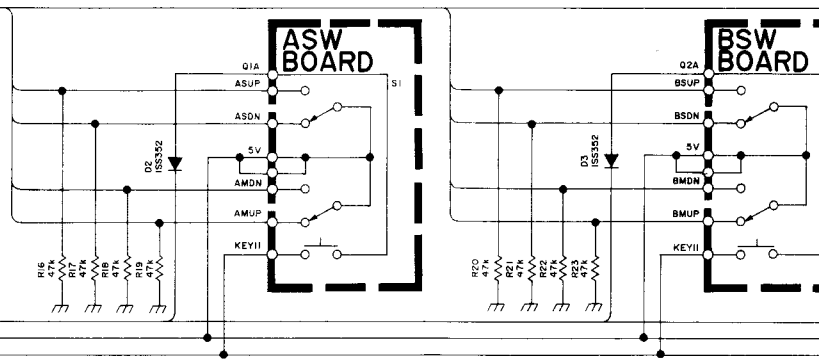
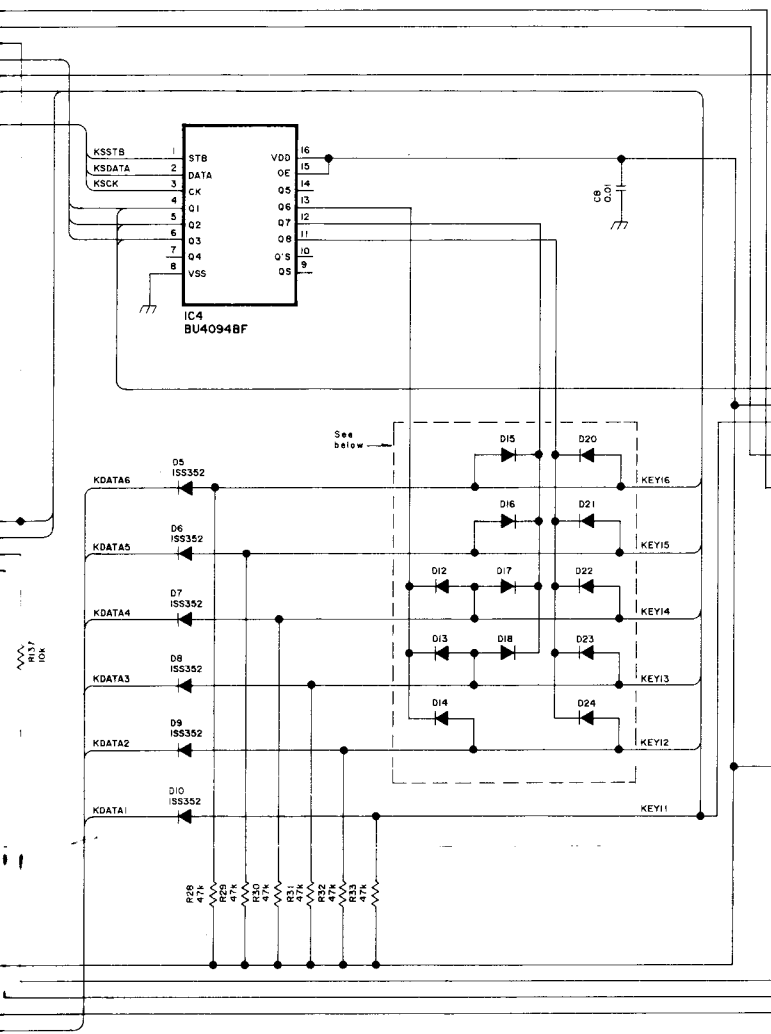

# CONTROL UNIT

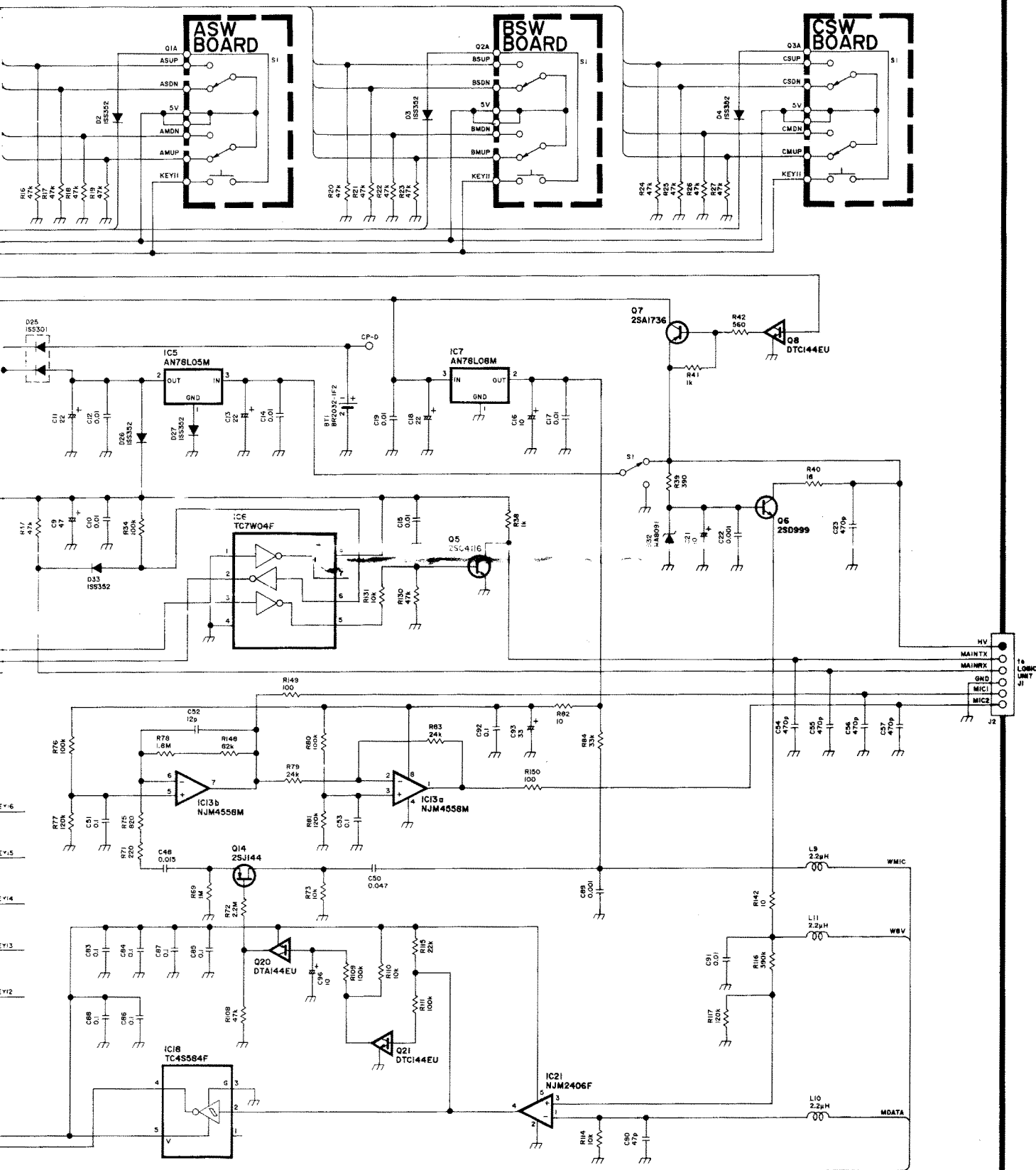

nt on us!

---

---

---

---

---