

NPN SILICON RF POWER TRANSISTOR

DESCRIPTION:

The **MRF846** is Designed for UHF Large-Signal, Common Base Amplifier Applications Up to 960 MHz.

FEATURES INCLUDE:

- Input Matching Network
- Min Gain 4.3 dB
- Gold Metalization

MAXIMUM RATINGS

I_C	14 A
V_{CB0}	36 V
V_{CEO}	16 V
P_{DISS}	150 W @ T _C = 25 °C
T_J	-55 °C to +200 °C
T_{STG}	-55 °C to +150 °C
θ_{JC}	1.17 °C/W

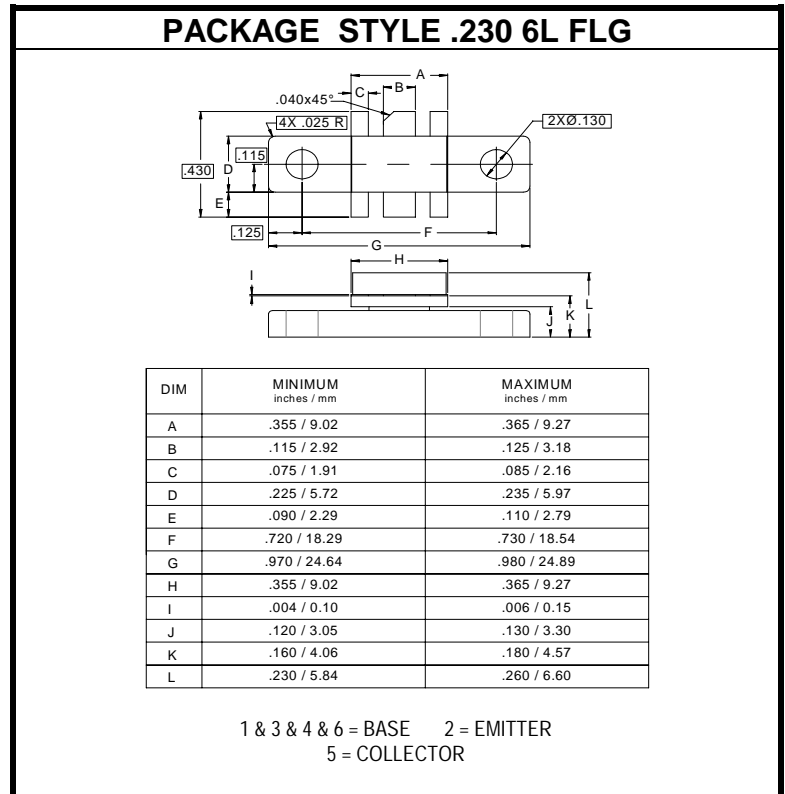
CHARACTERISTICS T_C = 25 °C

SYMBOL	TEST CONDITIONS	MINIMUM	TYPICAL	MAXIMUM	UNITS
BV_{CES}	I _C = 50 mA	36			V
BV_{CEO}	I _C = 50 mA	16			V
BV_{EBO}	I _E = 100 mA	4.0			V
I_{CB0}	V _{CE} = 15 V			10	mA
h_{FE}	V _{CE} = 5.0 V I _C = 2.0 mA	10		150	---
C_{OB}	V _{CB} = 12.5 V f = 1.0 MHz		85	100	pF
P_G	V _{CE} = 12.5 V I _{CQ} = 50mA P _{OUT} = 40 W	4.3	5.2		dB
η_C	f = 870 MHz	50	55		%