

VHF BAND POWER AMPLIFIER APPLICATIONS.

FEATURES :

- Output Power : $P_o=40W$ (Min.)
($f=175MHz$, $V_{CC}=13.5V$, $P_i=10W$)
- 100% Tested for Load Mismatch Stress at All Phase Angles with 30:1 VSWR @ $V_{CC}=13.5V$, $P_i=10W$, $f=175MHz$

MAXIMUM RATINGS ($T_a=25^\circ C$)

CHARACTERISTIC	SYMBOL	RATING	UNIT
Collector-Base Voltage	V_{CBO}	35	V
Collector-Emitter Voltage	V_{CEO}	18	V
Emitter-Base Voltage	V_{EBO}	3.5	V
Collector Current	I_C	10	A
Collector Power Dissipation ($T_c=25^\circ C$)	P_C	70	W
Junction Temperature	T_j	175	$^\circ C$
Storage Temperature Range	T_{stg}	-65 ~ 175	$^\circ C$

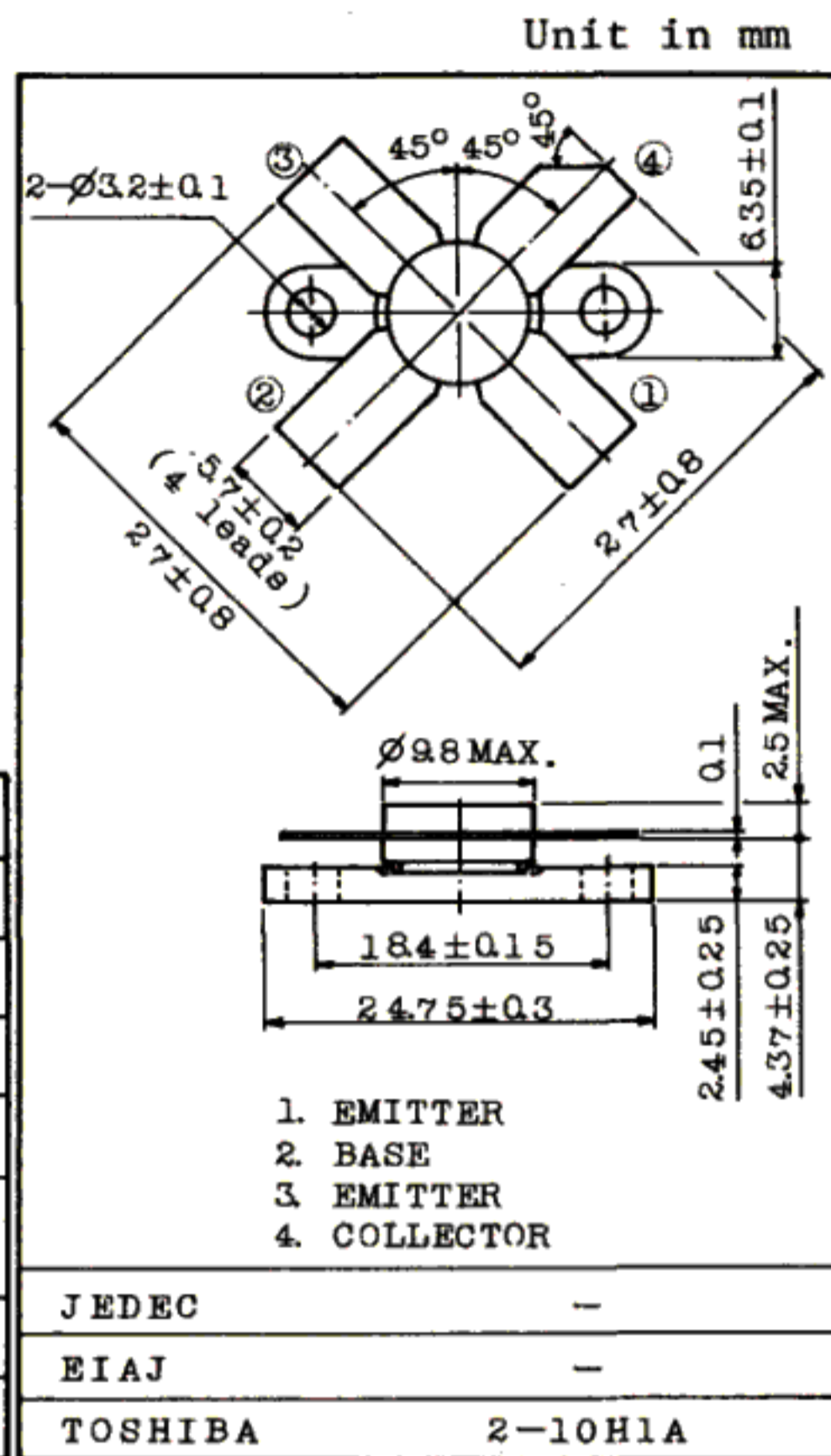

Weight : 4.0g

ELECTRICAL CHARACTERISTICS ($T_a=25^\circ C$)

CHARACTERISTIC	SYMBOL	TEST CONDITION	MIN.	TYP.	MAX.	UNIT
Collector Cut-off Current	I_{CBO}	$V_{CB}=15V$, $I_E=0$	-	-	2	mA
Collector-Base Breakdown Voltage	$V_{(BR)CBO}$	$I_C=20mA$, $I_E=0$	35	-	-	V
Collector-Emitter Breakdown Voltage	$V_{(BR)CEO}$	$I_C=50mA$, $I_B=0$	18	-	-	V
Emitter-Base Breakdown Voltage	$V_{(BR)EBO}$	$I_E=1mA$, $I_C=0$	3.5	-	-	V
DC Current Gain	h_{FE}	$V_{CE}=5V$, $I_C=5A$	10	-	-	
Collector Output Capacitance	C_{ob}	$V_{CB}=10V$, $I_E=0$, $f=1MHz$	-	-	160	pF
Output Power	P_o	(Fig.)	40	44	-	W
Power Gain	G_{pe}	$V_{CC}=13.5V$, $f=175MHz$,	6.0	6.4	-	dB
Collector Efficiency	η_c	$P_i=10W$	60	73	-	%
Series Equivalent Input Impedance	Z_{in}	$V_{CC}=13.5V$, $f=175MHz$,	-	0.95 -j0.1	-	Ω
Series Equivalent Output Impedance	Z_{OUT}	$P_o=40W$	-	2.6 -j0.15	-	Ω

2SC2181

Fig. P_o TEST CIRCUIT

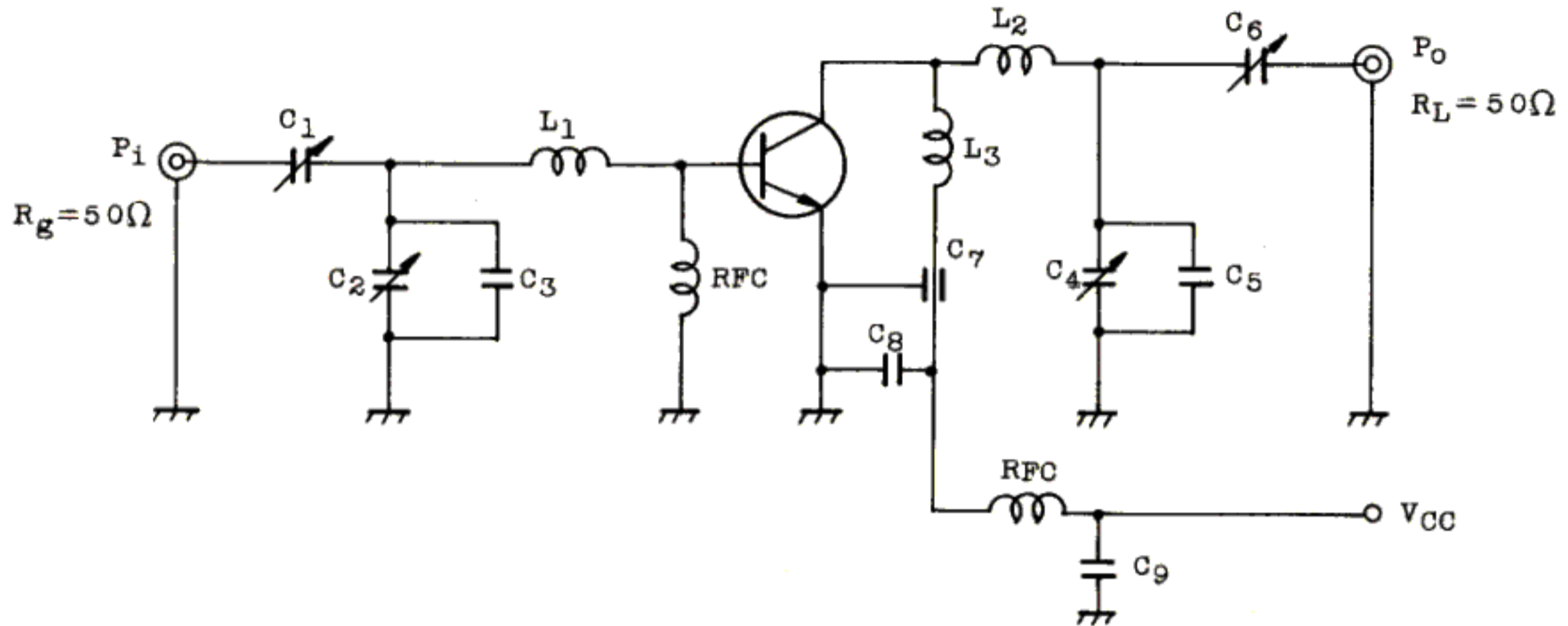

- C_1, C_2, C_4, C_6 : 3.5 ~ 30pF
- C_3, C_5 : 30pF CERAMIC CONDENSER
- C_7 : 1000pF FEED THROUGH
- C_8, C_9 : 0.01 μ F CERAMIC CONDENSER

- L_1 : ϕ 1.2 SILVER PLATED COPPER WIRE, 10ID, 1/2T
- L_2 : ϕ 1.2 SILVER PLATED COPPER WIRE, 10ID, 1T
- L_3 : ϕ 1.2 SILVER PLATED COPPER WIRE, 10ID, 2T
- RFC : ϕ 1.0 ENAMEL COATED COPPER WIRE, 8ID, 10T

