



# SOLID STATE MICROWAVE

2N6080 2N6081  
2N6082 2N6083  
2N6084

THOMSON-CSF COMPONENTS CORPORATION

Montgomeryville, PA 18936 ■ (215) 362-8500 ■ TWX 510-661-7299

## VHF COMMUNICATIONS TRANSISTOR

### DESCRIPTION:

This line of epitaxial silicon NPN-planar transistor is designed primarily for VHF mobile and marine transmitters. The device utilizes emitter ballasting resistors and improved metallization systems to achieve extreme ruggedness under severe operating conditions.

### FEATURES:

- Designed for VHF mobile and marine transmitters
- Withstands severe mismatch under operating conditions
- Low inductance stripline package
- All leads electrically isolated from stud

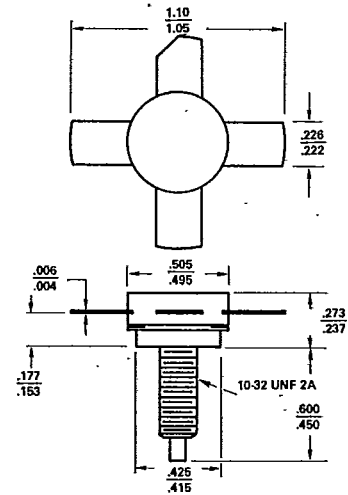

### ABSOLUTE MAXIMUM RATINGS (TA = 25°C)

Symbol	Characteristic	2N6080	2N6081	2N6082	2N6083	2N6084
V <sub>CB0</sub>	Collector to Base Voltage	36.0V	36.0V	36.0V	36.0V	36.0V
V <sub>CEO</sub>	Collector to Emitter Voltage	18.0V	18.0V	18.0V	18.0V	18.0V
V <sub>EBO</sub>	Emitter to Base Voltage	4.0V	4.0V	4.0V	4.0V	4.0V
I <sub>C (max)</sub>	Continuous Collector Current	1.0A	2.5A	4.0A	4.0A	6.0A
P <sub>D</sub>	Total Dissipation at 25°C Stud	12.0W	31.0W	65.0W	65.0W	80.0W
ϕ <sub>JC</sub>	Thermal Resistance (Junction to Stud)	15.0°C/W	5.6°C/W	2.8°C/W	2.8°C/W	2.2°C/W
T <sub>J</sub>	Junction Temperature	-65°C to 200°C	-65°C to 200°C	-65°C to 200°C	-65°C to 200°C	-65°C to 200°C
T <sub>stg</sub>	Storage Temperature	-65°C to 200°C	-65°C to 200°C	-65°C to 200°C	-65°C to 200°C	-65°C to 200°C

### ELECTRICAL CHARACTERISTICS (TA = 25°C)

Symbol	Characteristic	Test Conditions	2N6080		2N6081		2N6082		2N6083		2N6084	
			Min.	Max.	Min.	Max.	Min.	Max.	Min.	Max.	Min.	Max.
BV <sub>CEO</sub>	Collector to Emitter Breakdown Voltage	I <sub>C</sub> = 200mA, I <sub>B</sub> = 0 Pulsed through 25mH	18.V	-	18.V	-	18.V	-	18.V	-	18.V	-
BV <sub>CES</sub>	Collector to Emitter Breakdown Voltage	I <sub>C</sub> = 200mA, V <sub>BE</sub> = 0 Pulsed through 25mH	36.V	-	36.V	-	36.V	-	36.V	-	36.V	-
BV <sub>EBO</sub>	Emitter to Base Breakdown Voltage	I <sub>E</sub> = 2.5mA, I <sub>C</sub> = 0	4.V	-	4.V	-	4.V	-	4.V	-	4.V	-
I <sub>CBO</sub>	Collector Cutoff Current	V <sub>CB</sub> = 15.0V, I <sub>E</sub> = 0	-	1.0mA	-	1.0mA	-	1.0mA	-	1.0mA	-	1.0mA
h <sub>FE</sub>	DC Current Gain	V <sub>CE</sub> = 5V, I <sub>C</sub> = 250mA	5.	-	5.	-	5.	-	5.	-	5.	-
f <sub>T</sub>	Gain Bandwidth Product	V <sub>CE</sub> = 13.6V, I <sub>C</sub> = 100mA f <sub>o</sub> = 100mHz	200.mHz	-	200.mHz	-	200.mHz	-	200mHz	-	200mHz	-
C <sub>ob</sub>	Output Capacitance	V <sub>CE</sub> = 12.5V, I <sub>C</sub> = 0 f <sub>o</sub> = 1mHz	-	20. pF	-	85. pF	-	130. pF	-	130. pF	-	200 pF
P <sub>out</sub>	Output Power Class C	f <sub>o</sub> = 175mHz, V <sub>CE</sub> = 12.5V, Class C	4.W	-	15.W	-	25.W	-	30.W	-	40.W	-
G <sub>pe</sub>	Power Gain Class C	f <sub>o</sub> = 175mHz, V <sub>CE</sub> = 12.5V, Class C	12. dB	-	6.3 dB	-	6.2 dB	-	5.7 dB	-	4.5 dB	-
η	Collector Efficiency	f <sub>o</sub> = 175mHz, V <sub>CE</sub> = 12.5 V, Class C	60.%	-	60.%	-	50.%	-	50.%	-	50.%	-



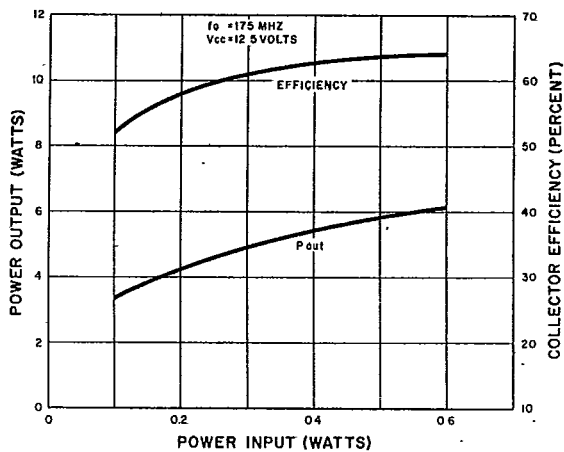

2N6080 POWER OUTPUT VS POWER INPUT

$f_o = 175 \text{ MHz}, V_{cc} = 12.5 \text{ V}$			
P <sub>IN</sub> WATTS	P <sub>OUT</sub> WATTS	INPUT OHMS	OUTPUT OHMS
0.1	3.3	1.5 + j1.7	5.8 + j1.4
0.3	4.9	2.2 + j1.3	7.6 + j9.8
0.5	5.8	2.9 + j0.4	8.4 + j6.9

NETWORK IMPEDANCE AT TRANSISTOR TERMINALS

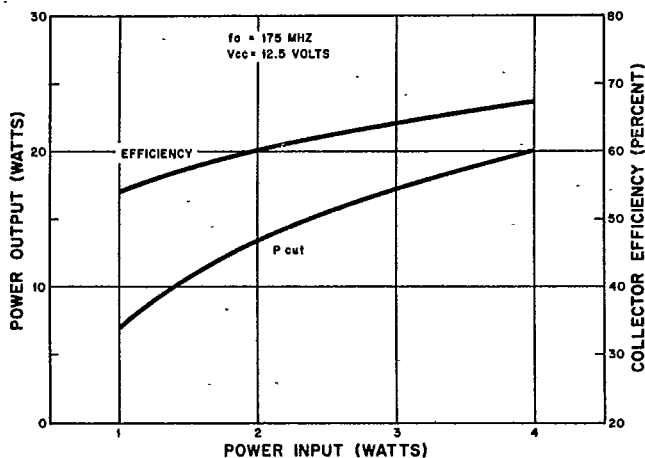

2N6081 POWER OUTPUT VS POWER INPUT

$f_o = 175 \text{ MHz}, V_{cc} = 12.5 \text{ Volts}$			
P <sub>IN</sub> WATTS	P <sub>OUT</sub> WATTS	INPUT OHMS	OUTPUT OHMS
1	9.3	0.8 - j 1.0	4.0 + j 3.0
3	19.6	1.0 - j 1.4	3.3 + j 1.2
5	27.6	1.0 - j 1.0	2.9 + j 0.6

NETWORK IMPEDANCE AT TRANSISTOR TERMINALS

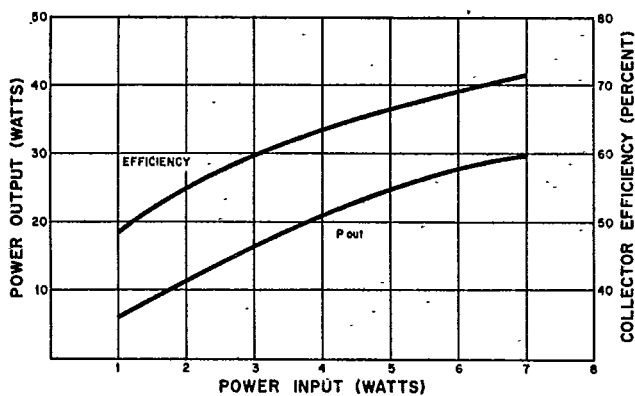

2N6082 - 2N6083 POWER OUTPUT VS POWER INPUT

$f_o = 175 \text{ MHz}, V_{cc} = 12.5 \text{ Volts}$			
P <sub>IN</sub> WATTS	P <sub>OUT</sub> WATTS	INPUT OHMS	OUTPUT OHMS
2.5	17.4	0.8 - j 1.0	2.4 + j 1.5
5.0	27.5	0.9 - j 0.9	2.1 + j 0.4
7.5	35.8	0.9 - j 1.1	2.2 + j 0.1

NETWORK IMPEDANCE AT TRANSISTOR TERMINALS

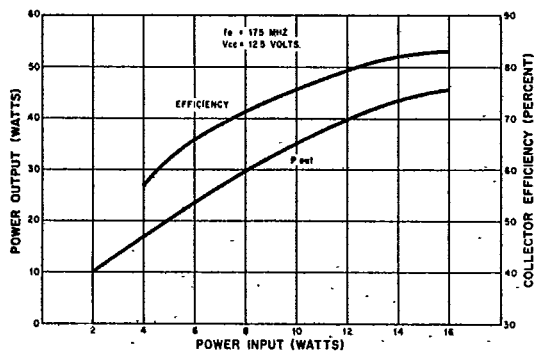

2N6084 POWER OUTPUT VS POWER INPUT

$f_o = 175 \text{ MHz}, V_{cc} = 12.5 \text{ Volts}$			
P <sub>IN</sub> WATTS	P <sub>OUT</sub> WATTS	INPUT OHMS	OUTPUT OHMS
4	21.7	0.8 - j 1.1	2.2 - j 0.3
8	37.1	0.8 - j 1.3	1.7 - j 0.5
12	46.5	0.8 - j 1.6	1.6 - j 0.3

NETWORK IMPEDANCE AT TRANSISTOR TERMINALS

2N6080-2