

uniden®

GRANT XL SSB/AM Citizens Band Mobile Transceiver

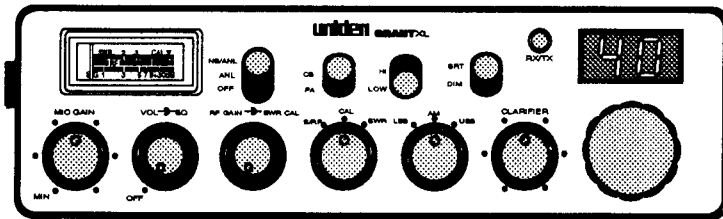

OPERATING GUIDE

Table of Contents

Introduction	1
Elimination of Licensing	1
Unpacking Your CB Radio	2
Controls and Functions	2
Front Panel	2
Rear Panel	6
Multi-Function Meter	7
Installation	8
Mounting the Radio Bracket	8
Mounting the Microphone Hanger	8
Connecting the Power Cord	8
Connecting the Antenna	9
CB Antenna Tips	9
Connecting an External Speaker (Optional)	9
Connecting a Public Address (PA) Speaker (Optional)	9
Operation	10
About SSB	10
Preparation	11
To Receive	11
To Transmit	12
Emergency Operation	12
CB Radio Code Definitions	13
Care and Maintenance	14
Replacing the Fuse in the DC Power Cord	14
Servicing Your CB	14
Troubleshooting	15
Specifications	16
Warranty	

Features, Specifications, and availability of Optional Accessories are all subject to change without notice.

Introduction

Welcome to the exciting world of CB radio communication! Your Uniden **GRANT XL** Citizens Band Mobile Transceiver represents the highest quality communications device designed for use in the Citizens Band Radio Service. This powerful unit operates on any of the 40 AM, 40 LSB, and 40 USB channels authorized by the Federal Communications Commission (FCC), and is type accepted and certified by the FCC.

Among its many features, the **GRANT XL** includes:

- SSB (single-sideband) operation in addition to standard AM operation
- Dual noise reduction circuitry — Noise Blanker and Automatic Noise Limiter
- Multi-function Meter — Measures incoming Signal Strength, RF transmitter output power, and SWR readings
- RF Gain Control — Provides optimum receiving capability in both AM and SSB operating modes
- Adjustable Microphone Gain Control
- Clarifier Control — For fine-tuning of SSB signals
- Public Address System capability

WARNING

The Citizens Band (CB) Radio Service is under the jurisdiction of the Federal Communications Commission (FCC). Any adjustments or alterations which alter the performance of the transceiver's original FCC type acceptance, or change the frequency determining method, are strictly prohibited. Replacement or substitution of crystals, transistors, ICs, regulator diodes, or any other part of a unique nature, with parts other than those recommended by Uniden may cause violation of the technical regulations of Part 95 of the FCC rules or violation of type acceptance requirements of Part 2 of the rules.

Elimination of Licensing

The Federal Communications Commission has ruled that Citizens Band Radio Service operators are no longer required to obtain an FCC license to operate their CB equipment. In doing so, the FCC also permits CB stations to operate without station identification.

Elimination of individual station licenses results in no lessening of the operating privileges or responsibilities of CB users. An operator of a CB radio station is still required to comply with the Communications Act and with the rules of CB Radio Service.

Unpacking Your CB Radio

Carefully check the contents against this list:

- **GRANT XL** SSB/AM Mobile Transceiver
- Microphone
- Microphone hanger kit
- Mounting bracket kit
- DC power cord
- This Operating Guide (read it carefully and save)
- Part 95 Subpart D (FCC Rules)
- Product Registration Form

If any items are missing or damaged, contact your place of purchase immediately.

Be sure to complete and mail in the Product Registration Form.

Controls and Functions

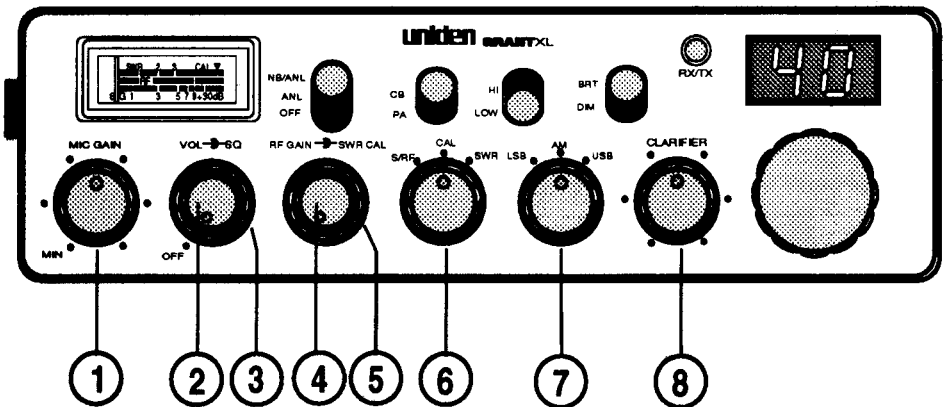

Front Panel

Front Panel

1. **MIC (Microphone) GAIN Control** — Use to adjust the microphone gain during transmitting. At the maximum setting, you have full talk power during transmitting while holding the microphone at a comfortable distance. In the PA (Public Address) mode, this control adjusts the output volume of the PA speaker.
2. **VOL (Volume) Control** — Use to turn the power on or off, and to adjust the receiving audio level.
3. **SQ (Squelch) Control** — Use to eliminate background noise during the absence of a signal. Turn the Squelch Control fully counterclockwise, then slowly rotate it back clockwise until all noise disappears. At this setting, any signal must be slightly stronger than the background noise to break squelch and be heard. Rotating the control farther clockwise increases the threshold level below which weak signals are not heard. At the maximum clockwise setting, only the strong signals can break squelch and be heard.
4. **RF GAIN Control** — For normal operation, keep the RF Gain Control at the full clockwise position. Turn counterclockwise to reduce incoming signal gain when a signal is strong enough to saturate your receiver.
5. **SWR CAL Control** — Use to calibrate the meter for SWR (standing-wave ratio) measurements. Make sure the Mode Selector (7) is set to the **AM** position. Turn the Meter Selector (6) to the **CAL** position. Press and hold the microphone PTT (push-to-talk) Switch. Turn the SWR CAL Control to adjust the needle to the ▼ position on the SWR meter. Then turn the Meter Selector to the **SWR** position to measure the standing-wave ratio of your antenna system. A lower reading indicates better antenna matching.
6. **Meter (S/RF CAL SWR) Selector** — Use to select the function of the meter. For normal operation, always set to the **S/RF** position. The **SWR** and **CAL** positions are for SWR measurement only. (See "Multi-Function Meter" on page 7 for related information.)
7. **Mode (LSB AM USB) Selector** — Use to select the mode of operation (AM, LSB, or USB) for both the transmitter and receiver. In SSB (single-side band) mode you are allowed to transmit 12 watts PEP power. Therefore, you can communicate at far greater distances than with conventional AM mode operation. Because not all the CBers are equipped with SSB mode, you can always select AM mode for normal CB communications. (For more details, see "About SSB" in the Operation section.)
8. **CLARIFIER Control** — Use to fine-tune the SSB receiving signals. The Clarifier Control is provided primarily for SSB mode operations. It can also be used in AM mode operation to optimize receiving signals.

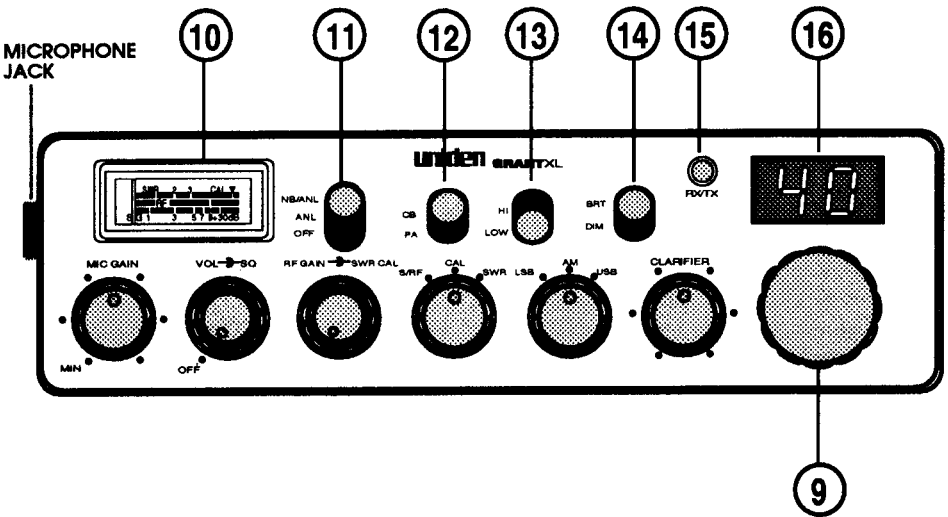

Front Panel

9. **Channel Selector** — Turn this knob to select any one of the 40 channels desired. The selected channel is displayed on the LED readout, directly above the channel selector knob. Use Channel 9 for emergency communication only. Because Channel 9 is reserved for emergency operation only, you cannot transmit on this channel for non-emergency purposes. However, you may monitor Channel 9 anytime you wish to do so.

Important: All channels, except Channel 9, may be used for normal communication. Channel 9 is reserved by the FCC for emergency communications involving the immediate safety of individuals or the protection of property. Channel 9 may also be used to render assistance to a motorist. *This is an FCC rule and applies to all operators of CB radios.*

10. **Multi-function Meter** — This meter has three separate functions:

- S-meter
- RF meter
- SWR meter

For a description of these functions, see 'Multi-Function Meter' on page 7.

11. **NB and ANL Switch** — Activates noise reduction circuitry. At the **ANL** (Automatic Noise Limiter) position, only ANL circuitry is activated in the audio to reduce background white noise. At the **NB/ANL** position, this switch activates both the ANL and NB (Noise Blanker) circuitry in the receiver. The NB circuitry is very effective for repetitive impulse noise, such as ignition noise. In the **OFF** position, NB and ANL circuits are deactivated.
12. **CB/PA Switch** — For normal CB operation, keep this switch at the **CB** position. If you connect a PA (Public Address) speaker (optional) to the **PA. SP. Jack** on the rear panel, set the switch to the **PA** position. This enables you to use the radio as a public address system. In PA mode, your voice will be heard through the PA speaker. Also, all incoming signals will be heard through the PA speaker. This allows you to monitor your channel activity while you are outside your vehicle. Adjust the PA speaker output volume with the **Microphone Gain Control**.
13. **HI/LOW Switch** — This switch allows you to select the tone of the receiving voice in the audio. The **LOW** position increases bass. The **HI** position increases treble.
14. **BRT/DIM Switch** — This switch allows you to change the brightness of the channel LED and meter lighting. The **DIM** position lowers the brightness, and may be more suitable for night driving.
15. **RX/TX Indicator** — This 2-color LED lights to indicate the RX (receive mode) or TX (transmit mode). The LED is **GREEN** for RX, and **RED** for TX. The LED turns off when pressing the microphone PTT Switch in the PA mode.
16. **Channel Readout** — This bright LED displays the selected channel number.

Microphone Jack — Connect the microphone to this jack in order to operate either the receiver or transmitter. If the microphone is not connected, you will hear no audio from the speaker.

Microphone — Set the Microphone Gain Control to the full clockwise position. Press and hold the PTT (push-to-talk) Switch, and hold the microphone several inches away from your mouth. Speak into the microphone clearly in a normal voice. When you are finished talking, release the PTT Switch immediately to receive the responding transmission.

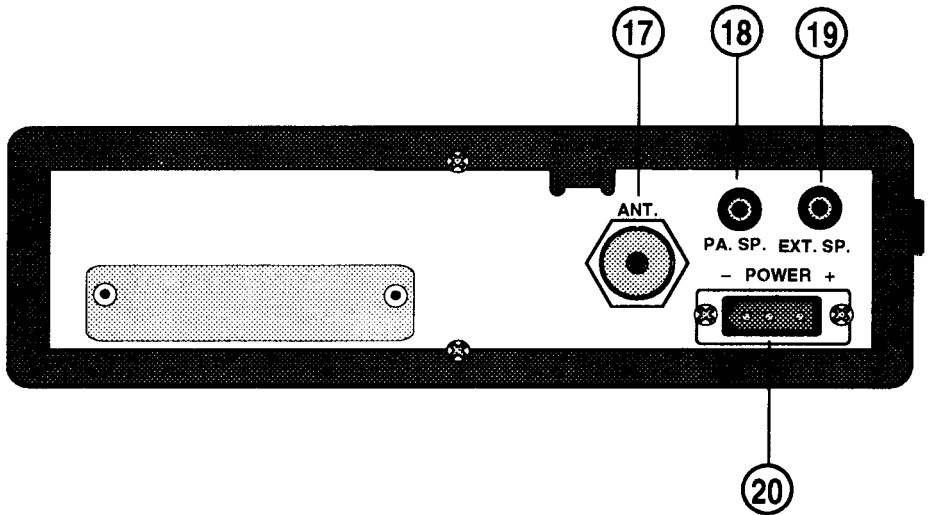

Rear Panel

Rear Panel

17. **ANT. (Antenna) Connector** — Connect the antenna coaxial cable here.
(Note: Antenna and cable with connectors are not included.)
18. **P.A. (Public Address) Speaker Jack** — Connect an optional Public Address speaker here. For the PA speaker, use an 8Ω speaker with at least a 4-watt rating. Be sure the PA speaker is directed away from the microphone to avoid acoustic feedback. When you are operating the PA system with high output level, greater separation and acoustic isolation between the microphone and PA speaker may be required to prevent feedback. When this unit is used as a public address system, set the CB/PA Switch to the **PA** position.
19. **EXT. SP. (External Speaker) Jack** — Connect an optional external speaker here. For the external speaker, use an 8Ω speaker with at least a 4-watt rating. When an external speaker plug is connected to this jack, it automatically disables the internal speaker. This jack is provided for high performance remote receiver monitoring.
20. **POWER Connector** — Connect the supplied DC power cord here. The DC power cord has a mating plug attached to ensure the proper polarity connection. This easy-to-detach feature is useful whenever the unit needs to be stored in a secure place.

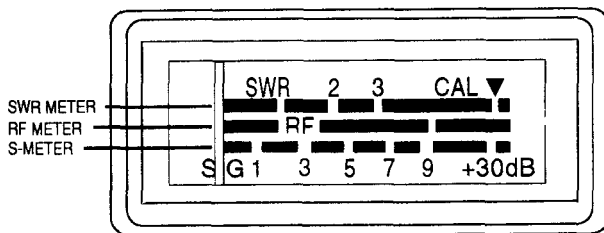

Multi-function Meter

Multi-Function Meter

- **S-meter:** Measures the signal strength of the incoming signal. To use the S-meter, position the Meter Selector at **S/RF**. The meter swings to indicate the level of an incoming signal strength.

Examples of the S-meter readings are: S 3, S 5, S 7

- **RF Meter:** RF output power meter for the transmitter. To use the RF Meter, position the Meter Selector at **S/RF**. Press the microphone PTT Switch to read your transmitting RF power.
- **SWR Meter:** Measures the SWR (standing-wave ratio) of your antenna system. Use the SWR Meter to adjust the antenna to proper length or to check your antenna system. To measure SWR:
 1. Set the Mode Selector to the **AM** position.
 2. Set the Meter Selector to the **CAL** position.
 3. Press and hold the microphone PTT Switch. (Transmit)
 4. Calibrate the meter using the SWR CAL Control. (Adjust the needle to the ▼ mark.) Do not talk into the microphone or set the Microphone Gain Control to the **MIN** position.
 5. Move the Meter Selector to the **SWR** position while holding the PTT Switch.

A reading below **2** is adequate. Any higher reading indicates that the problem exists in your antenna system. The problem can be caused by humidity, vibration, or corrosion. Check for breakage or damage to the cable, coaxial cable, and/or antenna.

Installation

Mounting the Radio Bracket

1. Select an ideal location in your vehicle to mount the **GRANT XL**. Make sure the location will not interfere with your driving. In a passenger car, the ideal installation is underneath the dashboard on the passenger side.
2. Remove the mounting bracket from the radio and use it as a template for marking the location of the mounting screws. (**Note:** If there are screws already holding the dashboard, you may be able to use the same screw holes to mount the bracket.)
3. Drill the necessary holes and secure the mounting bracket in place using the screws provided.
4. Mount the radio to the bracket only after the wiring has been connected to the rear panel and the microphone hanger has been installed.

Mounting the Microphone Hanger

Mount the microphone hanger to the side of the radio. Mounting holes are provided near the microphone connector and on the other side of the unit. Use the screws supplied. You can also mount the hanger on the dashboard, if preferred.

Connecting the Power Cord

1. Check the vehicle battery connections to determine which battery terminal (positive or negative) is grounded to the engine block or chassis. Most of today's vehicles use a negative ground. If your vehicle has a negative ground, follow steps 2 and 3.
2. Connect the **RED** wire of the DC power cord to the accessory contact in your vehicle's +13.8 VDC fuse box.
3. Connect the **BLACK** wire of the DC power cord to the negative side of the automobile (usually the chassis).

Note: *In vehicles with a positive ground, the RED wire connects to the chassis and the BLACK wire connects to the accessory contact in the fuse box.*

4. Plug the DC power cord into the Power Connector on the rear panel.

Connecting the Antenna

Connect the CB antenna plug to the Antenna Connector on the rear panel. (For more information on antenna installation, please refer to the instruction guide that came with your antenna.)

CB Antenna Tips

- A vertically polarized quarter-wavelength whip antenna provides the most reliable operation and greatest range. The shorter loaded-type whip antennas are more attractive and compact than the larger full quarter-wavelength whip. Although the reduced height decreases possible clearance problems, the shorter antennas may not provide the same transmitting and receiving range possible with the longer ones.
- A 3-way combination antenna allows you to operate all three bands (AM, FM, and CB) with one antenna. However, it will provide a shorter transmitting and receiving range than a standard "single band" antenna designed for CB use only. You may also notice a higher SWR with this type of antenna.

Connecting an External Speaker (Optional)

Connect an optional external speaker to the External Speaker Jack on the rear of the transceiver. For the external speaker, use an 8 Ω speaker with at least a 4-watt rating. When connected, the external speaker automatically disables the internal speaker. The external speaker will provide high performance remote receiver monitoring.

Connecting a Public Address (PA) Speaker (Optional)

Connect an optional Public Address speaker to the PA Speaker Jack on the back of the transceiver. For the PA speaker, use an 8 Ω speaker with at least a 4-watt rating. Be sure the PA speaker is directed away from the microphone to avoid acoustic feedback. When you are operating the PA system with high output level, greater separation and isolation between the microphone and PA speaker may be required to prevent feedback. When this unit is used as a public address system, set the CB/PA Switch to the PA position.

Operation

Before operating the **GRANT XL**, be sure you have read and understood **Part 95** of the **FCC rules and regulations**.

About SSB

Your **GRANT XL** can communicate in two different modes: **AM** and single-sideband (**SSB**). In **AM** mode, you can receive and transmit standard **Amplitude Modulated CB** signals in the assigned **40 CB** channels. Although this may work well for most of your communications, you also have the option of receiving and transmitting **80 single-sideband channels** (**40 upper sideband** and **40 lower sideband**).

Since **SSB** (**single-sideband**) modes are allowed to transmit **12 watts PEP** power, you can communicate at greater distances than with conventional **AM** mode operation. Because not all the **CBers** are equipped with **SSB** mode, you can always select **AM** mode for standard communications.

The standard **AM** signal is composed of a carrier frequency and two other frequencies (**sidebands**) carrying the audio information. In single-sideband communications, the carrier frequency and one of the sidebands are suppressed, and only the other sideband is received and transmitted. You can operate on either **USB** (**upper sideband**) or **LSB** (**lower sideband**). With **SSB**, you gain increased effective power without losing any information. You also gain **80 more channels** for communications.

To communicate with another transceiver in the **SSB** mode, you must both be on the same sideband, **USB** or **LSB**.

If you hear a "garbled" signal on your **CB**, you may be listening to **SSB** transmission. Set the **Mode Selector** to **LSB** and listen. If the signal is still garbled, or has disappeared, try **USB**. Once you are in the correct mode, use the **Clarifier Control** to "fine-tune" the signal. You will now be able to communicate with the transmitting party.

If you are having trouble with adjacent interference, or if too many stations are on the same frequency, you may want to suggest **SSB** mode to the station you are communicating with.

Preparation

1. Be sure that the power cord, antenna, and microphone are properly connected.
2. Make sure the CB/PA Switch is set to **CB**.
3. Set the Mode Selector to **AM**. (Generally, AM mode is used unless you are communicating with a station equipped with SSB capability, as described previously. Remember: In order to communicate, you must be in the same mode as the other party.)
4. Set the RF Gain Control fully clockwise to the end.
5. Set the Microphone Gain Control fully clockwise to the end.
6. Set the Clarifier Control to the center position.
7. Set the Squelch Control fully *counterclockwise*.
8. Set the Meter Selector to the **S/RF** position.
9. Turn the power on by rotating the Volume Control.

To Receive

1. Adjust the volume to a comfortable listening level.
2. Turn the Channel Selector to the desired channel.
3. Set the NB/ANL Switch to the optimum position.
4. If you prefer to hear no background noise during the absence of an incoming signal, adjust the squelch. To do this, first turn the Channel Selector to an open channel where there is only constant noise. Then, turn the Squelch Control *clockwise* slowly until the noise just disappears. (No signal should be present while adjusting the squelch.) Leave the control at this setting. The receiver will remain quiet until a signal is actually received. Changing the channel should not affect this squelch setting.

Note: *Do not advance the Squelch Control too far, or some weaker signals will not be heard.*

5. If an incoming signal (i.e., the sender's voice) is distorted, set the Mode Selector from **AM** to either **LSB** or **USB**, whichever provides the clearest signal.

To Transmit

1. Set the Channel Selector to the desired channel.
2. Make sure the Microphone Gain Control is set fully clockwise to the end.
3. If the channel is clear, press the PTT Switch on the microphone to talk. Hold the microphone a few inches away from your mouth and speak clearly.







Note: *If the channel is busy, do not transmit until it becomes clear.*

Emergency Operation

1. Turn the Channel Selector to Channel 9. Your **GRANT XL** is now in Emergency Channel Operation mode.
2. If the channel is clear, press the PTT Switch on the microphone to talk. Hold the microphone a few inches away from your mouth and speak clearly.
3. It is possible that your present location is out of range of those who monitor Channel 9. If there is no response to your emergency call on Channel 9, turn the Channel Selector to find an active channel. Ask the party on that channel for assistance in relaying your emergency message on Channel 9 in their area.
4. When emergency communication is no longer needed, be sure to switch back to any of the normal channels.

Rules You Should Know

When operating your CB, there are a few important rules to observe:

-  It is prohibited to carry on a conversation with another station for more than 5 minutes at a time without taking a 1-minute break, to give others a chance to use the channel.
-  It is prohibited to blast others off the air by over-powering them with illegally amplified transmitter power or illegally high antennas.
-  You must not use the CB to promote illegal activities.
-  It is illegal to use profanity.
-  You may not play music in your CB.
-  You may not use your CB to sell merchandise or professional services.

CB Radio Code Definitions

The following list contains many of the common "10-Codes" used by CB radio operators for faster communication and better understanding.

Code	Meaning	Code	Meaning
10-1	Receiving poorly	10-35	Confidential information
10-2	Receiving well	10-36	Correct time is
10-3	Stop transmitting	10-37	Wrecker needed at
10-4	OK, message received	10-38	Ambulance needed at
10-5	Relay message	10-39	Your message delivered
10-6	Busy, stand by	10-41	Please turn to channel
10-7	Out of service, leaving air	10-42	Traffic accident at
10-8	In service, subject to call	10-43	Traffic Tie up at
10-9	Repeat message	10-44	I have a message for you
10-10	Transmission completed, standing by	10-45	All units within range please report
10-11	Talking too rapidly	10-50	Break channel
10-12	Visitors present	10-60	What is next message number?
10-13	Advise Weather/Road conditions	10-62	Unable to copy, use phone
10-16	Make pick up at	10-63	Net directed to
10-17	Urgent business	10-64	Net clear
10-18	Anything for us?	10-65	Awaiting your next message/assignment
10-19	Nothing for you, return to base	10-67	All units comply
10-20	My location is	10-70	Fire at
10-21	Call by telephone	10-71	Proceed with transmission in sequence
10-22	Report in person to	10-77	Negative contact
10-23	Stand by	10-81	Reserve hotel room for
10-24	Completed last assignment	10-82	Reserve room for
10-25	Can you contact	10-84	My telephone number is
10-26	Disregard last information	10-85	My address is
10-27	I am moving to channel	10-91	Talk closer to microphone
10-28	Identify your station	10-93	Check my frequency on this channel
10-29	Time is up for contact	10-94	Please give me a long count
10-30	Does not conform to FCC rules	10-99	Mission completed, all units secure
10-32	I will give you a radio check	10-200	Police needed at
10-33	EMERGENCY TRAFFIC		
10-34	Trouble at this station		

Care and Maintenance

The **GRANT XL** is designed to give you years of trouble-free service. There are no user-serviceable parts inside, and except for the fuse in the DC power cord, no maintenance is required.

Note: *Do not expose the unit to moisture. Rain, dew, or other liquids may damage the internal components.*

Replacing the Fuse in the DC Power Cord

The main power lead (RED wire) on the DC power cord contains a 4-ampere, 3AG fuse in its holder.

To inspect or replace a blown fuse:

1. Press the ends of the fuse holder together and twist counterclockwise. Carefully separate the two halves.
2. Remove the fuse and inspect. If blown, replace with the *same* type.

Important: *Using any fuse other than the one specified for your **GRANT XL** may void the warranty.*

3. Replace the fuse inside the fuse holder, and reassemble the two halves by pressing the ends together and twisting clockwise.

Servicing Your CB

Technical information, diagrams, and charts are available upon request. It is the user's responsibility to see that this radio is operating at all times in accordance with the FCC Citizens Band Radio Service regulations. We highly recommend that you consult a qualified radiotelephone technician for service and alignment of this radio.

When ordering parts, please specify the correct model number and serial number of this radio.

Please refer to the "WARNING" information on page 1 of this manual.

Troubleshooting

Problem	Suggestion
Unit does not power on.	<ul style="list-style-type: none"> • Check the ignition key position. • Check all connections to the DC power cord as well as the fuse inside the holder. If fuse is out, replace with a 4-ampere, 3AG fuse only. • Check the vehicle electrical system.
No reception.	<ul style="list-style-type: none"> • Make sure the microphone is properly connected. • Set the CB/PA Switch to CB. • Adjust the squelch and volume. • Make sure that the antenna and its connections are not broken. • Set the RF Gain Control to the full clockwise position.
Poor reception.	<ul style="list-style-type: none"> • Adjust the squelch and volume. • Check to see that the antenna SWR is 2 or below. • Set the RF Gain Control to the full clockwise position. • Check the Mode Selector setting. If an SSB signal is being received, switch to the proper mode setting (USB or LSB). • Adjust the Clarifier Control.
No transmission.	<ul style="list-style-type: none"> • Set the CB/PA Switch to CB. • Make sure that the microphone is properly connected. • Set the Microphone Gain Control to the full clockwise position.
Low transmission.	<ul style="list-style-type: none"> • Check to see that the antenna SWR is 2 or below. • Set the Microphone Gain Control to the full clockwise position.

If you cannot get satisfactory results with your **GRANT XL**, please call the Uniden Customer Service Center at 1-317-842-2483, 8:00 A.M. to 5:00 P.M. EST, Monday through Friday. If service is necessary, contact your local Uniden dealer or return the product in its original carton. If you are shipping the item, enclose a description of the problem along with a copy of the original purchase receipt. Send the product to the address listed in the Warranty (at the end of this manual).

Specifications

General

Channels:	40 AM, 40 LSB, 40 USB
Frequency Range:	26.965 to 27.405 MHz
Frequency Control:	Phase Locked Loop (PLL) synthesizer
Frequency Tolerance:	0.005%
Frequency Stability:	0.001%
Operating Temperature:	-30° C to +50° C
Microphone:	Plug-in dynamic with PTT (push-to-talk) switch and coiled cord
Input Voltage:	13.8 VDC nominal, 15.9V max, 11.7V min. (positive or negative ground)
Current Drain:	TX: AM full modulation, 2.2A SSB 12 watts, PEP output, 2A RX: Squelched, 0.25A; with maximum audio output, 0.6A
Size:	7-7/8" (W) x 9-1/4" (D) x 2-3/8" (H)
Weight:	4 lbs. 14 oz. with microphone
Antenna Connector:	UHF, SO-239
Semiconductors:	3 field effect transistors, 45 transistors, 63 diodes, 6 integrated circuits, 1 two-color LED
Meter (3-in-1)	Illuminated; indicates relative power output, received signal strength, and SWR

Transmitter

Power Output:	AM, 4 watts SSB, 12 watts, PEP
Modulation:	High- and low-level, Class B amplitude modulation
Intermodulation Distortion:	SSB: 3rd order, more than -25 dB 5th order, more than -35 dB
SSB Carrier Suppression:	55 dB
Unwanted Sideband	50 dB
Frequency Response:	AM and SSB; 300 to 2500 Hz
Output Impedance:	50Ω, unbalanced
Output Indicators:	Meter shows relative RF output power and SWR Transmit LED glows red when transmitting

Receiver

Sensitivity:	SSB: 0.25 μ V for 10 dB; (S+N)/N at greater than 1/2-watt of audio output AM: 0.5 μ V for 10 dB; (S+N)/N at greater than 1/2-watt of audio output
Selectivity:	AM: 6 dB @ 3 kHz, 50 dB @ 9 kHz SSB: 6 dB @ 1.1 kHz, 60 dB @ 2.3 kHz
Image Rejection:	More than 65 dB
Adjacent-Ch. Rejection:	60 dB AM; 70 dB SSB
IF Frequency:	AM: 7.8 MHz 1st IF, 455 kHz 2nd IF SSB: 7.8 MHz
Automatic Gain Control (AGC):	Less than 10 dB change in audio output for inputs from 10 to 100,000 μ V
Squelch:	Adjustable; threshold less than 0.25 μ V
AM and SSB RF Gain Control:	40 dB adjustable for AM and SSB
Clarifier Range:	\pm 1.5 kHz
Noise Blanker:	RF type, effective on AM and SSB
ANL:	Switchable
Audio Output Power:	4 watts into 8 Ω
Frequency Response:	300 to 2500 Hz
Internal Speaker:	8 Ω , round
External Speaker (not supplied):	8 Ω ; disables internal speaker when connected
PA System	
Power Output:	4 watts into external speaker
External Speaker for PA (not supplied):	8 Ω

Specifications shown are typical and subject to change without notice.

Two Year Limited Warranty

WARRANTOR: UNIDEN AMERICA CORPORATION ("Uniden")

ELEMENTS OF WARRANTY: Uniden warrants, for two years, to the original retail owner, this Uniden Product to be free from defects in materials and craftsmanship with only the limitations or exclusions set out below.

WARRANTY DURATION: This warranty to the original user shall terminate and be of no further effect 24 months after the date of original retail sale. The warranty is invalid if the Product is (A) damaged or not maintained as reasonable or necessary, (B) modified, altered, or used as part of any conversion kits, subassemblies, or any configurations not sold by Uniden, (C) improperly installed, (D) repaired by someone other than an authorized service center for a defect or malfunction covered by this warranty, (E) used in any conjunction with equipment or parts or as part of any system not manufactured by Uniden, or (F) installed, programmed, or serviced by anyone other than an authorized Uniden service center.

STATEMENT OF REMEDY: In the event that the product does not conform to this warranty at any time while this warranty is in effect, warrantor will repair the defect and return it to you without charge for parts, service, or any other cost (except shipping and handling) incurred by warrantor or its representatives in connection with the performance of this warranty. THE LIMITED WARRANTY SET FORTH ABOVE IS THE SOLE AND ENTIRE WARRANTY PERTAINING TO THE PRODUCT AND IS IN LIEU OF AND EXCLUDES ALL OTHER WARRANTIES OF ANY NATURE WHATSOEVER, WHETHER EXPRESS, IMPLIED OR ARISING BY OPERATION OF LAW, INCLUDING, BUT NOT LIMITED TO ANY IMPLIED WARRANTIES OF MERCHANT ABILITY OR FITNESS FOR A PARTICULAR PURPOSE. THIS WARRANTY DOES NOT COVER OR PROVIDE FOR THE REIMBURSEMENT OR PAYMENT OF INCIDENTAL OR CONSEQUENTIAL DAMAGES. Some states do not allow this exclusion or limitation of incidental or consequential damages so the above limitation or exclusion may not apply to you.

LEGAL REMEDIES: This warranty gives you specific legal rights, and you may also have other rights which vary from state to state. This warranty is void outside the United States of America.

PROCEDURE FOR OBTAINING PERFORMANCE OF WARRANTY: If, after following the instructions in this Operating Guide you are certain that the Product is defective, pack the Product carefully (preferably in its original packaging) and include a note describing the defect that has caused you to return it. The Product should be shipped or delivered (by UPS or insured parcel post), freight prepaid to warrantor at:

**Uniden America Corporation
Parts and Service Division
8707 North By Northeast Blvd.
P.O. Box 501368
Indianapolis, IN 46250
(317) 842-2483, 8 AM to 5 PM EST, Monday through Friday**

with evidence of original purchase.

uniden®

©1992 Uniden America Corporation. All rights reserved.

UTUD01512DA

Printed in the Philippines