



RCI-2995DX HP

AM/FM/SSB/CW

10 & 12 Meter

Amateur Base Station

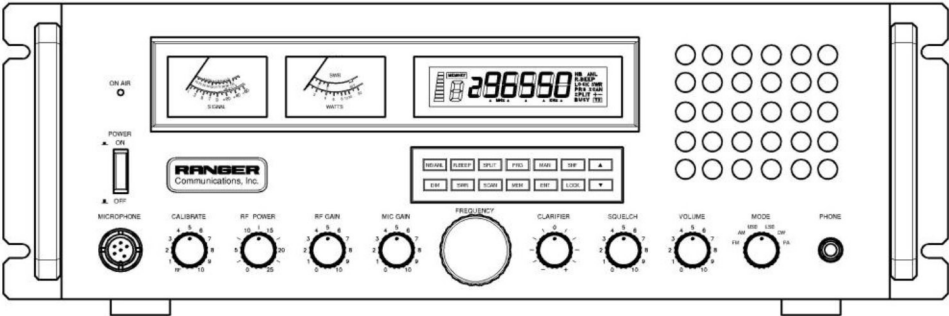

User's Manual

Table of Contents

	<u>PAGE</u>
Chapter 1 Specifications	3
Chapter 2 Introduction	5
Chapter 3 Installation	6
Location and Connection	6
Noise Interference	6
Antennas	6
Remote Speaker	7
Public Address	8
Chapter 4 Operation	9
Controls and Indicators	9
Front Panel	9
Programming Key Pad	12
Rear Panel Connectors	14
Microphone	16
Operating Procedure to Receiver	16
Operating Procedure to Transmit	16
Microphone Gain Control	18
Public Address Operation	18
SWR Measurement	19
Chapter 5 Programming	20
Frequency Selection	20
Receive Scanning	20
Split Function	21
Memory Function	21
Memory Scanning	22
Chapter 6 Frequency Scanning	23
All-Frequency Channel Scanning	23
Chapter 7 Offset Frequency Operation	24
LIMITED WARRANTY	Inside Back Cover

Chapter 1 Specifications

GENERAL

Model	RCI-2995 DX HP
Frequency Range : 12 meter	24.890 ~ 24.990 MHz
: 10 meter	28.000 ~ 29.699 MHz
Tuning Steps	100 Hz, 1 KHz, 10 KHz, 100 KHz, 1 MHz
Emission	USB, LSB, CW, AM, FM
Frequency Control	Dual Phase-lock-loop Synthesizer
Frequency Tolerance	0.005%
Frequency Stability	0.001%
Operating Temperature Range	-20°C to +50°C
Microphone	Plug-In (6-Pin), 400Ω Dynamic PTT
AC Input Voltage	100VAC ~ 120VAC (60Hz/50Hz)
AC Power Consumption	300W
Antenna Connectors	Standard SO-239 Type
Meter	Meter #1 : Indicates relative RF Power Output/Antenna SWR Meter #2 : Indicates Received Signal Strength/AM Modulation

TRANSMITTER

RF Power Output	80W RMS : CW/AM/FM 200W PEP : AM/USB/LSB
SSB Generation	Dual-Balanced Modulation
AM Modulation	Class B Amplitude Modulation
FM Deviation	±4KHz @ 1KHz 30mV Audio (±5KHz max.)
Clarifier Range	±5 KHz
Harmonic and Spurious Emission	Better than 60 dB
AM/FM Frequency Response	400 to 5000 Hz
SSB Frequency Response	400 to 3000 Hz
Output Impedance	50 Ohms Unbalanced
Output Indicators	RF Meter shows relative RF Output Power

NOTE

Amateur Radio License is required to operate this device. For licensing information within the United States of America, visit <http://www.fcc.gov>, for residence of Canada, visit <http://www.rac.ca>

Specifications (Continued)

RECEIVER

Sensitivity	AM/CW : 0.50uV for 10dB S+N/N FM : 0.25uV for 12dB S+N/N USB/LSB : 0.15uV for 10dB S+N/N
AM/FM Selectivity	50dB at 10 KHz
SSB Selectivity	60dB at 4 KHz
Image Rejection	More than 50dB
IF Rejection	More than 80dB
AGC	SSB/CW/AM 80 dB for 50mV for 10 dB Change in Audio Output
Squelch	Adjustable-Threshold less than 0.7 uV
Audio Frequency Response	400 to 2500 Hz
Distortion	Less than 10% at 2Watts Output into 8 Ohms
Adjacent Channel Rejection	>50 dB
Cross Modulation	>50 dB
Intermediate Frequency	10.695MHz (AM-1st, SSB), 455KHz (AM-2nd)
Clarifier Range	±5 KHz
Noise Blanker	IF Single Gate Type
Audio Output Power	More than 3 Watts into 8 Ohms
Built-in Speaker	8 Ohms
External Speaker (Optional)	Disables Internal Speaker when connected

(SPECIFICATIONS SUBJECT TO CHANGE WITHOUT NOTICE.)

Chapter 2 Introduction

Thank you for your confidence in selecting the RCI-2995DX HP Dual Band Amateur transceiver. We know you will find your transceiver as exciting as it is practical. Many years of valuable experience designing electronic products are behind our communications systems. Only the highest quality components are incorporated into our radios to assure reliability and maximum performance.

Installing and operating your transceiver is not complicated, but the flexibility provided by its numerous operating features may not be fully appreciated until a little time is spent becoming familiar with its controls and connections. It will be to your advantage to save all the packing materials cartons, fillers, cushioning, etc; they will prove valuable preventing damage should you ever have occasion to transport or ship your transceiver to your dealer.

Chapter 3 Installation

A) Location/Connection

The transceiver should be placed in a convenient operating location close to an AC power outlet and the antenna lead in cable(s).

The transceiver is attached with the AC power cord set. Proceed as follows to complete all necessary connections to the transceiver.

1. Your transceiver has a standard type SO-239 antenna connectors located on the rear panel for easy connection to standard PL-259 coax plugs. If the coax antenna cable must be made longer, use coax cable with impedance of 50 ohms and use only enough cable to suit your needs. This will insure a proper impedance match and maximum power transfer from the transmitter to the antenna.

2. **AC Power Operation:** 100~120 VAC (60Hz/50Hz) power input.

B) Noise Interference

There are several kinds of noise interference you may encounter in fixed operation. Some of these noise sources are; fluorescent buzz, nearby commercial broadcast, electrical appliance, lawnmower, and electrical storms, etc. Commercial products are available to reduce interference from these sources. Consult your dealer or professional amateur radio supply shops.

C) Antennas

For best transmission and reception, you should use an antenna especially cut for a frequency of 24.9 MHz and/or 28-30 MHz (12 & 10 meter bands). Antennas are purchased separately and include installation instructions. Numerous types of antennas are available in that range from simple verticals and dipoles to directional beams or quads, which provide gain and directivity. Often the difference in performance between antennas can make quite a difference in receiving and transmitting performance.

Installation (Continued)

1. **Vertical Ground Plane Antenna:** These omni-directional antennas can provide optimum performance for DX work due to their low angle of radiation.

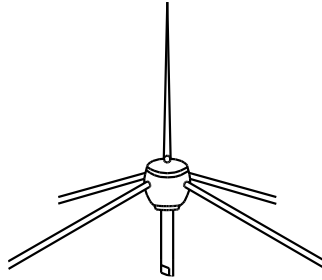

Ground Plane

2. **Directional Beam Antenna:** Concentrates power in a narrower beam thereby providing gain and directivity.

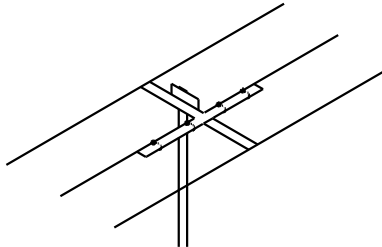

Directional Beam Antenna

D) Remote Speaker

The external speaker jack (EXT. SP.) on the rear panel is used for remote receiver monitoring. The external speaker should have 8 ohms impedance and be able to handle at least 3 watts. When the external speaker is plugged in, the internal speaker is disconnected.

Installation (Continued)

NOTE

The PHONE jack on the front panel overrides both external and internal speakers. When the plug from a headphone is plugged to the PHONE jack, both internal and external speakers are silenced simultaneously.

E) Public address

An external 8 Ohms, 4W speaker must be connected to the PA jack located on the rear panel when the transceiver is used as a public address system. The speaker should be directed away from the microphone to prevent acoustic feedback. Physical separation or isolation of the microphone and speaker is important when operating the PA at high output levels.

Chapter 4 Operation

A) Controls and Indicators

i) Front Panel

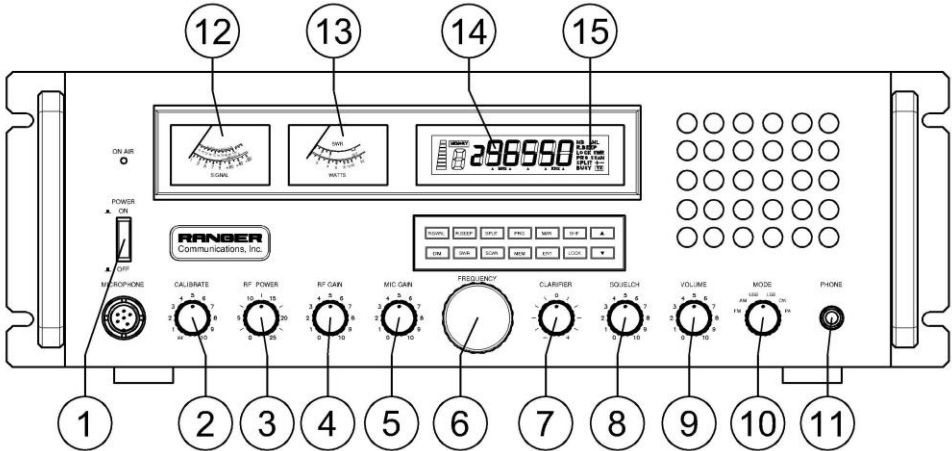

- 1. POWER ON/OFF CONTROL:** Push ON to apply power to the unit.
- 2. CALIBRATE CONTROL:** This control is used for calibrating the built in SWR meter for accurate SWR readout. Control should normally be left in the fully counter clockwise position for accurate power output meter readings. (This stop is marked "RF")
- 3. RF POWER CONTROL:** This control adjusts the RF power output level.
- 4. RF GAIN:** This control is used primarily to improve reception in strong signal areas. Under normal operating conditions, the control should be turned fully clockwise. When strong overloading or distorted signals are received, rotate this control counterclockwise to reduce gain.
- 5. MICROPHONE GAIN:** Experiment with this control for the setting that will provide you with best transmit audio quality. Avoid over modulation, which causes interference and "splatter".

Operation (Continued)

6. **FREQUENCY SELECTOR:** Used to select the desired operating frequency. The frequency is digitally displayed in the window above the selector.
7. **CLARIFIER CONTROL:** Allows variation of the receiver operating frequencies above and below the selected frequency. Although this control is intended primarily to tune in SSB signals when communicating with several stations which may not all be exactly on the same frequency, it may also be used to optimize AM or FM signals as described in the operating procedure paragraph.
8. **SQUELCH CONTROL:** This control is used to cut off or eliminate receiver background noise in the absence of incoming signal. For maximum receiver sensitivity, the control should be adjusted only to the point where the receiver background noise or ambient background noise is just eliminated. Turn fully counterclockwise then slowly clockwise until the receiver noise disappears. Any signal to be received must now be slightly stronger than the average received noise. Further clockwise rotation will increase the threshold level that a signal must overcome in order to be heard. Only strong signals will be heard at a maximum clockwise setting.
9. **VOLUME CONTROL:** Adjusts the audio listening level when receiving.
10. **MODE SELECTOR:** Selects the mode of operation to PA, CW, or standard AM, FM, USB or LSB.
11. **PHONE JACK:** Accepts a plug from a headset of 4 to 32 Ohm impedance. Insertion of the plug will disable the built in speaker including any external speaker connected to External Speaker jack.

NOTE

The Squelch Control may require readjustment with reduced RF Gain control.

Operation (Continued)

12. **RF/SWR METER:** Used for two purposes - to indicate approximate transmitter power when transmitting and antenna SWR (standing wave ratio). Note that the power meter has separate scales for AM, FM, SSB and CW transmission, respectively.
13. **SIGNAL/MODULATION METER:** This meter indicates signal strength when receiving and modulation percentage when transmitting in the AM mode. Modulation readings are most accurate when using maximum output power. The modulation meter does not show movement in FM or SSB, but the Power Output meter (RF/SWR) does indicate RF out in these modes.
14. **FREQUENCY DISPLAY:** The frequency display indicates the operating frequency.
15. **FUNCTION INDICATORS:** The indicators allow you to know instantly the selected operating mode.

Operation (Continued)

ii) Programming Key Pad

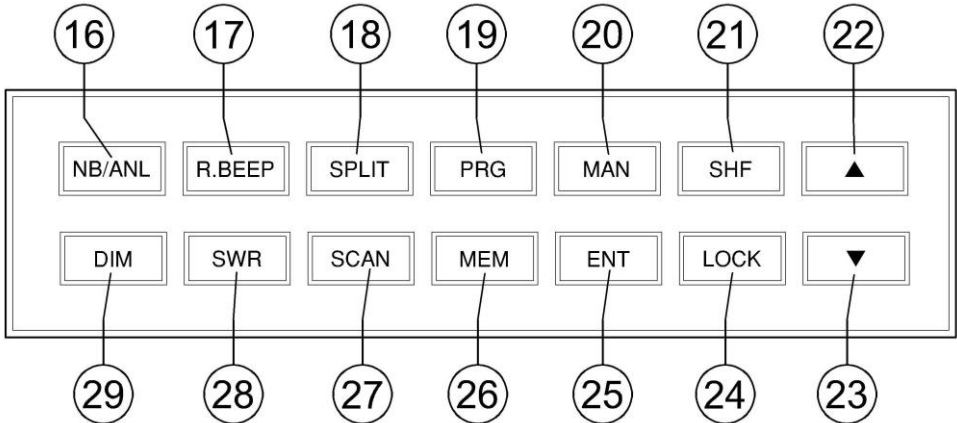

16. **NB/ANL SWITCH:** The Noise Blanker is very effective in eliminating repetitive impulse noise such as ignition interference. In the ANL position, the automatic noise limiter in the audio circuits is activated.
17. **ROGER BEEP SWITCH:** This switch activates the ROGER BEEP circuit, when its function is selected. When enabled, the radio automatically transmits an audio tone each time you release the PTT. This indicates the end of each transmission so that stations who may be having trouble hearing you will know that you have finished speaking. This feature is sometimes used in weak signal conditions or other special circumstances. We discourage use of this feature in normal operation, as it can be annoying to other operators.
18. **SPLIT SWITCH:** This switch enables offsetting the transmitter frequency from the receiver frequency for FM repeater operation.
19. **PROGRAM SWITCH:** This switch is used to program favorite frequencies into selectable memory locations, scanning limit frequencies or TX offset (repeater) split. See the OPERATION section for details.
20. **MANUAL SWITCH:** This is used to return to the manual mode.

Operation (Continued)

21. **SHIFT SWITCH:** This is used to select 100Hz, 1KHz, 10KHz, 100KHz or 1MHz frequency steps by moving the cursor under the appropriate digit on the LCD display.
22. & 23. **▲UP/▼ DOWN SELECTOR:** These buttons are used to move the frequency digit selected in step 21 (above), up or down.
24. **LOCK SWITCH:** This switch is used to lock a selected frequency. Press it to disable the **FREQUENCY** Selector Control, UP/DOWN buttons on the front control panel, and remote UP/DOWN buttons on the microphone. Pressing it again will unlock the frequency controls.
25. **ENTER SWITCH:** This is used to program frequencies in memory. See the PROGRAMMING section for more information on using this control.
26. **MEMORY SWITCH:** This is used to program frequencies into the memory. Detailed information on how to use this control is provided in the PROGRAMMING section.
27. **SCAN SWITCH:** This switch is used to scan frequencies in each band segment. The PROGRAMMING section provides detailed information on using this scan control.
28. **SWR SWITCH:** This switch is used to check antenna SWR.
29. **DIM SWITCH:** This switch adjusts the display backlighting in four different steps to best match lighting conditions.

Operation (Continued)

iii) Rear Panel Connectors

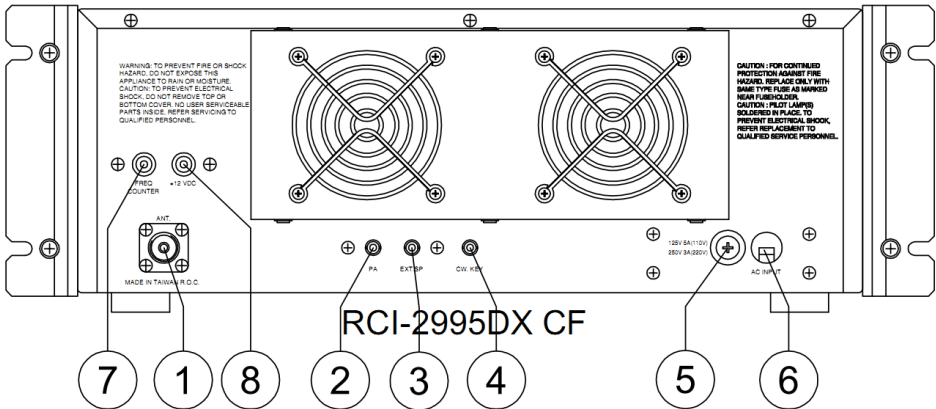

1. **ANTENNA:** This jack accepts 50 Ohm coaxial cable with a type PL-259 connector.
2. **PA SPEAKER JACK:** This jack is for public address operation. Before operating in the PA mode, you must first connect a PA speaker (8 Ohms, 4W, 1/8" or 3.5mm diameter plug) to this jack.
3. **EXTERNAL SPEAKER JACK:** This jack accepts a 4 to 8 Ohms, 4W external speaker. Use 1/8" (3.5mm) diameter plug for connection. When an external speaker is connected to this jack, the built-in speaker is disabled.
4. **CW KEY:** Used for Morse code operation. Connect a CW key to this jack and set the **MODE SELECTOR** switch to the CW position.
5. **FUSE:** Accommodates a fuse for AC input circuit protection. Use 125V/5A fuse for 110 VAC operation.

NOTE

Before replacing the fuse, see your dealer to check and find out the reason why the fuse was blown. Replacing without checking the cause may only blow the fuse again.

Operation (Continued)

6. **AC POWER CORD:** Connects to AC power outlet.
7. **FREQUENCY COUNTER OUTPUT JACK:** This RCA type jack provides output for connecting an optional frequency counter to read the transmit frequency on an external frequency counter. The external frequency counter will only display the transmit frequency.
8. **+12 VDC:** This “RCA Phono” type jack provides 12 VDC power for an optional external cooling fan.

Operation (Continued)

B) Microphone

The receiver and transmitter are controlled by the push-to-talk switch on the microphone. Press the switch and the transmitter is activated, release switch to receive. When transmitting hold the microphone two inches from the mouth and speak clearly in a normal “voice”. This transceiver comes complete with a low-impedance dynamic microphone.

For best results, the user should select a low-impedance dynamic type microphone or a transistorized microphone.

The microphone should provide the functions shown in schematic below.

6 WIRE MIC CABLE

<u>Pin Number</u>	<u>Mic Cable Lead</u>
1	Audio Shield
2	Audio Lead
3	Transmit Control
4	Receive Control
5	Up Control
6	Down Control

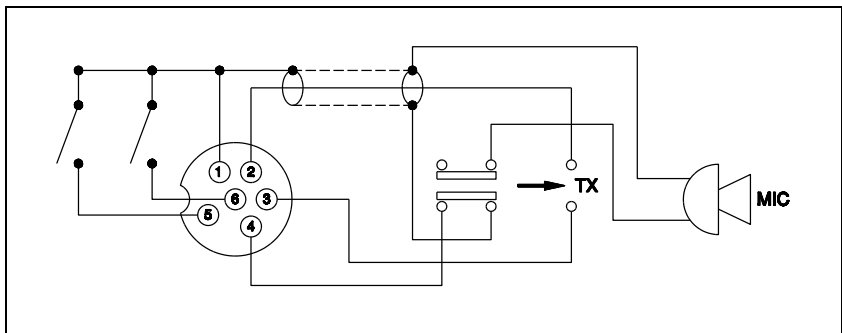

Microphone Schematic Diagram

Operation (Continued)

C) Operating Procedure (Receive Mode)

1. Turn the unit on by setting the POWER SWITCH to ON position. The meters, Frequency Indicator, and Function Indicators will illuminate.
2. Set the MODE SELECTOR switch to desired mode.
3. Set the SQUELCH CONTROL in fully counterclockwise position and adjust the VOLUME control for a comfortable listening level.
4. Set the CLARIFIER to the center (12 o'clock) position.

IMPORTANT:

Make sure that the ANTENNA and MICROPHONE are connected before you operate.

D) Operating Procedure To Transmit

1. Select the desired operating frequency.
2. If the frequency is clear, depress the Push-to-Talk switch on the microphone. Speak in a normal tone of voice.

Operation (Continued)

E) Microphone Gain Control

Start at the 12 o'clock position. Experiment with the control for a setting that provides best transmit audio as reported by other stations. Turning the Mic Gain up too high will cause unnecessary transmit audio distortion, splatter and interference to stations on adjacent frequencies.

F) Public Address Operation

To use this feature, a speaker having a voice coil impedance of 8 to 16 Ohms and a power handling capability of at least 3 Watts should be connected to the PA SP jack on the rear panel. Be sure that there is physical separation between the microphone and the PA speaker itself. If the PA speaker is located very close to the microphone, acoustic feedback will result when the PA amplifier is operated at high volume (or when PA is used indoors). Adjustment of PA volume is made with MIC GAIN control.

Operation (Continued)

G) SWR Measurement

This feature is necessary for proper antenna tuning. A properly cut antenna provides the proper impedance match to the transceiver. A well-matched antenna, as evidenced by low SWR, increases your output power and allows the final amplifier to run cooler and last longer. To measure your antenna's SWR:

1. Turn the unit ON.
2. Set the Mode switch to AM position.
3. Set the MIC GAIN CONTROL to minimum.
4. Set the RF POWER CONTROL to maximum.
5. Ensure frequency is clear.
6. Press the Push-to-Talk switch on the microphone and turn the Calibrate Control clockwise (out of detent position) so that the SWR meter pointer exactly coincides with the set mark on the scale. Release the Push-to-Talk switch.
7. Activate the SWR button. Press the Push-to-Talk switch again. The SWR of your antenna is read directly on the scale.

NOTE

An SWR below 2 or less is desired as this indicates that over 95% of the applied power is being radiated into the air and not dissipated as heat.

Chapter 5 Programming

A) Frequency Selection

Frequency selection in the RCI-2995DX HP can be accomplished by using any one of the three methods below:

1. The first method of frequency selection uses the **SHF** (Shift) key and the ▲ (UP)/▼ (DOWN) keys. To accomplish this, press the **SHF** key until the display cursor is positioned under the digit of the frequency that is to be changed. Then use the “▲” key to increase the number. If a decrease in frequency is desired, press the “▼” key. Perform the steps described above for each digit until the desired frequency is displayed in the **LCD** frequency display window.
2. The second method of frequency selection is performed using the **SHF** key and the frequency select knob located on the front panel. Use the **SHF** key in the manner described above to select the digit to be changed. Then rotate the **FREQUENCY** selector clockwise to increase the frequency and counter-clockwise to decrease the frequency.
3. The third method of frequency selection is using the **SHF** key and the frequency **UP** and **DOWN** button located on the microphone. Frequency selection by this method is accomplished in the same manner as with the “▲” key and the “▼” key on the keypad. The only difference is that the **UP** and **DOWN** buttons on the microphone is used.

Occasionally, when receiving more than one station on a fixed frequency such as on a “Net” or “round table” discussion, it may be handy to slightly vary the **receive** frequency without changing the transmit frequency. This is done while a station transmits to compensate for them being slightly off frequency. This is accomplished by rotating the clarifier control, (which varies the receiver frequency by ± 0.5 KHz) for clearest voice reception. The clarifier can be optionally modified to vary both Transmit and receive frequencies together.

B) Receive Scanning

The receive scanning feature allows you to locate active frequencies in the entire band segment. To begin scanning, slowly turn the **SQUELCH** control clockwise until the receiver noise disappears. Next, press the **SCAN** Key. The

Programming (Continued)

unit should start scanning from the lower to the higher frequencies. Pressing the **SCAN** key again will change the direction of scanning. When the **SCAN** key is pressed, "**SCAN+**" or "**SCAN-**" will be displayed on the LCD display. The scan will stop on any active frequency for the duration of the transmission. When the transmission stops, the unit will wait approximately 2 seconds before it resumes scanning. If you want to deactivate Scan mode while it is scanning, press the **MAN** (manual) key or turn the **SQUELCH** control counterclockwise until you hear the receiver noise. The **MAN** key will disable the Scan function. (See **Frequency Scanning**, page 22 for more information.)

C) Split Function

This function enables you to split the transmit and receive frequencies for FM repeater operation. To split frequencies, press the **MAN** key and the **SPLIT** key to select + split frequency. If you want - split frequency, press the **SPLIT** key again. If + split is selected, the transmit frequency will be higher than the receiver frequency. If - split is selected, it will be lower than the receive frequency. (See **Offset Frequency Operation**, page. 24 for more information.)

D) Memory Function

The transceiver can store up to 16 frequencies in memory locations zero to F. To program a frequency into memory, follow the procedure described below:

1. Set the desired frequency you wish to store in memory.
2. Press the **PRG** key.
3. Press the **MEM** key.
("MEMORY" and "0" should appear on the left hand side of the LCD display). Pressing the **MEM** key will increase the memory counter to the next memory location.
4. Press the **ENT** key.
5. To program other memory channels, press **MAN** key and repeat step 1 thru 4

NOTE

If all memory channels are programmed, the display will show "FULL"

Programming (Continued)

To clear a memory channel or to erase all programmed frequencies, follow the procedures below:

1. To clear a particular memory location, locate the memory channel you wish to clear by pressing the **MEM** key. Once you have located the memory channel you wish to clear, press and hold **PRG** key for about four seconds or until “ErASE” is displayed, selected memory channel is now cleared of its frequency.
2. To clear all memory channels (including scan limits and split frequencies), press **MEM** key and then press and hold **ENT** key for about 10 seconds, “CLEAR” will appear first on the display followed by “ErASE”. Release the **ENT** key, memory is now cleared of all programmed frequencies.

E) Memory Scanning

Your transceiver has 16 non-volatile (i.e., memory resident) locations that can be programmed with any available frequency within the operating band of the radio. The scan function of the unit can be also programmed to scan these memory locations. In this mode, the radio will scan only frequencies that have been pre-programmed in memory.

The first step in utilizing the memory scan function is to program (refer to the **Memory Function** section) the desired frequencies into the memory locations zero through F.

1. After the desired memory locations have been programmed with frequencies, return the unit to the manual mode of operation by pressing the **MAN** key.
2. To initiate memory scanning, press **MEM** and then **SCAN**. The display will show “**SCAN+**” or “**SCAN-**” to indicate whether the radio is scanning from the lowest to the highest memory location or vice versa. To return the radio to normal (non-scanning) operation, press the **MAN** key twice.

Chapter 6 Frequency Scanning

Frequency scanning can be achieved using one of two methods: the first method involves scanning of pre-programmed memory frequencies; the second method permits the user to scan all frequencies between a pre-set lower and upper scan limit. Both methods of frequency scanning follow.

All-Frequency Channel Scanning

To allow All-Frequency scanning, the user must first program the upper and lower scanning limits. The scan limits are simply the highest and lowest frequencies that will be scanned. To program these limits:

1. Press the **PRG** (Program) key.
2. Press the **SCAN** key. **PRG SCAN+** should appear in the lower right-hand corner of the display window.
3. Using the **SHF** key and “▲” and “▼” keys (or frequency selector knob), set the upper scan limit.
4. Press the **SCAN** key again. **SCAN-** should appear in the display window.
5. Using the **SHF** key and “▲” and “▼” keys (or frequency selector knob), set the lower scan limit, and then press **ENT**.

The upper and lower scan limits have now been programmed. To activate the scan feature, return the radio to manual operation and press the **SCAN** key. If the display shows "**SCAN+**", the radio will scan from the lower limit to the upper limit. If "**SCAN-**" is displayed, the unit will scan from the upper limit to the lower limit. To change from "**SCAN+**" to "**SCAN-**" or vice versa, press **SCAN**.

CAUTION

Whichever upper and lower scan limits are programmed in, are also the upper and lower operating limits of the radio. The radio will not operate above or below the scan limits last programmed in. Full band coverage can be returned by reprogramming the original band limits.

Chapter 7 Offset Frequency Operation

The RCI-2995DX HP has an offset or split-frequency feature that permits the radio to be operated in a half-duplex mode. This allows the user to talk on FM repeaters operating in the 10 meter and 12 meter band. (**NOTE:** *FM repeaters may require that a sub-audible (CTCSS) tone be transmitted to gain access to the repeater. The RCI-2995DX HP are not factory-equipped with a CTCSS encoder/decoder, however that option can be added*). The split frequency function offsets the transmitter frequency either above or below the receiver frequency by a user-programmable amount. In the following example, the programming of a 100 KHz offset will be described. Before attempting the program the offset frequency, ensure that the radio is operating in the manual mode by pressing the **MAN** key.

1. Press the **PRG** (Program) key.
2. Press the **SPLIT** key. The LCD display window will display "**00000**" with "**PRG**" and "**SPLIT**" being displayed in the lower left-hand corner.
3. Using the **SHF** key and "**▲**" and "**▼**" keys as described earlier, program the display to read "**01000**".
4. Press **ENT**. A 100 KHz offset has now been programmed into the radio.
5. Return the radio to manual operation by pressing the **MAN** key.
6. Using the **SHF** key and "**▲**" and "**▼**" keys as described previously, set the radio for the desired receive frequency.
7. Press **SPLIT**. In the lower right corner of the display, either "**SPLIT+**" or "**SPLIT-**" will be displayed. If "**SPLIT+**" is displayed, the transmitter will be offset 100 KHz above the receive frequency when keyed. If "**SPLIT-**" is displayed, the transmitter will be offset 100 KHz below the receive frequency.

NOTE

When the transmitter is keyed, the frequency display will change to show the frequency being transmitted.

Ranger Communications Limited Warranty

Ranger Communication, Inc. (Ranger) warrants to the original purchaser only this product against defects in material or workmanship, as noted below.

Effective December 1, 2001, Ranger Communications, Inc.'s Amateur and CB radio products are covered by a two (2) year limited warranty:

The above products are warranted for the specified period from the original date of purchase as shown on the original purchaser's bill of sale, receipted invoice, or other proof of purchase. After this period, the original purchaser must pay for any labor at the prevailing rate either at an authorized Ranger warranty repair facility or at the factory.

In the event of a defect during the warranty period, Ranger shall, at its option, repair or replace the defective product. Such action shall constitute the purchaser's exclusive remedy under this warranty.

A Return Authorization Number must be obtained from the Ranger Customer Service Department before any returns for warranty repair will be accepted. Send the defective product postage-paid, along with proof of the date of purchase (photocopy of the original invoice or receipt). Please contact RCI for Return Authorization at:

Ranger Communications, Inc.
867 Bowsprit Road
Chula Vista, CA 91914
E-mail: sales@rangerusa.com

This warranty does not cover cosmetic damage or damage due to acts of God, accident, misuse, abuse, negligence, improper installation, UNAUTHORIZED MODIFICATION, or any action in violation of the product's instruction manual. This warranty is valid only in the U. S. A.

1. "Limited" means that we will repair problems that are caused by factory defects, only for the above-mentioned products and time limit, at no charge. Work performed by qualified technicians who did not cause any damage to the radio will not void the warranty. Problems or damage caused by unqualified or misinformed technicians, operator abuse or other miscellaneous actions may be able to be repaired, but there will be a charge. This warranty is limited to the radio only.

2. Generally, if the warranty sticker is removed or cut, the radio is considered "Void of Warranty". However, our policy is to be as lenient as we can, and to take this into consideration. We will usually repair the radio - under warranty - if no abuse or misuse is found. Radios that have parts removed cut or clipped; or the PCB has been damaged, will not be repaired under warranty.



**867 Bowsprit Road
Chula Vista, CA 91914
Email: sales@rangerusa.com
<http://www.rangerusa.com>**

PRINTED IN MALAYSIA
P;/N:ATTTURB04Q