

# **ALIGNMENT      PROCEDURE**

MODEL: 200GTL

REVISION: 1.2

DATE: 02/14/06

PREPARED BY: BURKE

Total Pages: 6 pages

## 200GTL ALIGNMENT INSTRUCTION

### 1 TEST CONDITION:

- 1.0. TEST TEMPERTAURE: 77 ±9 °F
- 1.1. STANDARD DC POWER: 13.8VDC
- 1.2. STANDARD AUDIO LOADING: 8 Ω
- 1.3. ANTENNA IMPEDANCE: 50 Ω
- 1.4. STANDARD REF. MODULATION: AM 30%  
FM 2.5KHz
- 1.5. PULSE GENERATOR: 1μS pulse @ 100mS and 1V peak-to-peak amplitude,  
with rise and fall time of less than 10nS.

### 1.6. TEST EQUIPMENT SETUP AS BELOW:

#### A. TX test equipment setup:

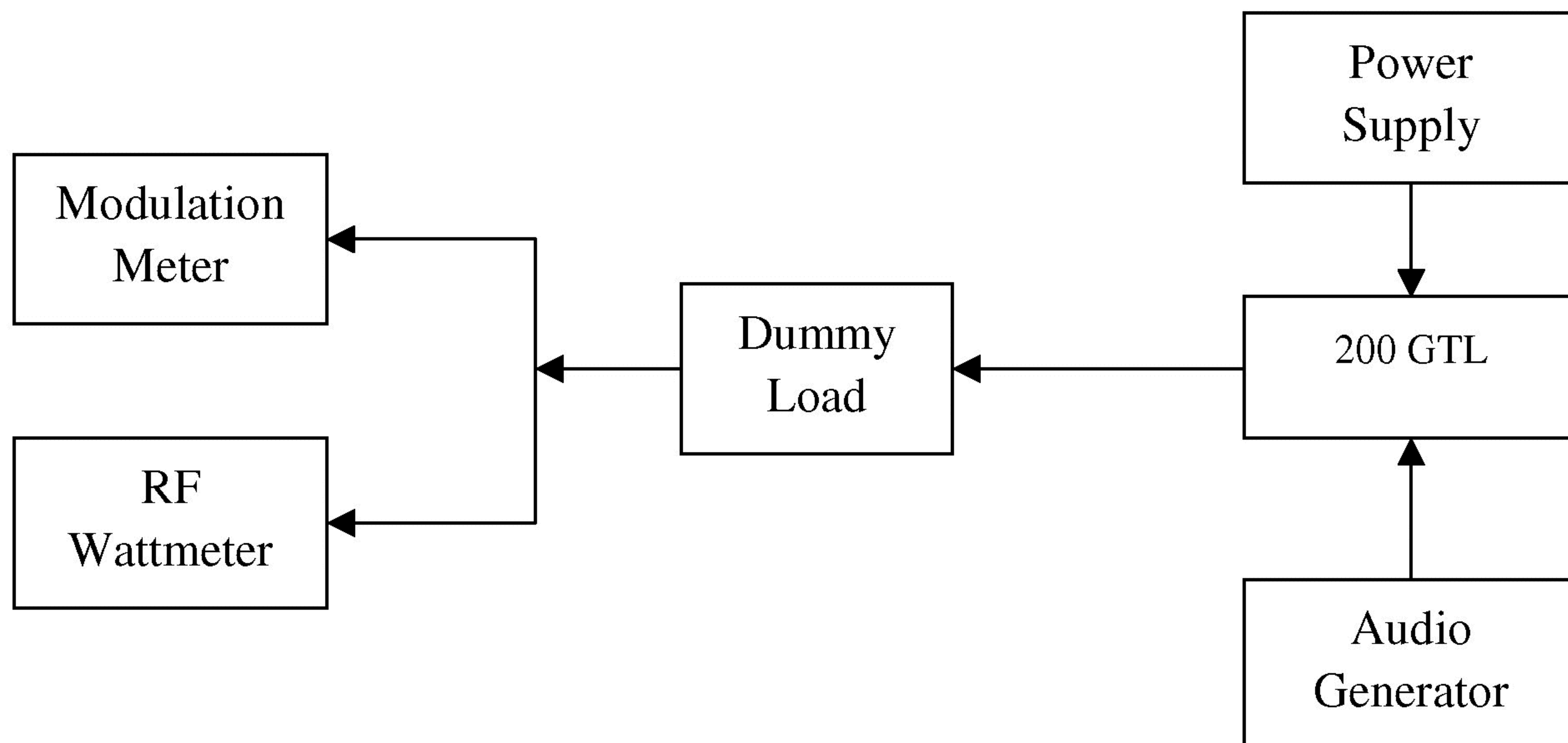

## B. RX test equipment setup:

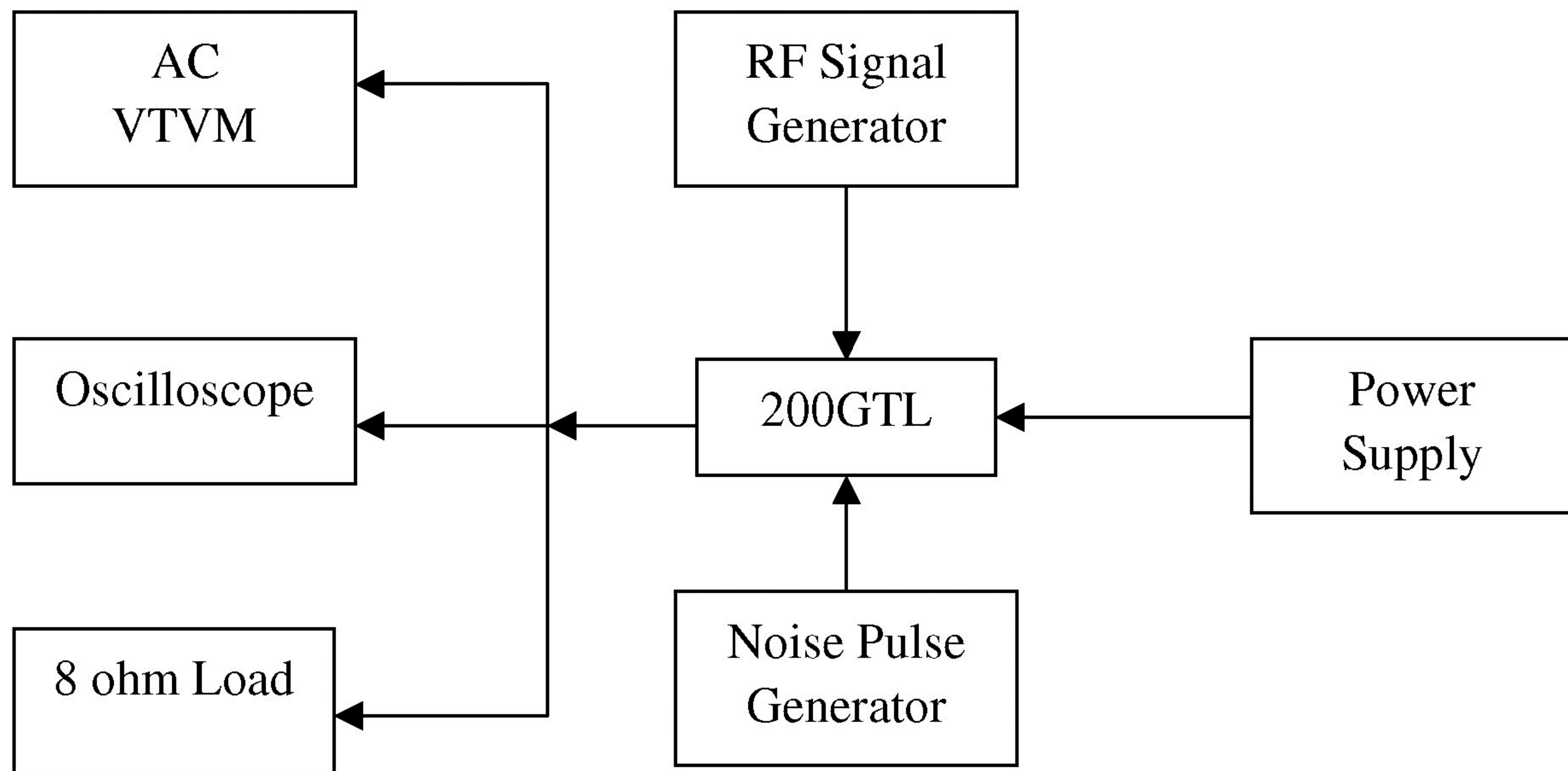
**2.0 MAIN ALIGNMENT**

## 2.1 PLL Alignment

STEP	PRESET TO	CONNECTIONS	ADJUST	PROCEDURE
1	RX mode, AM, 28.000MHz	Oscilloscope to TP1 (junction of R92-C607)	T712	Check for range of 0.2 to 7VDC, then set to 2.8V
2	Same as step 1	Oscilloscope to TP2 (forward end of BF9)	T713	Adjust for maximum output
3	Same as step 1	Frequency counter to TP2 (forward end of BF9)	T711	Adjust for 17.305MHz (frequency – 10.695)

## 2.2 Carrier Alignment

STEP	PRESET TO	CONNECTIONS	ADJUST	PROCEDURE
1	TX mode, AM, 28.000MHz	Frequency counter to TP3	T716	Adjust for 10.695MHz
2	RX mode, LSB, 28.000MHz	Same as step 1	T714	Adjust for 10.6975MHz
3	RX mode, USB, 28.000MHz	Same as step 1	T715	Adjust for 10.6925MHz



### 3.0 RECEIVER ALIGNMENT

Connect an AC VTVM with 8 ohm load across speaker coil.

Adjust volume control to obtain a suitable indication.

Set generator output low enough to prevent AGC limiting.

Preset controls as follows, unless otherwise noted:

**RF Gain** maximum, **Squelch** minimum, **NB/ANL** off.

STEP	PRESET TO	CONNECTIONS	ADJUST	PROCEDURE
1	RX mode, AM 28.000MHz	Output of signal generator to antenna connector. Freq. = 28.000MHz, 1KHz 30% modulation, RF output 1 $\mu$ V	T703, T704, T705, T706, T707, T708, T710	Adjust for maximum signal on VTVM
2	Same as step 1, squelch to maximum	Output of signal generator to antenna connector. Freq. = 28.000MHz, 1KHz 30% modulation, RF output 1500 $\mu$ V	RV2	SQUELCH RANGE Adjust just until squelch opens
3	RX mode, AM 29.500MHz (Band D)	Output of signal generator to antenna connector. Freq. = 29.500MHz, NO modulation, RF output 100 $\mu$ V	RV15	SIGNAL METER Adjust for a reading of S-9 on the analog meter of the radio
4	RX mode, AM, 28.000MHz, NB/ANL switch set to NB/ANL	Output of signal generator and noise pulse generator to antenna connector. Freq. = 28.000MHz, 1KHz 30% modulation, RF output 1 $\mu$ V. Oscilloscope to collector of Q6	T701	NOISE BLANKER Adjust for maximum amplitude on oscilloscope
5	RX mode, FM, 28.000MHz	Output of signal generator to antenna connector. Freq. = 28.000MHz, 2.5KHz deviation, RF output 1 $\mu$ V	T702	Adjust for maximum signal on VTVM



#### 4.0 TRANSMITTER ALIGNMENT

Maintain a 50 ohm 25 watt dummy load on the antenna connector for the following steps. Preset controls as follows, unless otherwise noted:

**RF Power** set to HI, **Mic Gain** to minimum.

STEP	PRESET TO	CONNECTIONS	ADJUST	PROCEDURE
1	TX mode, LSB, 29.700MHz	Insert a current meter between pins A(+) and B(-) of CON3	RV21	BIAS CURRENT Adjust for 1.3 amps
2	Same as step 1	Insert a current meter between pins C(+) and D(-) of CON3	RV19	BIAS CURRENT Adjust for 60mA
3	TX mode, AM, 29.700MHz	RF wattmeter to antenna connector	T718, T719, T720, T721, T722, T723, L21	Adjust for maximum RF output
4	TX mode, AM, 29.700MHz	RF wattmeter to antenna connector	RV9	RF POWER – HI Adjust for 32 watts
5	Same as step 4, Power switch to LO	Same as step 4	RV8	RF POWER - LO Adjust for 4 watts
6	TX mode, AM, 29.700MHz Power switch to HI		RV1	RF POWER METER Adjust for a reading of S-7 on the analog meter of the radio
7	TX mode, AM, 29.700MHz Mic Gain to maximum	Modulation meter to antenna connector. Insert a 1KHz, 30mV signal to microphone input.	RV12	AMC CONTROL - HI Adjust for 90% modulation
8	Same as step 7, Power switch to LO	Same as step 7	RV3	AMC CONTROL - LO Adjust for 90% modulation
9	TX mode, FM, 29.700MHz Mic Gain to maximum	Deviation meter to antenna connector. Insert a 1KHz, 30mV signal to microphone input.	RV5	DEVIATION LIMITER Adjust for 2.9KHz deviation
10	TX mode, LSB, 29.700MHz Mic Gain to maximum	RF wattmeter to antenna connector. Insert a 1KHz, 30mV signal to microphone input.	RV14	SSB POWER – HI Adjust for 100 watts
11	Same as step 10 Power switch to LO	Same as step 10	RV20	SSB POWER – LO Adjust for 12 watts
12	TX mode, LSB, 29.700MHz Mic Gain to minimum	Oscilloscope to antenna connector.	RV6	Adjust for minimum output

**TRANSMITTER ALIGNMENT** (continued)

STEP	PRESET TO	CONNECTIONS	ADJUST	PROCEDURE
13	TX mode, AM, Power switch to HI, Mic Gain to minimum, S/RF switch set to CAL	Connect a 100 ohm dummy load to the antenna connector	RV23	SWR METER Adjust SWR Cal knob so analog meter on radio goes to CAL mark. Then set S/RF switch to SWR and adjust RV23 for an SWR reading of 2 on the analog meter of the radio.
14	Same as step 13 Power switch to LO	Same as step 13	RV7	SWR METER Same as step 13 except adjust RV7 for a reading of 2 on the analog meter
15	TX mode, AM, Power switch to LO, Mic Gain to minimum	Short the antenna output to ground	RV4	ANTENNA LIGHT Adjust RV4 until the antenna light just comes on



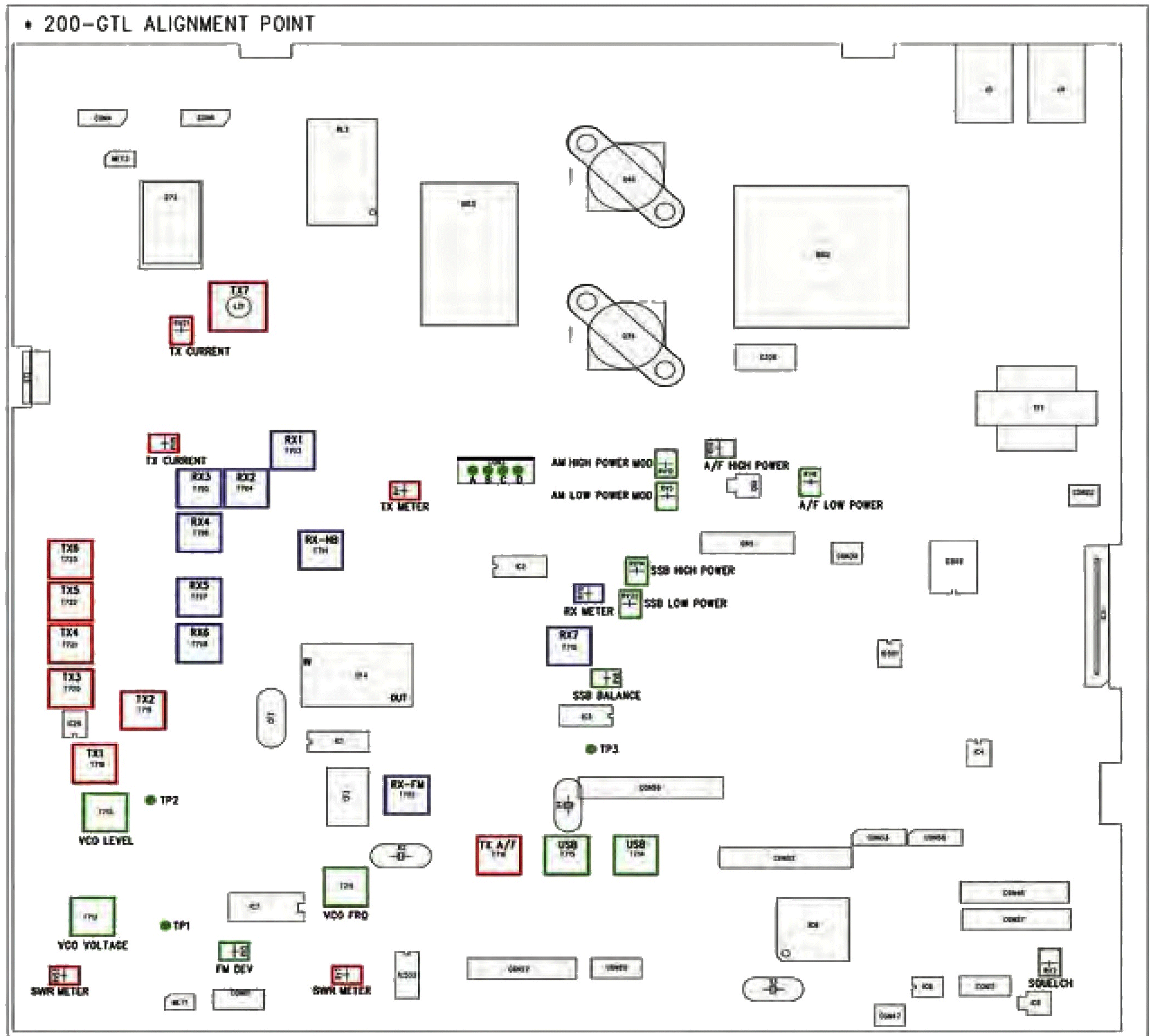



**REVISION HISTORY**

1.0 – Initial release.

1.1 – Corrected step 2 in section 2.2 (changed USB to LSB).  
Corrected step 3 in section 2.2 (changed LSB to USB).

1.2 – Added Step 15 in Section 4

# BLOCK DIAGRAM

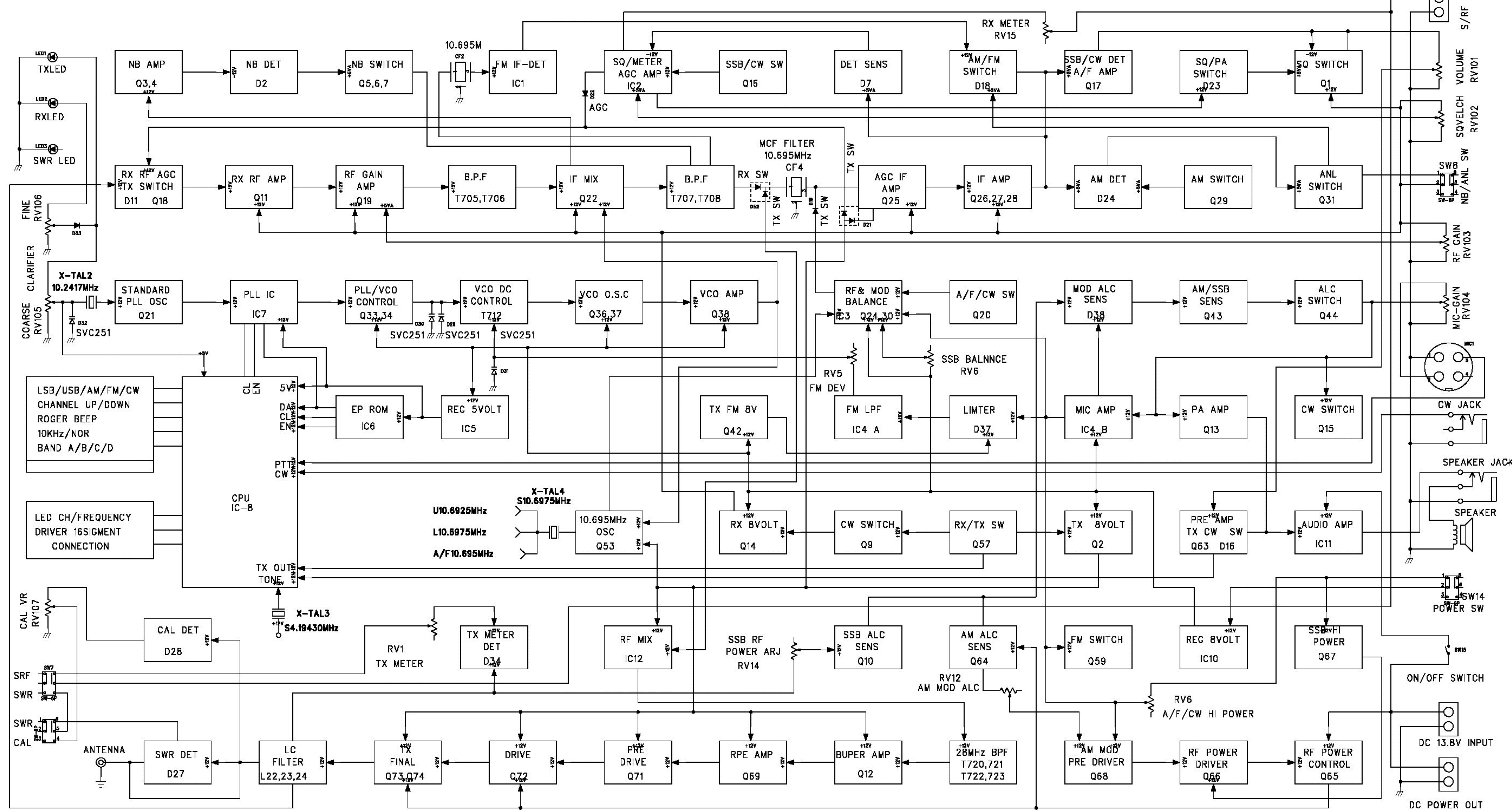

REV.	DATE	NAME	DESCRIPTION	CHECK
1	12/18/95			
2	10/26/95			

UNIT :	SCALS :	SHEET :	BUYER NAME :
DRW. :	CHK. :	APP. :	MODEL NAME :
K.A.JUNG 85/04/13			DRAWING NO. :



**TEST CONDITION:  
SUPPLY VOLTAGE: 13.8 V  
BAND A ( 28.000 MHz)**

<b>RX TESTING</b>							
<b>PIN NO.</b>	<b>SWITCH CONDITION</b>	<b>UNIT</b>	<b>CW</b>	<b>FM</b>	<b>AM</b>	<b>USB</b>	<b>LSB</b>
1		V	0	0	0	0	0
2		V	2.37	2.37	2.37	2.37	2.37
3		V	2	2	2	2	2
4		V	4.9	4.9	4.9	4.9	4.9
5			N.C.	N.C.	N.C.	N.C.	N.C.
6			N.C.	N.C.	N.C.	N.C.	N.C.
7		V	0	0	0	0	0
8			N.C.	N.C.	N.C.	N.C.	N.C.
9	DURING STANDBY	V	0	0	0	0	0
	WHEN CH. SW. TURN ON TO DOWN POSITION	V	4.7	4.7	4.7	4.7	4.7
10		V	4.9	4.9	4.9	4.9	4.9
11		V	0.44	0.44	0.44	0.44	0.44
12	DURING STANDBY	V	0	0	0	0	0
	DIM SWITCH FUNC. TURN ON	V	4.4	4.4	4.4	4.4	4.4
13		V	4.86	4.86	4.86	4.86	4.86
14		V	4.86	4.86	4.86	4.86	4.86
15		mV	13.6	13.6	13.6	13.6	13.6
16		mV	13.8	13.8	13.8	13.8	13.8
17			N.C.	N.C.	N.C.	N.C.	N.C.
18	DURING STANDBY	V	0	0	0	0	0
	WHEN CH. SW. TURN ON TO UP POSITION	V	4.7	4.7	4.7	4.7	4.7
19	STANDBY	V	0	0	0	0	0
	WHEN ROGER BEEP SWITCH TURN ON	V	4.7	4.7	4.7	4.7	4.7
20		mV	20.6	20.6	20.6	20.6	20.6
21		mV	17.6	17.6	17.6	17.6	17.61
22	DURING STANDBY	mV	3.1	3.1	3.1	3.1	3.1
	WHEN 10KHZ SWITCH TURN ON	V	4.7	4.7	4.7	4.7	4.7
23		V	4.9	4.9	4.9	4.9	4.9
24		mV	20.9	20.9	20.9	20.9	20.9
25		V	4.96	4.96	4.96	4.96	4.96
26		mV	45.6	45.6	45.6	45.6	45.6
27			N.C.	N.C.	N.C.	N.C.	N.C.
28	MODE SWITCH SET TO CW	V	6.8	0	0	0	0
29		V	4.96	4.96	4.96	4.96	4.96
30	BAND SWITCH SET TO A BAND / WHEN SET TO OTHER BAND PIN IS EQUAL TO ZERO VOLT	V	4.75	4.75	4.75	4.75	4.75
31	BAND SWITCH SET TO B BAND / WHEN SET TO OTHER BAND PIN IS EQUAL TO ZERO VOLT	V	4.75	4.75	4.75	4.75	4.75
32	BAND SWITCH SET TO C BAND / WHEN SET TO OTHER BAND PIN IS EQUAL TO ZERO VOLT	V	4.75	4.75	4.75	4.75	4.75
33	BAND SWITCH SET TO D BAND / WHEN SET TO OTHER BAND PIN IS EQUAL TO ZERO VOLT	V	4.75	4.75	4.75	4.75	4.75
34		V	0	0	0	0	0
35	NO CW JACK INSERTED	V	4.96	4.96	4.96	4.96	4.96
36	BOTH COARSE & FINE VR AT CENTER POSITION	V	2	2	2	2	2
	VR COARSE AT CENTER & FINE VR IN MINIMUM POSITION	V	1.8	1.8	1.8	1.8	1.8
	FINE VR AT CENTER & COARSE VR IN MINIMUM POSITION	V	0.65	0.65	0.65	0.65	0.65
	BOTH COARSE & FINE VR AT MINIMUM POSITION	V	0.62	0.62	0.62	0.62	0.62
	FINE VR AT CENTER & COARSE VR IN MAXIMUM POSITION	V	3.7	3.7	3.7	3.7	3.7
	COARSE VR AT CENTER & FINE VR IN MAXIMUM POSITION	V	2.3	2.3	2.3	2.3	2.3
	BOTH FINE & COARSE VR AT MAXIMUM POSITION	V	3.94	3.94	3.94	3.94	3.94
37			N.C.	N.C.	N.C.	N.C.	N.C.
38		mV	27.4	27.4	27.4	27.4	27.4
39		V	4.36	4.36	4.36	4.36	4.36
40		V	4.83	4.83	4.83	4.83	4.83
41	MODE SWITCH SET TO USB MODE	V	0	0	0	5.31	0
42	MODE SWITCH SET TO LSB MODE	V	0	0	0	0	5.4



PIN NO.	SWITCH CONDITION	UNIT	CW	FM	AM	USB	LSB
43	STANDBY	V	4.9	4.9	4.9	4.9	4.9
	CAL. FUNC. TURN ON	mV	43.4	43.4	43.4	43.4	43.4
44		mV	4.12	4.12	4.12	4.12	4.12
45		mV	114	114	114	114	114
46	DURING STANDBY	mV	53.1	53.1	53.1	53.1	53.1
	WHEN PRESSING DIM SW. FUNC. TO ONCE & 5 TIMES O	V	2	2	2	2	2
47		mV	113.9	113.9	113.9	113.9	113.9
48	DURING STANDBY	mV	53.1	53.1	53.1	53.1	53.1
	PRESSING DIM SW. FUNC. TO 2 & 4 TIMES ONLY	V	2	2	2	2	2
49		mV	114.6	114.6	114.6	114.6	114.6
50	DURING STANDBY	mV	53.1	53.1	53.1	53.1	53.1
	PRESSING DIM SW. FUNC. TO 3,4 & 5 TIMES ONLY	V	2	2	2	2	2
51		mV	113.9	113.9	113.9	113.9	113.9
52		mV	114.5	114.5	114.5	114.5	114.5
53		mV	112.5	112.5	112.5	112.5	112.5
54		mV	114	114	114	114	114
55		mV	114	114	114	114	114
56		mV	112	112	112	112	112
57		mV	111.7	111.7	111.7	111.7	111.7
58		mV	111.8	111.8	111.8	111.8	111.8
59		mV	108	108	108	108	108
60		mV	108	108	108	108	108

**NOTE: PIN 61 - 80 NO CONNECTION**

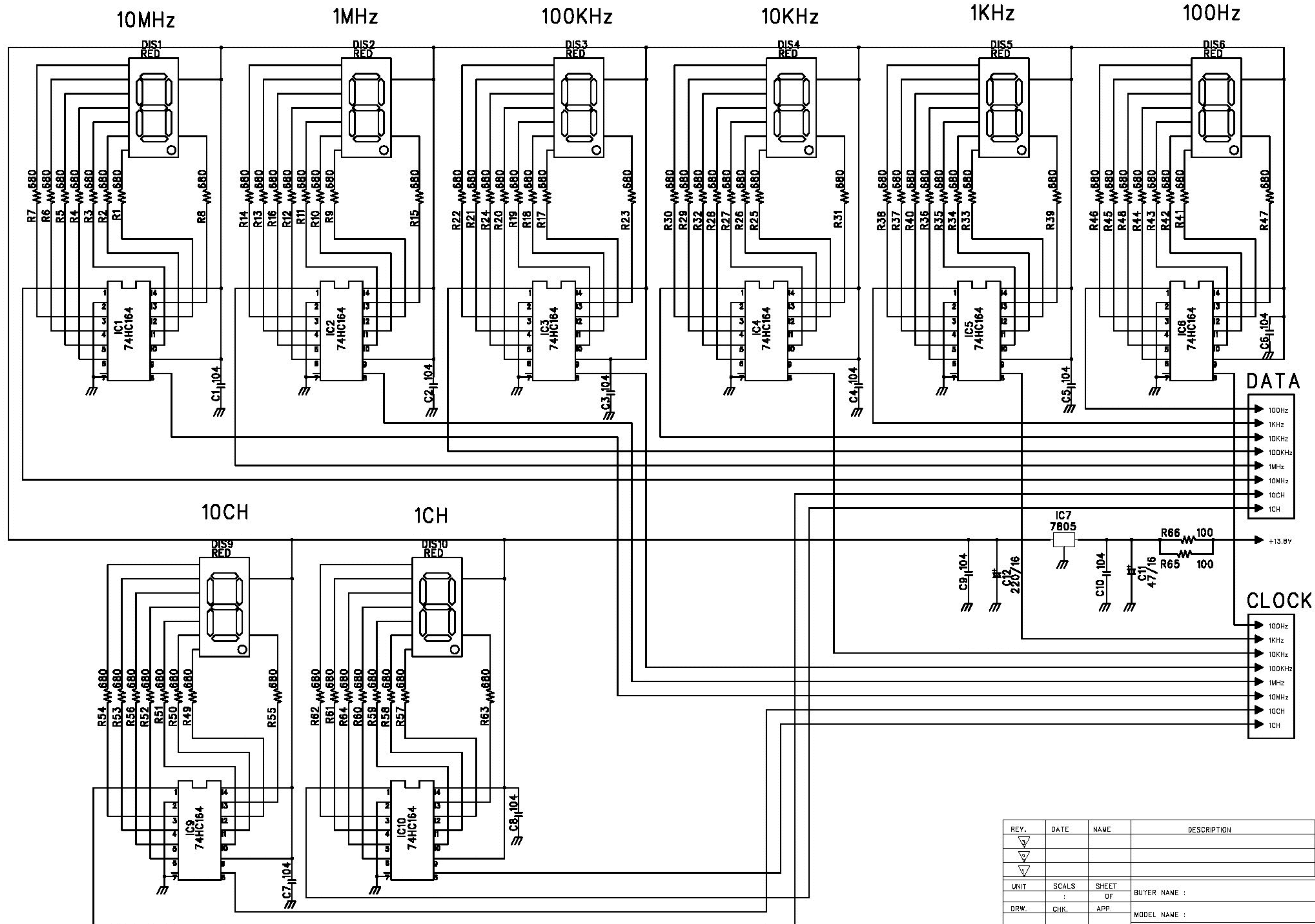

REV.	DATE	NAME	DESCRIPTION	CHECK
UNIT	SCALS	SHEET	BUYER NAME :	
		OF		
DRW.	CHK.	APP.	MODEL NAME :	
			DRAWING NO. :	



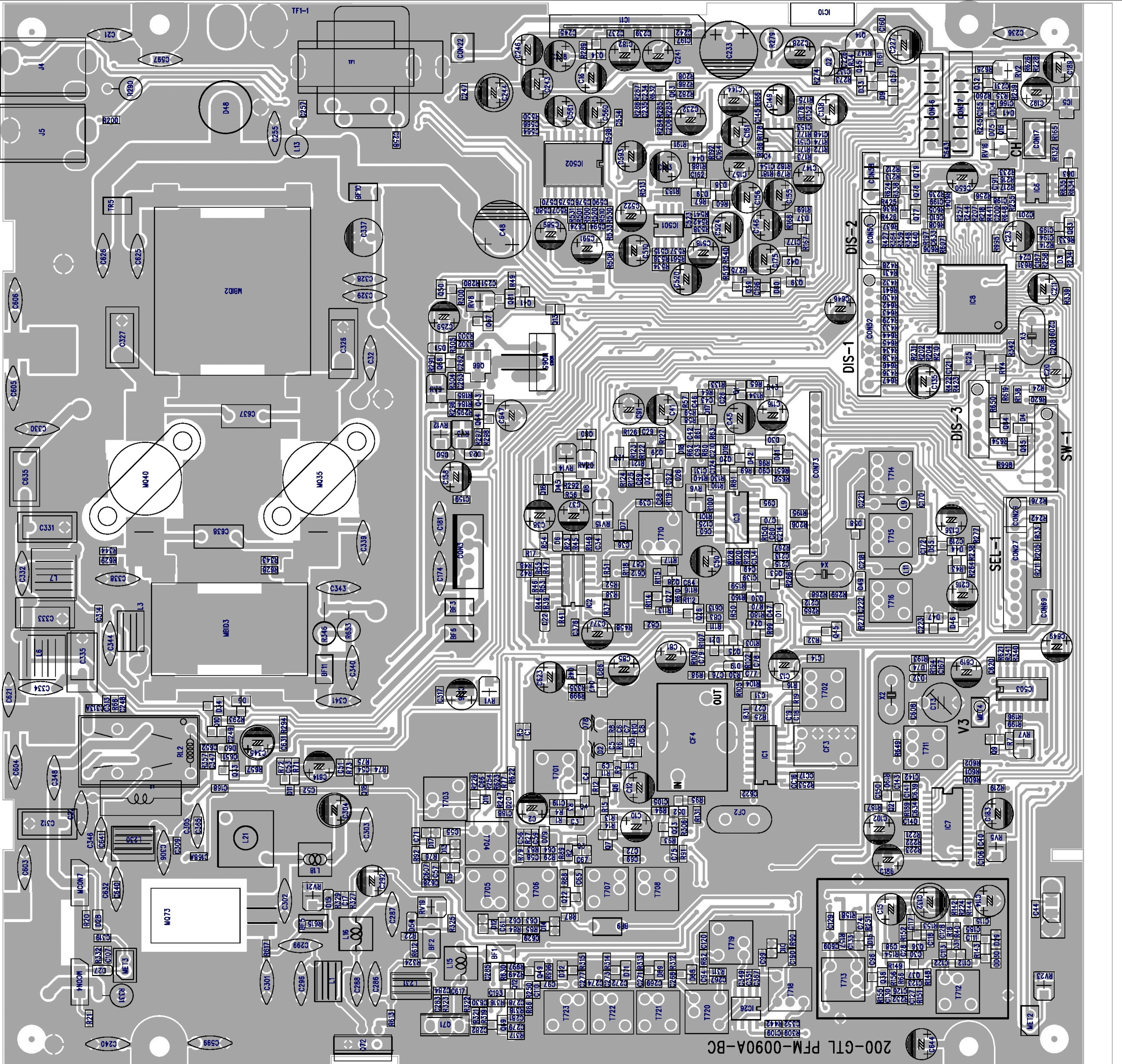
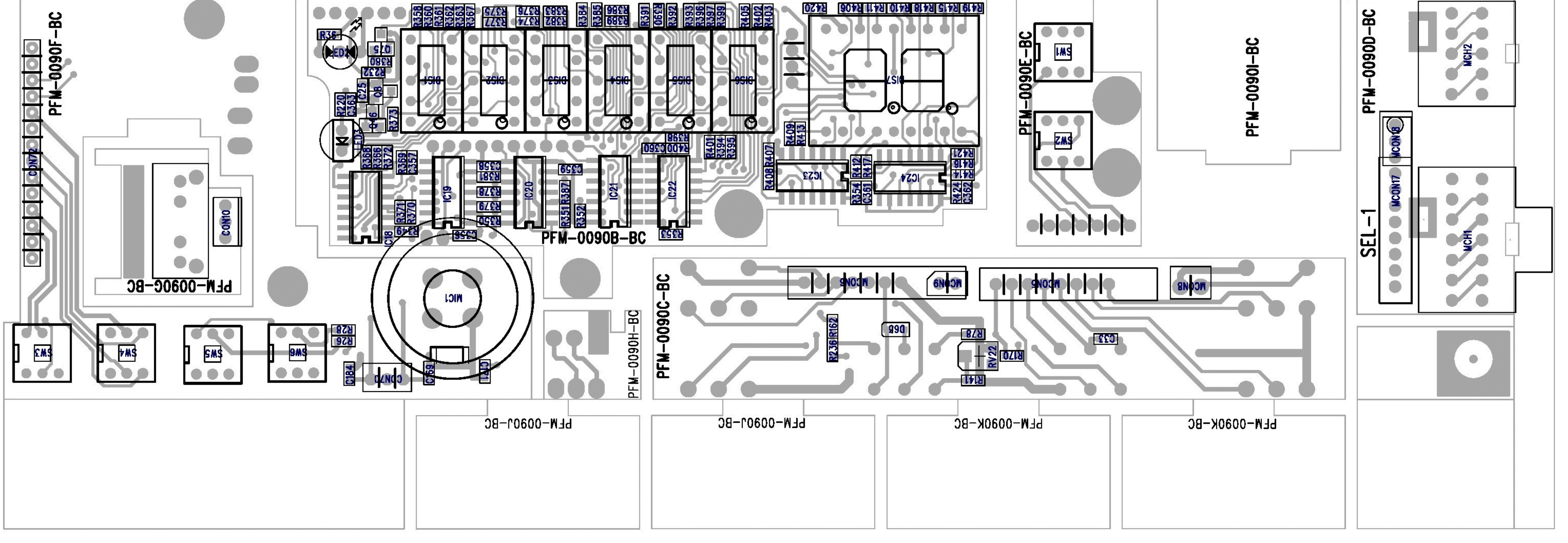







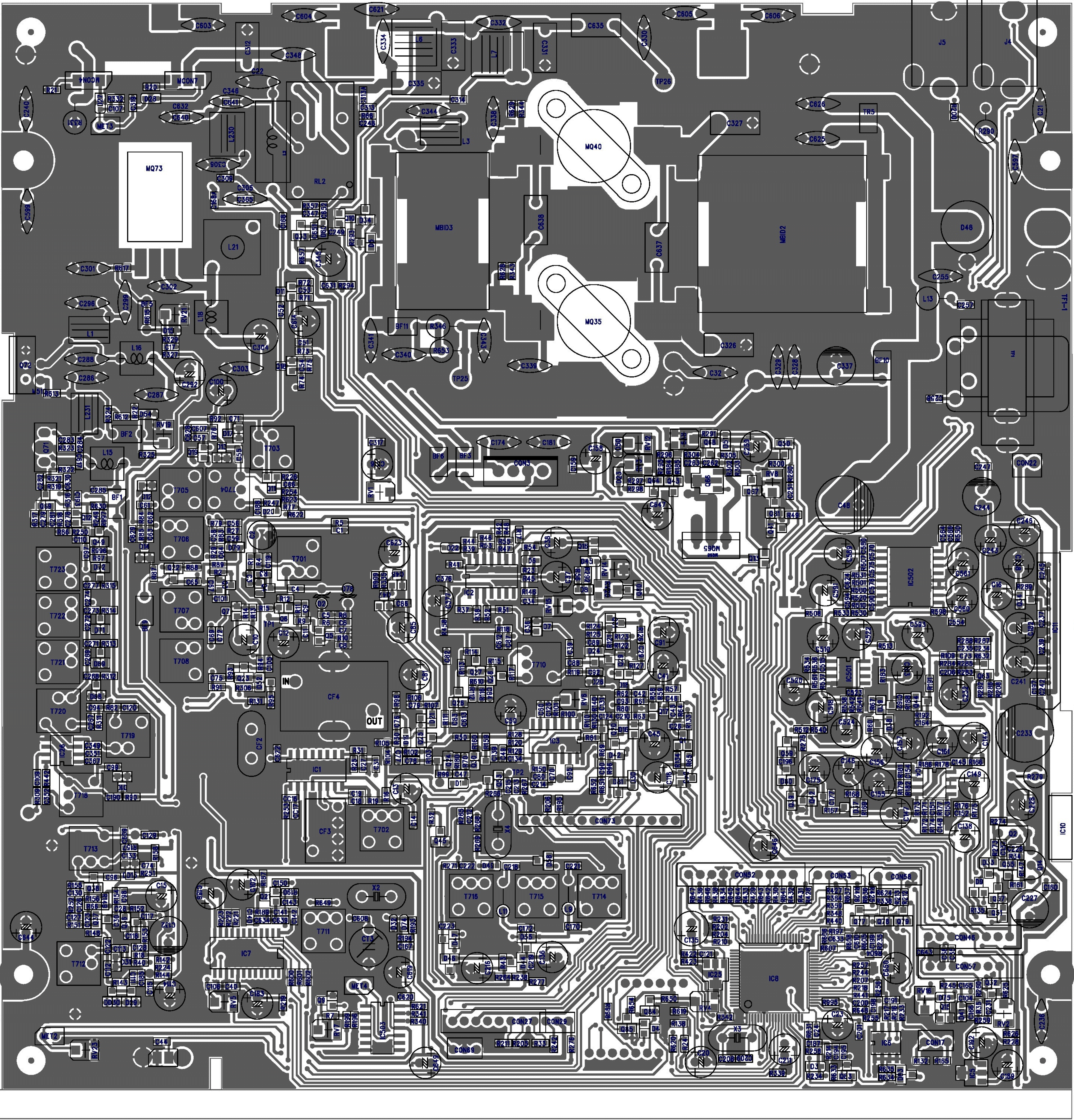
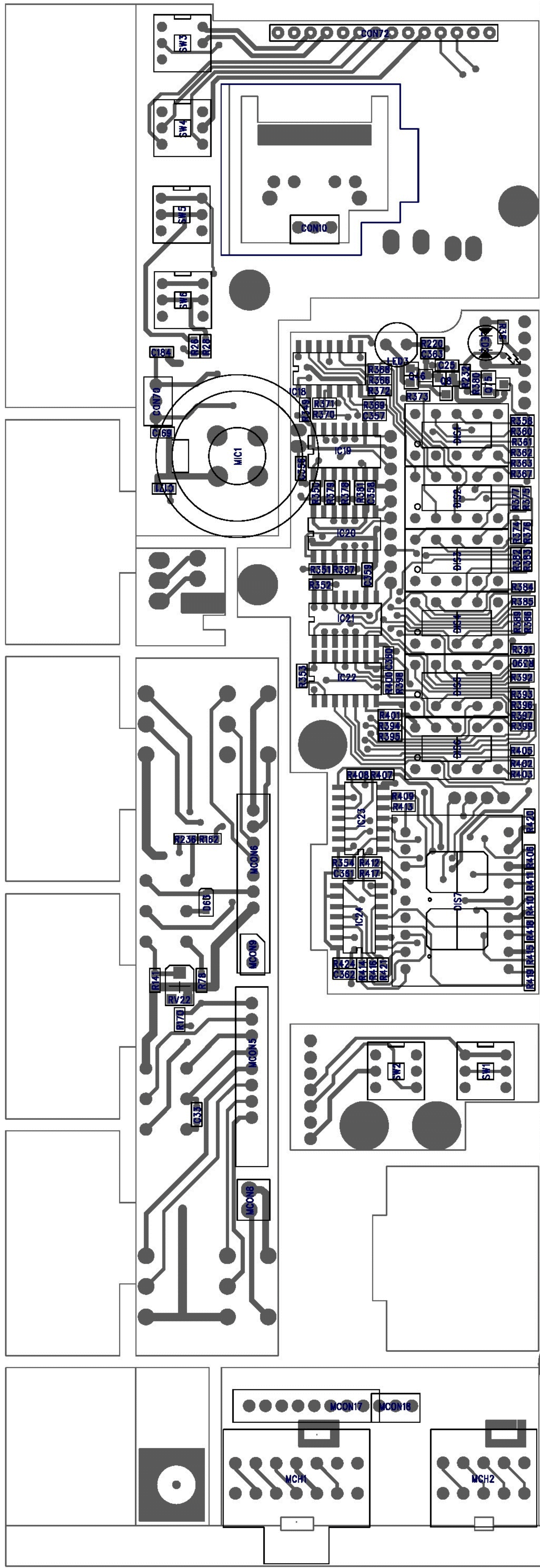



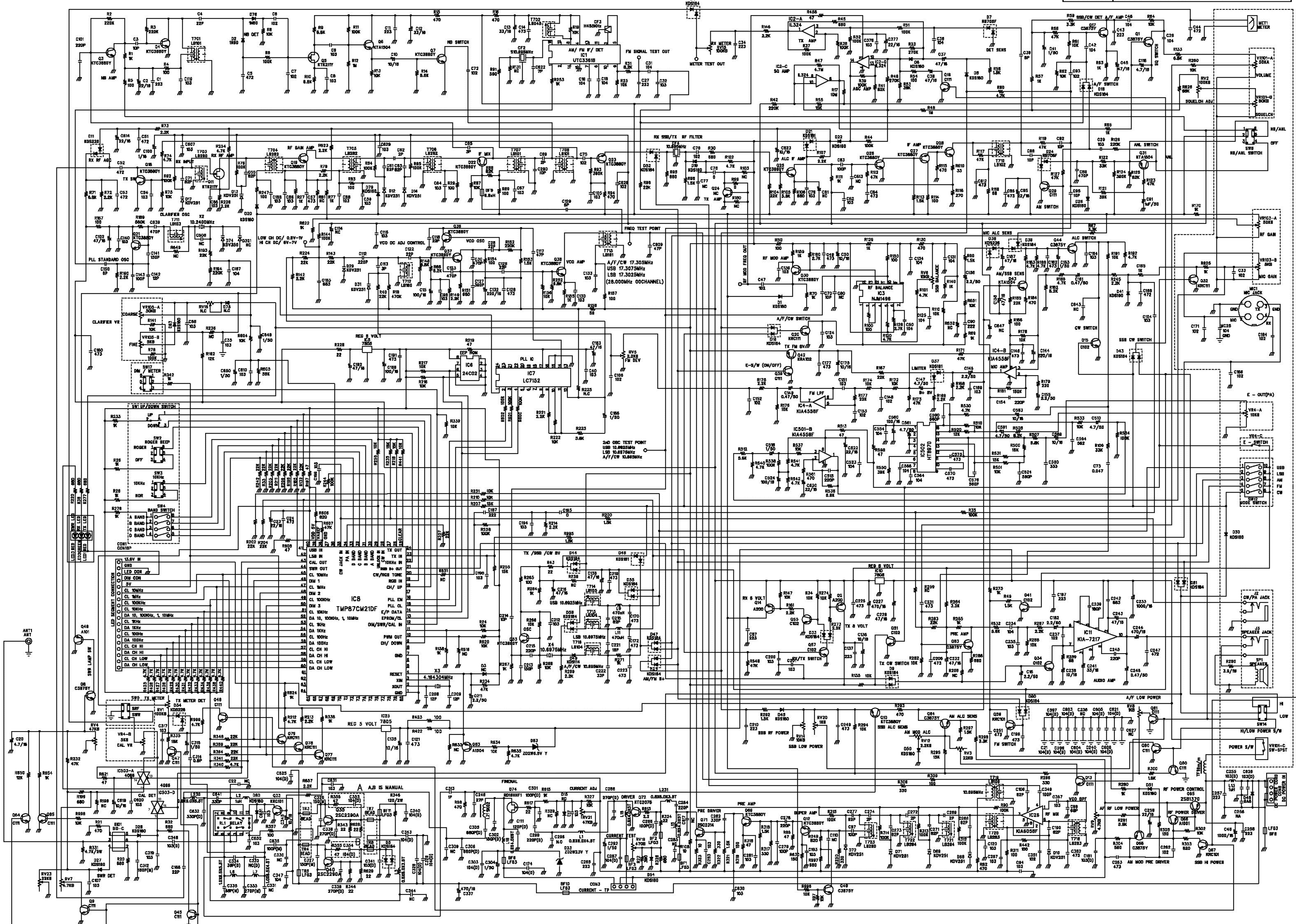



MODEL	200 GTL	REV DATE.	2005. 9. 5
ECO NO.	ELEC-0509-06		

200 GTL

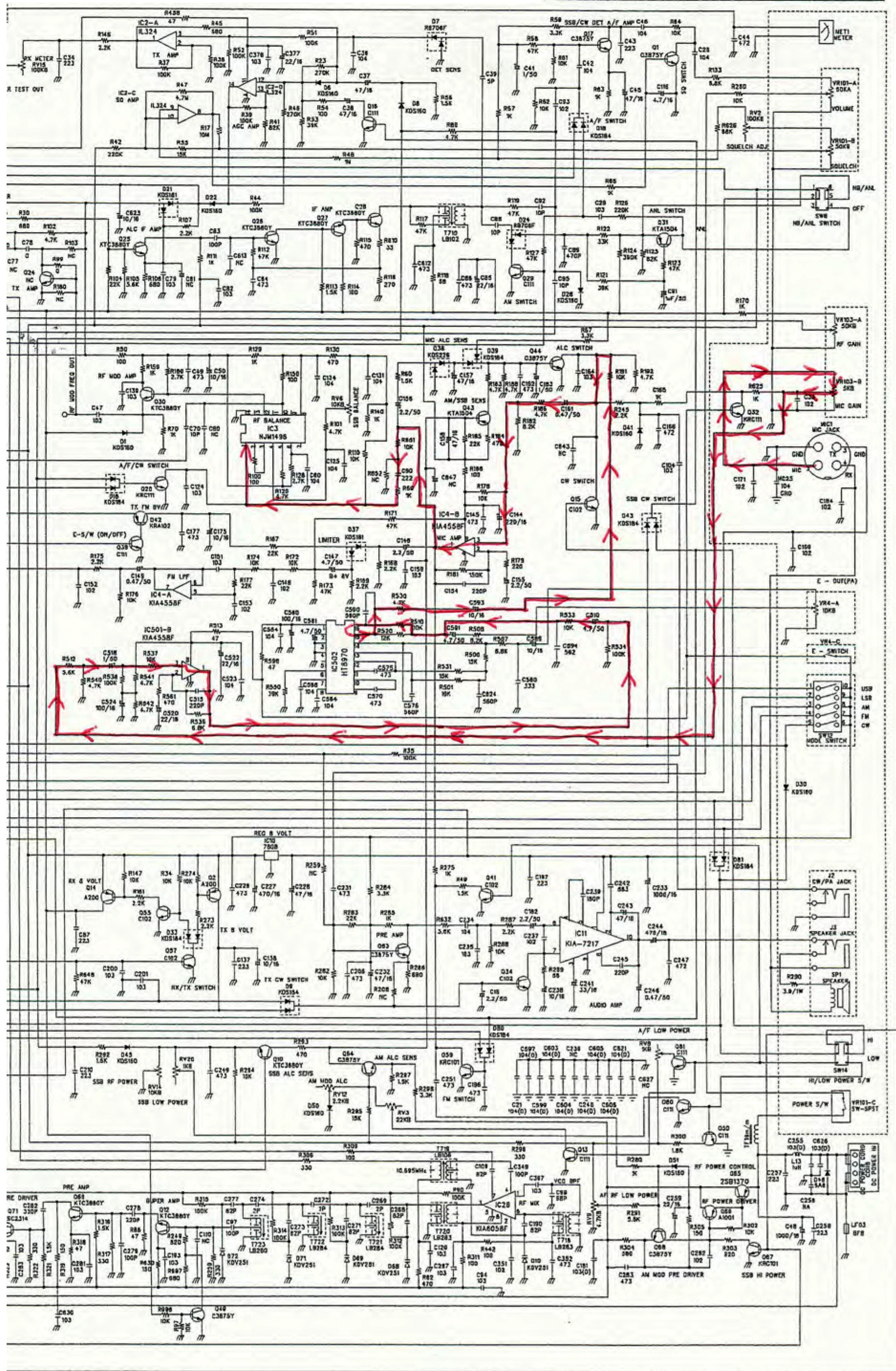

Audio path  
Echo on



MODEL	200 GTL	REV DATE.	2005. 9. 5
ECO NO.	ELEC-0509-06		

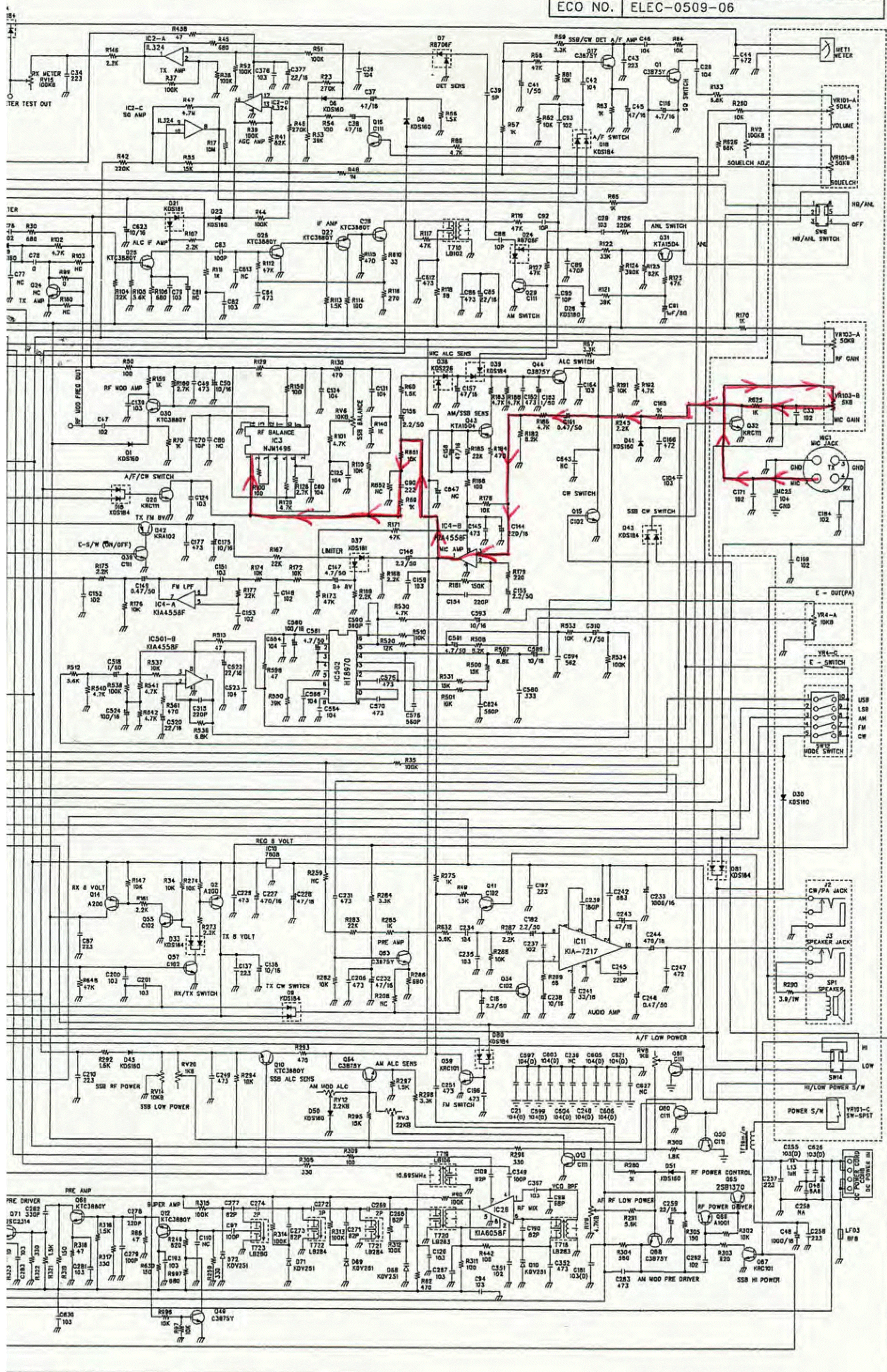

200GTL

Audio Path  
Echo off



## 150GTL & 200GTL Parts List

COBRA P/N	MODEL	DESCRIPTION	CIRCIUT SYMBOL
010-001	150, 200	Bracket, mounting	
010-002	150	Capacitor, trimmer, 20pF, 150gtl	CT1,2
010-003	200	Choke, 4.7 $\mu$ H, 200gtl	L9,11
010-004	150	Choke, 6.8 $\mu$ H, 150gtl	L2
010-005	150, 200	Choke, power input	TF1
010-006	150, 200	Coil, 1 $\mu$ H	150GTL: L13,14,15 200GTL: L2,13
010-007	150, 200	Coil, adjustable	L21
010-008	150, 200	Coil, IFT	T702
010-009	150, 200	Coil, IFT	T701,707,708
010-010	150, 200	Coil, IFT	T719
010-011	150, 200	Coil, IFT	T712
010-012	150, 200	Coil, IFT	150GTL: T713,717 200GTL: T713
010-013	150, 200	Coil, IFT	T703,723
010-014	150, 200	Coil, IFT	T704,705,706
010-015	150, 200	Coil, IFT	T718,720
010-016	150, 200	Coil, IFT	T721,722
010-017	150	Coil, IFT, 150gtl	T710
010-018	200	Coil, IFT, 200gtl	T710
010-019	200	Coil, IFT, 200gtl	T711
010-020	200	Coil, IFT, 200gtl	T715,716
010-021	200	Coil, IFT, 200gtl	T714
010-022	150	Connector assembly, frequency counter, 150gtl	
010-023	150, 200	Connector, antenna	ANT1
010-024	150, 200	Connector, external speaker	150GTL: J4,5 200GTL: J2,3
010-025	150, 200	Connector, microphone	
010-026	150	Cover assembly, bottom, 150gtl	
010-027	200	Cover assembly, bottom, 200gtl	
010-028	150	Cover assembly, top, 150gtl	
010-029	200	Cover assembly, top, 200gtl	
010-030	150	Crystal, 10.24MHz, 150gtl	X1
010-031	200	Crystal, 10.24MHz, 200gtl	X2
010-032	150	Crystal, 10.695MHz, 150gtl	X4
010-033	200	Crystal, 10.6975MHz, 200gtl	X4
010-034	150, 200	Crystal, 4.194304MHz	X3
010-035	150, 200	Diode, 1N60P	150GTL: D2,20 200GTL: D2,78
010-036	150, 200	Diode, 6A6 (6A, 600V)	D48
010-037	200	Diode, band switch, KDS114, 200gtl	D49
010-038	150, 200	Diode, chip, 6.8V zener	150GTL: D79 200GTL: D83
010-039	150, 200	Diode, chip, KDS160	150GTL: D6,22,25,27,28,39,73,77,74 200GTL: D1,6,8,19,20,22,26,27,28,30,41,45,50,51,54,60,63,79,
010-040	150, 200	Diode, chip, KDS181S	150GTL: D21,37 200GTL: D21,37,46
010-041	150, 200	Diode, chip, KDS184S	150GTL: D18,23,33,62,75,78 200GTL: D4,5,9,16,18,33,39,42,43,44,47,52,55,58,80,81
010-042	150, 200	Diode, chip, KDS226	150GTL: D11,34 200GTL: D11,34,38
010-043	150, 200	Diode, chip, varicap, KDV251S-C-RTK	150GTL: D12,13,14,17,30,31,68,69,71,72 200GTL: D10,12,13,14,17,29,31,68,69,71,72
010-044	150, 200	Diode, schottky, RB706F	D7,24
010-045	200	Diode, varicap, KDV350E, 200gtl	D74
010-046	150	Escutcheon assembly, 150gtl	
010-047	200	Escutcheon assembly, 200gtl	



010-048	150, 200	Filter, ceramic, 455KHz	CF3
010-049	150	Heat sink, 150gtl	
010-050	200	Heat sink, 200gtl	
307-331-9-001	200	IC, audio amp, KIA7217AP, 200gtl	IC11
010-051	150	IC, audio amp, TDA2003V, 150gtl	IC9
010-052	150	IC, audio amp, TDA2005, 150gtl	IC11
010-053	150, 200	IC, bipolar, KIA4558F	IC4,501
010-054	150, 200	IC, bipolar, KIA6058F	IC26
010-055	150	IC, CPU, 150gtl	IC8
010-056	200	IC, CPU, 200gtl	IC8
010-057	200	IC, double balanced mod, NJM1496, 200gtl	IC3
010-058	150, 200	IC, echo, HT8970	IC502
010-059	150, 200	IC, EEPROM, HT24LC02	IC6
010-060	150, 200	IC, FM IF, UTC3361B	IC1
010-061	150, 200	IC, IN74HC164AD	150GTL: IC9,12 200GTL: IC18,24
010-062	150, 200	IC, OP AMP, IL324D	IC2
010-063	150, 200	IC, PLL, LC7152	IC7
010-064	150, 200	IC, regulator, KIA7808AP/API	IC10
010-065	150, 200	IC, regulator, KIA78L05F	IC5,25
010-066	200	IC, switch, IW4066BD, 200gtl	IC503
010-067	150, 200	Knob, channel	
010-068	200	Knob, pushbutton, DIM / SWR, 200gtl	
010-069	200	Knob, pushbutton, NB / HI PWR / R BEEP, 200gtl	
010-070	150, 200	Knob, volume (inner)	
010-071	150, 200	Knob, volume (outer)	
010-072	150, 200	Knobe, mode (PA-AM-FM)	
010-073	150, 200	Lamp, meter	LED2
010-074	150, 200	LED, ANT light	LED3
010-075	150, 200	LED, channel display	DIS1, DIS7
010-076	200	LED, frequency display, 200gtl	DIS1,2,3,4,5,6
010-077	150, 200	LED, RX / TX	LED1
010-078	150	MCF, 10.695MHz, 150gtl	
010-079	200	MCF, 10.695MHz, 200gtl	CF2
010-080	200	MCF, 10.695MHz, 200gtl	CF4
010-081	150, 200	Meter, analog	MET1
010-082	150	Pot, DIM / SWR CAL, 150gtl	VR107
010-083	200	Pot, ECHO / SWR CAL, 200gtl	VR4
010-084	150, 200	Pot, MIC GAIN / RF GAIN	150GTL: VR103 200GTL: VR103,105
010-085	150	Pot, TB / ECHO, 150gtl	VR3
010-086	150, 200	Pot, volume / squelch	VR101
010-087	150	Power cord assembly with fuse holder, 150gtl	
010-088	200	Power cord assembly with fuse holder, 200gtl	
010-089	150	Power cord pigtail assembly, 150gtl	CON8
010-090	200	Power cord pigtail assembly, 200gtl	
010-091	150, 200	Power supply assembly, EL	
010-092	200	Relay, 200gtl	RL1
010-093	150	Resistor, 10ohm 1W 5%, 150gtl	R279
010-094	200	Resistor, 120ohm 2W 5%, 200gtl	R346,355,356
010-095	150, 200	Resistor, 3.9ohm 2W 5%	R290
010-096	150, 200	Resistor, 4.7K 2W 5%	R331
010-097	150, 200	Resistor, trimmer, 100K	RV1,2,15
010-098	150, 200	Resistor, trimmer, 10K	150GTL: RV4 200GTL: RV6,14
010-099	200	Resistor, trimmer, 1K, 200gtl	RV8,20
010-100	150, 200	Resistor, trimmer, 2.2K	150GTL: RV12 200GTL: RV5,12
010-101	200	Resistor, trimmer, 22K, 200gtl	RV3,23



010-102	150, 200	Resistor, trimmer, 4.7K	150GTL: RV5,9 200GTL: RV7,9
010-103	200	Resistor, trimmer, 470ohm, 200gtl	RV19
010-104	150, 200	Resistor, trimmer, 47K	150GTL: RV3,17 200GTL: RV4,21
010-105	150, 200	Screw, case	
010-106	150, 200	Speaker	SP1
010-107	150	Strain relief, power cord, 150gtl	
010-108	200	Strain relief, power cord, 200gtl	
010-109	150, 200	Switch, band (A-B-C-D)	SW4
010-110	150, 200	Switch, channel	SW1
010-111	200	Switch, mode (CW-FM-AM-USB-LSB), 200gtl	SW12
010-112	150	Switch, mode (PA-AM-FM), 150gtl	SW11
010-113	200	Switch, push, DIM/SWR, 200gtl	SW17
010-114	200	Switch, push, NB, PWR, R BEEP, 10KHz, SWR-S/RF, 200	SW2,3,5,8,14
010-115	150	Switch, slide (RF Power, 10KHz), 150gtl	SW3,14
010-116	150	Switch, slide (S/RF, NB/ANL), 150gtl	SW7,9
010-117	150, 200	Thumbscrew, for mounting radio to bracket	
010-118	150	Transformer, audio, 150gtl	
172-062-9-001	200	Transistor, 2SC2078, 200gtl	Q72
010-119	200	Transistor, 2SC2290A, 200gtl	Q35,40
010-120	150, 200	Transistor, 2SC2314	Q71
010-121	150	Transistor, driver, RD06HHF1 (30MHz, 6W), 150gtl	Q72
010-122	150, 200	Transistor, KRA101S	150GTL: Q8 200GTL: Q46
010-123	150, 200	Transistor, KRA102S	Q42
010-124	150	Transistor, KRC101S, 150gtl	Q33,59,67
010-125	150, 200	Transistor, KRC102S	150GTL: Q55,57 200GTL: Q15,34,41,55,57
010-126	150, 200	Transistor, KRC111S	150GTL: Q9,25,32,39,59,79,80 200GTL: Q9,13,16,20,29,32,39,45,47,48,50,77-81,84,85
010-127	150, 200	Transistor, KTA1001	Q66
010-128	150, 200	Transistor, KTA1504GR	150GTL: Q6,31,43,81 200GTL: Q6,31,43,83
010-129	150, 200	Transistor, KTB1370	Q65
010-130	150, 200	Transistor, KTC3875Y	150GTL: Q1,10,13,17,26,28,44,64,68 200GTL: Q1,8,17,44,49,63,64,68,75
010-131	150, 200	Transistor, KTC3880S-Y	150GTL: Q3,4,7,12,16,19,22,30,31,36,40,53,63,73 200GTL: Q2,4,7,10,12,18,19,21,22,22,25,26,27,29,29,29,29,52,60
010-132	150, 200	Transistor, PNP, KTA200	Q2,14
010-133	150, 200	Transistor, RD16HHF1 (30MHz, 16W)	150GTL: Q73,74 200GTL: Q74
010-134	150, 200	Transistor., KTK211Y	Q5,11
010-135	150, 200	Washer, rubber (for thumb screws)	



To change the talkback volume, adjust R109 (higher value = lower volume)





TEST CONDITION:  
 SUPPLY VOLTAGE: 13.8 V  
 BAND A ( 28.000 MHz)

LOCATION	VALUE	SWITCH CONDITION		UNIT	CW	FM	AM	USB	LSB
Q40	2S62290	RX STANDBY CONDITION	B	V	0	0	0	0	0
			E	V	0	0	0	0	0
			C	V	13.8	13.8	13.8	13.8	13.8
		TX LOW POWER	B	V	0.4	0.4	0.4	0.3	0.3
			E	V	0	0	0	0	0
			C	V	13.5	13.5	13.5	13.3	13.4
		TX HI POWER	B	V	0.2	0.2	0.2	-0.2	-0.2
			E	V	0	0	0	0	0
			C	V	13.1	13.1	13.1	12.4	12.2
Q53	ICTC3880Y	RX	B	V	3.1	0	0	2.8	2.8
			E	V	2.5	0	0	2.2	2.2
			C	V	6.6	0	0	6	6
		TX	B	V	3	3	3	3	3
			E	V	2.5	2.3	2.3	2.4	2.4
			C	V	6.6	6.3	6.3	6.3	6.3
Q49	Q3875Y	RX STANDBY CONDITION	B	V	0.6	0.6	0.6	0.6	0.6
			E	V	0	0	0	0	0
			C	V	0	0	0	0	0
		TX LOW POWER	B	V	0.2	0.2	0.2	0	0
			E	V	0	0	0	0	0
			C	V	4.7	4.7	4.7	4.7	4.7
		TX HI POWER	B	V	0	0	0	-0.9	-0.8
			E	V	0	0	0	0	0
			C	V	4.7	4.7	4.7	4.7	4.7
Q33	KRC 101	RX	B	mV	86	86	86	86	86
			E	V	0	0	0	0	0
			C	V	13.8	13.8	13.8	13.8	13.8
		TX	B	V	5.4	5.4	5.4	5.4	5.4
			E	V	0	0	0	0	0
			C	mV	60	60	60	60	60
Q83	A1504	RX	B	V	6.9	6.8	6.9	6.9	6.9
			E	V	4.9	4.9	4.9	4.9	4.9
			C	V	0	0	0	0	0
		TX	B	V	6.4	6.4	6.4	6.7	6.7
			E	V	4.9	4.9	4.9	4.9	4.9
			C	V	0	0	0	0	0
Q77	KRC111	RX	B	mV	53	53	53	53	53
			E	V	0	0	0	0	0
			C	V	13.3	13.3	13.3	13.3	13.3
		OCCUR WHEN PRESSING DIM SW. TO 3,4&5	B	V	2	2	2	2	2
			E	V	0	0	0	0	0
			C	mV	65	65	65	65	65



LOCATION	VALUE	SWITCH CONDITION		UNIT	CW	FM	AM	USB	LSB	
Q78	KRC111	RX/TX DIM SWITCH AT NORMAL CONDITION	B	mV	53	53	53	53	53	
			E	V	0	0	0	0	0	
			C	V	13.3	13.3	13.3	13.3	13.3	
		OCCUR WHEN PRESSING DIM SW. TO 2,4&5 TIMES	B	V	2	2	2	2	2	2
			E	V	0	0	0	0	0	0
			C	mV	49	49	49	49	49	
Q79	KRC111	RX/TX DIM SWITCH AT NORMAL CONDITION	B	mV	52	52	52	52	52	
			E	V	0	0	0	0	0	
			C	V	13.3	13.3	13.3	13.3	13.3	
		OCCUR WHEN PRESSING DIM SW. TO 1&5 TIMES	B	V	1.9	1.9	1.9	1.9	1.9	1.9
			E	V	0	0	0	0	0	0
			C	mV	3.6	3.6	3.6	3.6	3.6	
Q45	C111	TX LOW POWER	B	V	0	0	0	0	0	
			E	V	0	0	0	0	0	
			C	V	2.5	2.5	2.6	5.4	5.4	
		TX HIGH POWER	B	V	7.2	7.2	7.2	0	0	
			E	V	0	0	0	0	0	
			C	V	0	0	0	5.8	5.8	
Q9	C111	TX LOW POWER	B	V	0	0	0	0	0	
			E	V	0	0	0	0	0	
			C	V	1.2	1.2	1.2	3.3	3.3	
		TX HIGH POWER	B	V	7.2	7.2	7.2	0	0	
			E	V	0	0	0	0	0	
			C	V	0	0	0	5.7	5.7	
Q 48	C111	TX LOW POWER CAL FUNCTION OFF	B	V	0	0	0	0	0	
			E	V	0	0	0	0	0	
			C	V	2	2	2	4	4	
		TX LOW POWER CAL FUNCTION ON	B	V	0	0	0	0	0	
			E	V	0	0	0	0	0	
			C	V	4	4	4	9	9	
		TX HI POWER CAL FUNCTION OFF	B	V	0	0	0	7.2	7.2	
			E	V	0	0	0	0	0	
			C	V	5	5	5	0	0	
		TX HI POWER CAL FUNCTION ON	B	V	0	0	0	7.2	7.2	
			E	V	0	0	0	0	0	
			C	V	6	6	6	0	0	
Q 47	C111	TX LOW POWER CAL FUNCTION OFF	B	V	0	0	0	0	0	
			E	V	0	0	0	0	0	
			C	V	2	2	2	4	4	
		TX LOW POWER CAL FUNCTION ON	B	V	0	0	0	0	0	
			E	V	0	0	0	0	0	
			C	V	4.5	4.5	4.5	9	9	
		TX HI POWER CAL FUNCTION OFF	B	V	7.2	7.2	7.2	0	0	
			E	V	0	0	0	0	0	
			C	V	0	0	0	5	5	
		TX HI POWER CAL FUNCTION ON	B	V	7.2	7.2	7.2	0	0	
			E	V	0	0	0	0	0	
			C	V	0	0	0	6	6	



LOCATION	VALUE	SWITCH CONDITION		UNIT	CW	FM	AM	USB	LSB
Q63	KTC 3880Y	RX	B	V	1.28	1.28	1.28	1.28	1.28
			E	V	0.657	0.657	0.657	0.657	0.657
			C	V	3.3	3.3	3.3	3.3	3.3
Q34	C102	RX MOD	B	V	1.1	1.1	1.1	1.1	1.1
			E	V	0	0	0	0	0
			C	V	3.4	3.4	3.4	3.4	3.4
Q81	C111	RX PWR SW SET TO LOW POWER	B	V	7.2	7.2	7.2	0	0
			E	V	0	0	0	0	0
			C	V	42.5 Mv	42.5 Mv	42.5 Mv	6.28	6.28
		RX PWR SW SET TO LOW POWER	B	V	0	0	0	0	0
			E	V	0	0	0	0	0
			C	V	7.35	7.35	7.35	7.35	7.35
		TX PWR SW SET TO LOW POWER	B	V	7.2	7.2	7.2	0	0
			E	V	0	0	0	0	0
			C	mV	41.8	41.7	41.7	6.28	6.28
		TX PWR SW SET TO LOW POWER	B	V	0	0	0	0	0
			E	V	0	0	0	0	0
			C	V	7.54	7.54	7.54	7.54	7.54
Q50	C111	RX	B	V	0	0	0	0	0
			E	V	0	0	0	0	0
			C	V	7.35	7.35	7.35	7.35	7.35
		TX	B	V	0	0	0	0	0
			E	V	0	0	0	0	0
			C	V	7.35	7.35	7.35	7.35	7.35
Q80	C111	RX SW SET TO LOW POWER	B	V	0	0	0	7.15	7.15
			E	V	0	0	0	0	0
			C	V	2.26	5	5	0	0
		RX SW SET TO HI POWER	B	V	0	0	0	0	0
			E	V	0	0	0	0	0
			C	V	2.26	5.09	5.09	2.26	2.26
		TX PWR SW SET TO LOW POWER	B	V	0	0	0	7.24	7.24
			E	V	0	0	0	0	0
			C	V	2.26	5.09	5.09	0	0
		TX PWR SW SET TO LOW POWER	B	V	0	0	0	0	0
			E	V	0	0	0	0	0
			C	V	2.26	5.09	5.09	2.26	2.26
Q13	C111	RX MODE SW SET HI POWER	B	V	0	0	0	0	0
			E	V	0	0	0	0	0
			C	V	0.89	0.89	0.89	0.89	0.89
		RX MODE SW SET LO POWER	B	V	7.23	7.26	7.26	0	0
			E	V	0	0	0	0	0
			C	V	0	0	0	0.89	0.89
		TX MODE SW SET HI POWER	B	V	0	0	0	0	0
			E	V	0	0	0	0	0
			C	V	0.89	0.89	0.89	0.89	0.89
		TX MODE SW SET LO POWER	B	V	7.23	7.26	7.26	0	0
			E	V	0	0	0	0	0
			C	mV	2.4	2.4	29	0.89 V	0.89 V



LOCATION	VALUE	SWITCH CONDITION		UNIT	CW	FM	AM	USB	LSB
Q65	2SB1370	RX OPERATION SW SET TO LOW POWER	B	V	13.3	13.3	13.3	13.3	13.3
			E	V	13.8	13.8	13.8	13.8	13.8
			C	V	1.58	1.58	1.58	2.8	2.8
		RX OPERATION SW SET TO HI POWER	B	V	13.3	13.3	13.3	13.2	13.2
			E	V	13.8	13.8	13.8	13.8	13.8
			C	V	3.4	3.4	3.4	3.4	3.4
		TX OPERATION SW SET TO LOW POWER	B	V	13	13	13	13	13
			E	V	13.7	13.7	13.7	13.66	13.66
			C	V	1.46	1.46	1.47	1.47	1.47
		TX OPERATION SW SET TO HI POWER	B	V	1.28	1.28	1.28	1.28	1.28
			E	V	13.4	13.4	13.4	13.4	13.4
			C	V	3.3	3.3	3.3	12.3	12.8
Q66	A1001	RX OPERATION SW SET TO LOW POWER	B	V	13.3	13.3	13.3	13.3	13.3
			E	V	13.3	13.3	13.3	13.3	13.3
			C	V	1.6	1.6	1.6	2.8	2.8
		RX OPERATION SW SET TO HI POWER	B	V	13.3	13.6	13.3	12.5	12.5
			E	V	13.3	13.3	13.3	13.2	13.2
			C	V	3.4	3.4	3.4	13.2	13.2
		TX OPERATION SW SET TO LOW POWER	B	V	12.5	12.5	12.5	12.4	12.4
			E	V	13	13	13	13	13
			C	V	1.47	1.47	1.47	2.7	2.7
		TX OPERATION SW SET TO HI POWER	B	V	12.2	12.2	12.2	11.6	11.5
			E	V	12.7	12.7	12.7	12.2	12.16
			C	V	3.3	3.3	3.3	12.2	12.3
Q67	KRC101	RX OPERATION SW SET TO LOW POWER	B	V	0	0	0	0	0
			E	V	0	0	0	0	0
			C	V	13.3	13.3	13.3	13.3	13.3
		RX OPERATION SW SET TO HI POWER	B	V	0	0	0	7.16	7.16
			E	V	0	0	0	0	0
			C	V	13.28	13.28	13.28	48.6mV	49.1mV
		TX OPERATION SW SET TO LOW POWER	B	V	0	0	0	0	0
			E	V	0	0	0	0	0
			C	V	12.5	12.5	12.5	12.5	12.5
		TX OPERATION SW SET TO HI POWER	B	V	-0.05	-0.05	-0.05	7.12	7.1
			E	V	0	0	0	0	0
			C	V	12.3	12.3	12.3	0	0
Q68	C3875Y	RX OPERATION SW SET TO LOW POWER	B	V	2	2	2	3.3	3.3
			E	V	1.59	1.59	1.59	2.8	2.8
			C	V	13.3	13.3	13.3	13.3	13.3
		RX OPERATION SW SET TO HI POWER	B	V	3.8	3.8	3.8	11.8	11.8
			E	V	3.4	3.4	3.4	12.6	12.6
			C	V	13.3	13.26	13.3	12.5	12.5
		TX OPERATION SW SET TO LOW POWER	B	V	2	2	2	3.3	3.3
			E	V	1.5	1.5	1.5	2.7	2.7
			C	V	12.5	12.5	12.5	12.5	12.5
		TX OPERATION SW SET TO HI POWER	B	V	11.8	11.8	11.8	11.5	11.5
			E	V	3.3	3.3	3.3	11.9	11.9
			C	V	12.3	12.3	12.3	11.8	11.8



LOCATION	VALUE	SWITCH CONDITION		UNIT	CW	FM	AM	USB	LSB	
Q12	KTC3880Y	RX MODE	B	mV	1.3	1.3	1.3	1.3	1.3	
			E	V	0	0	0	0	0	
			C	mV	108	108	108	108	108	
		TX OPERATION SW SET TO LOW POWER		B	V	1.3	1.3	1.3	1.3	1.3
				E	V	0.59	0.59	0.59	0.59	0.59
				C	V	5.7	5.7	5.7	5.7	5.7
		TX OPERATION SW SET TO HI POWER		B	V	1.3	1.3	1.3	1.3	1.3
				E	V	0.59	0.58	0.58	0.59	0.59
				C	V	0.57	0.57	0.57	0.57	0.57
Q69	KTC3880Y	RX MODE	B	mV	19.2	19.2	19.2	19.2	19.2	
			E	V	0	0	0	0	0	
			C	mV	107	107	107	107	107	
		TX OPERATION SW SET TO LOW POWER		B	V	1.2	1.2	1.2	1.2	1.2
				E	V	0.58	0.58	0.58	0.58	0.58
				C	V	5.8	5.8	5.8	5.8	5.8
		TX OPERATION SW SET TO HI POWER		B	V	1.2	1.2	1.2	1.2	1.2
				E	V	0.58	0.57	0.57	0.56	0.56
				C	V	5.8	5.8	5.8	5.8	5.8
Q71	2SC2314	RX MODE	B	V	19.2	19.2	19.2	19.2	19.2	
			E	V	0	0	0	0	0	
			C	mV	107.9	107	107	107	107	
		TX OPERATION SW SET TO LOW POWER		B	V	1.28	1.27	1.27	1.28	1.28
				E	V	0.65	0.65	0.65	0.65	0.65
				C	V	7.5	7.5	7.5	7.5	7.5
		TX OPERATION SW SET TO HI POWER		B	V	1.28	1.28	1.28	1.28	1.28
				E	V	0.65	0.65	0.65	0.61	0.61
				C	V	7.5	7.5	7.5	7.5	7.5
Q72	KTC2078	RX OPERATION SW SET TO LOW POWER	B	mV	12	12	12	12	12	
			E	V	0	0	0	0	0	
			C	V	1.6	1.6	1.6	2.8	2.8	
		RX OPERATION SW SET TO HI POWER		B	mV	12	12	12	12	12
				E	V	0	0	0	0	0
				C	V	3.4	3.4	3.4	13.25	13.25
		TX OPERATION SW SET TO LOW POWER		B	V	0.6	0.6	0.6	0.64	0.64
				E	V	0	0	0	0	0
				C	V	1.46	1.46	1.46	2.7	2.7
		TX OPERATION SW SET TO HI POWER		B	V	0.62	0.62	0.62	0.64	0.64
				E	V	0	0	0	0	0
				C	V	3.3	3.3	3.3	12.2	12.2
Q74	RD1GHHF1	RX OPERATION SW SET TO LOW POWER	G	mV	79.7	79.7	79.7	79.7	79.7	
			D	V	0	0	0	0	0	
			S	V	1.6	1.6	1.6	2.8	2.8	
		RX OPERATION SW SET TO HI POWER		G	mV	79.7	79.7	79.7	79.7	79.7
				D	V	0	0	0	0	0
				S	V	3.4	3.4	3.4	13.2	13.2
		TX OPERATION SW SET TO LOW POWER		G	V	5.6	5.6	5.6	5.6	5.6
				D	V	0	0	0	0	0
				S	V	1.49	1.49	1.49	2.66	2.66
		TX OPERATION SW SET TO HI POWER		G	V	5.5	5.5	5.5	5.6	5.6
				D	V	0	0	0	0	0
				S	V	3.2	3.2	3.2	11.8	11.8



LOCATION	VALUE	SWITCH CONDITION		UNIT	CW	FM	AM	USB	LSB
Q35	2SC2290	RX MODE	B	V	0	0	0	0	0
			E	V	0	0	0	0	0
			C	V	13.8	13.8	13.8	13.8	13.8
		TX OPERATION SW SET TO LOW POWER	B	V	0.5	0.5	0.5	0.6	0.6
			E	V	0	0	0	0	0
			C	V	13.5	13.5	13.5	13.3	13.3
		TX OPERATION SW SET TO HI POWER	B	V	0.2	0.2	0.2	0.5	0.5
			E	V	0	0	0	0	0
			C	V	13.1	13.1	13.1	12.3	12.3
Q18	KTC3880Y	TX MODE	B	V	0.733	0.733	0.733	0.733	0.733
			E	V	0	0	0	0	0
			C	V	0	0	0	0	0
Q30	KTC3880Y	RX MODE	B	V	0.978	0.978	0.978	0.978	0.978
			E	V	7.08	7.08	7.08	7.08	7.08
			C	mV	345	345	345	345	345
		TX MODE	B	V	3.58	3.56	3.56	3.52	3.52
			E	V	2.58	2.58	2.58	2.58	2.58
			C	V	3.95	3.88	3.88	3.95	3.95
Q20	KRC111	RX MODE	B	V	7.3	6.6	6.6	0	0
			E	V	0	0	0	0	0
			C	mV	2.6	2.6	2.6	61.2	61.2
		TX MODE	B	V	7.4	6.7	6.7	0	0
			E	V	0	0	0	0	0
			C	mV	3	3	3	2.58V	2.58V
Q42	KRA102	RX MODE	B	mV	107.8	2.8	108	108	108
			E	mV	108	108	108	108	108
			C	mV	89.1	87	86	85	84.5
		TX MODE	B	V	7.58	4.8mV	7.56	7.59	7.59
			E	V	7.6	7.6	7.6	7.6	7.6
			C	mV	108	7.57	108	108	108
Q39	C111	RX MODE	B	mV	41	7.9V	89	192	21
			E	V	0	0	0	0	0
			C	mV	108	2.8	108	108	108
		TX MODE	B	mV	19.5	7.9V	56.5	30	18
			E	V	0	0	0	0	0
			C	V	7.6	4.8mV	7.6	7.5	7.5
Q43	KTA1504	RX MODE	B	V	7.87	7.87	7.87	7.87	7.87
			E	V	7.89	7.89	7.89	7.89	7.89
			C	V	0.727	0.727	0.727	0.727	0.727
		TX MODE	B	V	7.87	7.87	7.87	7.87	7.87
			E	V	7.89	7.89	7.89	7.89	7.89
			C	V	156.4	155.4	155.2	155.9	155.9
Q44	C3875	RX MODE	B	V	0.725	0.725	0.725	0.725	0.725
			E	V	0	0	0	0	0
			C	mV	4.1	4.5	4.5	4.5	4.5
		TX MODE	B	mV	157.6	156.4	156.2	157.2	157.2
			E	V	0	0	0	0	0
			C	V	0	0	0	0	0



LOCATION	VALUE	SWITCH CONDITION		UNIT	CW	FM	AM	USB	LSB	
Q15	C102	RX MODE	B	V	7.88	0	0	0	0	
			E	V	0	0	0	0	0	
			C	mV	4.1	4.5	4.5	4.5	4.5	
		TX MODE	B	V	7.88	0	0	0	0	0
			E	V	0	0	0	0	0	0
			C	mV	2.6	0	0	0	0	0
Q14	A200	RX MODE	B	V	7.1	7.1	7.1	7.1	7.1	
			E	V	7.9	7.9	7.9	7.9	7.9	
			C	V	7.8	7.8	7.8	7.8	7.8	
		TX MODE	B	V	7.9	7.9	7.9	7.9	7.9	
			E	V	7.9	7.9	7.9	7.9	7.9	
			C	V	0.684	0.684	0.684	0.684	0.684	
Q55	C102	RX MODE	B	V	4.2	4.2	4.2	4.2	4.2	
			E	V	0	0	0	0	0	
			C	mV	31.4	31.4	31.4	31.4	31.4	
		TX MODE	B	V	0.588	0.588	0.588	0.591	0.591	
			E	V	0	0	0	0	0	
			C	V	7.9	7.9	7.9	7.8	7.8	
Q57	C102	RX MODE	B	mV	20.9	20.9	20.9	20.9	20.9	
			E	V	0	0	0	0	0	
			C	V	7.7	7.7	7.7	7.7	7.7	
		TX MODE	B	V	4.7	4.7	4.7	4.7	4.7	
			E	V	0	0	0	0	0	
			C	mV	30	30	30	30	30	
Q41	C102	RX OPERATION SW SET TO LOW POWER	B	V	7.2	7.2	7.2	0	0	
			E	V	0	0	0	0	0	
			C	mV	11	3.4	11	15.5	15.5	
		RX OPERATION SW SET TO HI POWER	B	V	0	0	0	0	0	
			E	V	0	0	0	0	0	
			C	V	3.3	14.9mV	3.3	15.6mV	15.5mV	
		TX OPERATION SW SET TO LOW POWER	B	V	7.2	7.2	7.2	0	0	
			E	V	0	0	0	0	0	
			C	mV	10	2.4	10	14.7	14.7	
		TX OPERATION SW SET TO HI POWER	B	V	0	0	0	0	0	
			E	V	0	0	0	0	0	
			C	mV	3.3V	12.9	3.3	14.5	14.6	
Q17	C3875Y	RX MODE	B	V	1.23	1.23	1.23	1.23	1.23	
			E	V	0.615	0.61	0.61	0.616	0.618	
			C	V	5.12	5.14	5.15	5.12	5.12	
Q16	C111	RX MODE	B	V	7.31	0	0	6.5	6.5	
			E	V	0	0	0	0	0	
			C	V	0	0	0	0	0	
Q6	KTA1504Y	RX MODE	B	V	6.98	6.98	6.98	6.98	6.98	
			E	V	7.62	7.62	7.62	7.62	7.62	
			C	V	2.63	2.63	2.63	2.63	2.63	
Q21	KTC3880Y	RX MODE	B	V	3	3	3	3	3	
			E	V	2.4	2.4	2.4	2.4	2.4	
			C	V	7.78	7.78	7.78	7.78	7.78	



LOCATION	VALUE	SWITCH CONDITION		UNIT	CW	FM	AM	USB	LSB
Q36	KTC3880Y	RX/TX MODE	B	V	0.6	0.6	0.6	0.6	0.6
			E	V	0	0	0	0	0
			C	V	4.3	4.3	4.3	4.3	4.3
Q37	KTC3880Y	RX/TX MODE	B	V	2.8	2.8	2.8	2.8	2.8
			E	V	2.1	2.1	2.1	2.1	2.1
			C	V	7.1	7.1	7.1	7.1	7.1
Q38	KTC3880Y	RX/TX MODE	B	V	2.8	2.8	2.8	2.8	2.8
			E	V	2.1	2.1	2.1	2.1	2.1
			C	V	7.6	7.6	7.6	7.6	7.6
Q5	KTK211Y	NB/ANL SW. OFF	G	V	0	0	0	0	0
			D	V	0.814	0.813	0.813	0.813	0.813
			S	V	6.79	6.79	6.79	6.79	6.79
		NB/ANL SW. ON	G	mV	-15.3	-15.3	-15.2	-15.2	-15.7
			D	V	0.801	0.801	0.801	0.801	0.801
			S	V	6.8	6.8	6.8	6.8	6.8
Q4	KTC3880Y	NB/ANL SW. OFF	B	mV	174.8	173.5	156	153	152
			E	V	0	0	0	0	0
			C	mV	156.8	158	159.5	160	161
		NB/ANL SW. ON	B	V	0.721	0.721	0.721	0.721	0.721
			E	V	0	0	0	0	0
			C	mV	6.83	6.83	6.83	6.83	6.83
Q3	KTC3880Y	NB/ANL SW. OFF	B	V	0.274	0.243	0.228	0.217	0.207
			E	V	0	0	0	0	0
			C	V	0.21	0.217	0.229	0.244	0.253
		NB/ANL SW. ON	B	V	0.72	0.72	0.72	0.72	0.72
			E	V	0	0	0	0	0
			C	V	4.6	4.6	4.6	4.6	4.6
Q18	KTC3880Y	RX MODE	B	mV	72	78.2	72	73	73
			E	V	0	0	0	0	0
			C	V	0	0	0	0	0
Q11	KTK211Y	RX MODE	G	V	0	0	0	0	0
			D	V	1.2	1.2	1.2	1.2	1.2
			S	V	7.4	7.4	7.4	7.4	7.4
Q19	KTC3880Y	RF GAIN SW. MAX.-47dBm	B	V	2.15	2.15	2.15	2.15	2.15
			E	V	1.46	1.46	1.46	1.46	1.46
			C	V	6.83	6.83	6.83	6.83	6.83
		RF GAIN SW. MIN.-47dBm	B	V	2.2	2.2	2.2	2.2	2.2
			E	V	3	3	3	3	3
			C	V	6.9	6.9	6.9	6.9	6.9
Q22	KTC3880Y	RX MODE	B	V	0.746	0.746	0.746	0.746	0.746
			E	mV	165.8	165.8	165.8	165.8	165.8
			C	V	7.63	7.63	7.63	7.63	7.63
Q23	KTC3880Y	RX MODE	B	V	2.42	2.42	2.42	2.42	2.42
			E	V	1.73	1.73	1.73	1.73	1.73
			C	V	7	7	7	7	7
Q25	KTC3880Y	RX MODE	B	V	1.57	1.57	1.57	1.57	1.57
			E	V	0.914	0.914	0.914	0.914	0.914
			C	V	7.52	7.52	7.52	7.52	7.52
Q26	KTC3880Y	RX MODE	B	V	0.715	0.715	0.715	0.715	0.715
			E	V	0	0	0	0	0
			C	V	3.64	3.64	3.64	3.64	3.64



LOCATION	VALUE	SWITCH CONDITION		UNIT	CW	FM	AM	USB	LSB
Q27	KTC3880Y	RX MODE	B	V	3.62	3.62	3.62	3.62	3.62
			E	V	2.9	2.9	2.9	2.9	2.9
			C	V	7.18	7.18	7.18	7.18	7.18
Q28	KTC3880Y	RX MODE	B	V	2.9	2.9	2.9	2.9	2.9
			E	V	2.1	2.1	2.1	2.1	2.1
			C	V	6.7	6.7	6.7	6.7	6.7
Q29	C111	RX MODE	B	mV	50	.435V	7.8V	-10.5	-10.2
			E	V	0	0	0	0	0
			C	V	4.41	1.05	3.3mV	4.4	4.4
Q31	KTA1504	RX MODE	B	V	1.33	-0.65	-1.76	1.32	1.32
			E	V	1.35	^-140mV	^-1.2V	1.35	1.35
			C	V	1.35	^-144mV	^-1.2V	1.35	1.35
Q1	C3875Y	RX MODE SQ. AT MIN.	B	mV	2.4	2.4	2.4	2.4	2.4
			E	V	0	0	0	0	0
			C	V	0	0	0	0	0
Q2	C3875Y	RX MODE SQ. AT MAX.	B	mV	4.5	4.5	4.5	4.5	4.5
			E	V	0	0	0	0	0
			C	mV	34.6	37.2	74.9	67.7	66.8
Q46	A101	TX MODE SWR ON / ANTENNA CONNECTED	B	V	5.9	5.9	5.9	5.9	5.9
			E	V	6.3	6.3	6.3	0	0
			C	V	0	0	0	0	0
		TX MODE SWR ON / ANTENNA DISCONNECTED	B	V	0	0	0	0	0
			E	V	1.5	1.5	1.5	0	0
			C	V	0	0	0	0	0
Q8	C3880Y	TX MODE SWR ON / ANTENNA CONNECTED	B	V	0.2	0.2	0.2	0	0
			E	V	0	0	0	0	0
			C	V	5.9	5.9	5.9	0	0
		TX MODE SWR ON / ANTENNA DISCONNECTED	B	V	0.5	0.5	0.5	0	0
			E	V	0	0	0	0	0
			C	V	0	0	0	0	0